



US010574384B2

(12) **United States Patent**
Morrow et al.

(10) **Patent No.:** **US 10,574,384 B2**
(45) **Date of Patent:** **Feb. 25, 2020**

(54) **DUAL-GRIP PORTABLE COUNTERMEASURE DEVICE AGAINST UNMANNED SYSTEMS**

(58) **Field of Classification Search**
CPC H04K 3/92; H04K 3/65; H04K 3/825;
H04K 3/41; H04K 2203/24;
(Continued)

(71) Applicant: **Dedrone Holdings, Inc.**, San Francisco, CA (US)

(56) **References Cited**

(72) Inventors: **Alexander Morrow**, Gahanna, OH (US); **Daniel E. Stamm**, Columbus, OH (US); **Raphael J. Welsh**, Powell, OH (US); **Daniel G. Loesch**, Columbus, OH (US); **Zachary Schmid**, Columbus, OH (US)

U.S. PATENT DOCUMENTS

4,584,578 A 4/1986 Brauns et al.
5,001,771 A 3/1991 New
(Continued)

(73) Assignee: **Dedrone Holdings, Inc.**, San Francisco, CA (US)

FOREIGN PATENT DOCUMENTS

WO WO 2007/012147 A1 2/2007
WO WO 2007/012148 A1 2/2007
WO WO 2017/053693 3/2017

(*) Notice: Subject to any disclaimer, the term of this patent is extended or adjusted under 35 U.S.C. 154(b) by 0 days.

OTHER PUBLICATIONS

WiFi Sniper Rifle; Jun. 21, 2011; <https://tinyurl.com/wifisniper rifle>.
(Continued)

(21) Appl. No.: **16/274,325**

Primary Examiner — Ayodeji O Ayotunde
(74) *Attorney, Agent, or Firm* — Morris, Manning & Martin, LLP; Daniel E. Sineway, Esq.; Adam J. Thompson, Esq.

(22) Filed: **Feb. 13, 2019**

(65) **Prior Publication Data**
US 2019/0173605 A1 Jun. 6, 2019

Related U.S. Application Data

(63) Continuation-in-part of application No. 16/005,905, filed on Jun. 12, 2018, which is a continuation of
(Continued)

(51) **Int. Cl.**
H04K 3/00 (2006.01)
G08B 6/00 (2006.01)
(Continued)

(52) **U.S. Cl.**
CPC **H04K 3/92** (2013.01); **G08B 6/00** (2013.01); **G08B 7/06** (2013.01); **H01Q 21/22** (2013.01);
(Continued)

(57) **ABSTRACT**

A portable countermeasure device is provided comprising one or more directional antennae, one or more disruption components and at least one activator. The portable countermeasure device further comprises a body having a dual-grip configuration, with the directional antennae affixed to a removable plate on a front portion of the body. The one or more disruption components may be internally mounted within the device body. The dual-grip configuration allows an operator to use his body to steady and support the device while maintaining the antenna on target. The second grip is positioned adjacent the first grip, with the first grip angled toward the rear of the device and the second grip angled toward the front of the device. The portable countermeasure device is aimed at a specific drone, the activator is engaged,

(Continued)

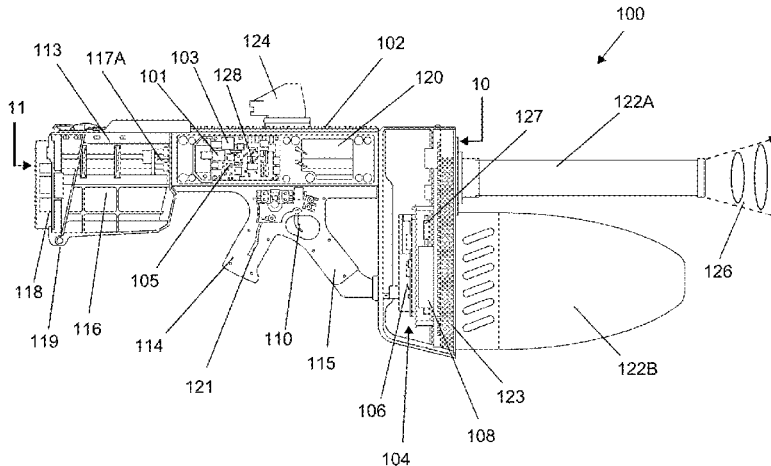

and disruptive signals are directed toward the drone, disrupting the control, navigation, and other signals to and from the drone.

22 Claims, 38 Drawing Sheets

Related U.S. Application Data

application No. 15/596,842, filed on May 16, 2017, now Pat. No. 10,020,909, which is a continuation-in-part of application No. 15/274,021, filed on Sep. 23, 2016, now Pat. No. 10,103,835.

(60) Provisional application No. 62/222,475, filed on Sep. 23, 2015.

(51) **Int. Cl.**
G08B 7/06 (2006.01)
H01Q 21/22 (2006.01)

(52) **U.S. Cl.**
 CPC **H04K 3/41** (2013.01); **H04K 3/65** (2013.01); **H04K 3/825** (2013.01); **H04K 3/42** (2013.01); **H04K 2203/22** (2013.01); **H04K 2203/24** (2013.01); **H04K 2203/32** (2013.01)

(58) **Field of Classification Search**
 CPC .. H04K 2203/32; H04K 2203/22; H04K 3/42; G08B 6/00; G08B 7/06; H01Q 21/22
 USPC 455/1
 See application file for complete search history.

(56) **References Cited**

U.S. PATENT DOCUMENTS

5,287,110	A	2/1994	Tran
5,822,429	A	10/1998	Casabona et al.
5,896,105	A	4/1999	Murphy et al.
6,230,371	B1 *	5/2001	Chu F41C 33/001 24/17 B
6,396,432	B1	5/2002	Riemschneider et al.
6,480,144	B1	11/2002	Miller
6,977,598	B2	12/2005	Longbottom
7,050,755	B2	5/2006	Kline
7,099,369	B2	8/2006	Karlsson
7,318,368	B2	1/2008	Ham et al.
7,423,575	B2	9/2008	Duff et al.
7,489,264	B2	2/2009	Ferm et al.
7,554,481	B2	6/2009	Cohen et al.
7,574,168	B2	8/2009	Twitchell et al.
7,697,885	B2	4/2010	Stoddard
7,698,846	B2	4/2010	Do Amarante
7,783,246	B2	8/2010	Twitchell, Jr. et al.
7,784,390	B1	8/2010	Lowell et al.
8,001,901	B2	8/2011	Bass
8,135,661	B2	3/2012	Olsson
8,145,119	B2	3/2012	Cornwell
8,170,467	B2	5/2012	Soddard
8,203,109	B2	6/2012	Taylor et al.
8,269,957	B2	9/2012	Saban et al.
8,301,075	B2	10/2012	Sherman et al.
8,388,243	B1	3/2013	Smith
8,615,190	B2	12/2013	Lu
8,903,304	B2	12/2014	Coleman et al.

8,971,441	B2	3/2015	Dowla et al.
9,071,385	B2	6/2015	Delaveau et al.
9,207,049	B2	12/2015	Rovinsky
9,404,750	B2	8/2016	Rios
2003/0058112	A1	3/2003	Gleine
2003/0110675	A1	6/2003	Garrett et al.
2005/0011101	A1	1/2005	Gooder
2005/0041728	A1	2/2005	Karlsson
2006/0226950	A1 *	10/2006	Kanou G06F 21/10 340/5.61
2007/0063886	A1	3/2007	Brumley, II et al.
2008/0174469	A1	7/2008	Stark et al.
2009/0214205	A1	8/2009	Clark et al.
2009/0287363	A1	11/2009	Young
2011/0000389	A1	1/2011	Fullerton
2011/0176674	A1	7/2011	Romain
2013/0015260	A1	1/2013	Schulte
2013/0023201	A1	1/2013	Coleman et al.
2014/0145993	A1	5/2014	Nakayama
2014/0147116	A1	5/2014	Krupkin
2014/0266851	A1	9/2014	Fink et al.
2015/0229434	A1	8/2015	Shawn
2015/0350914	A1	12/2015	Baxley
2017/0250778	A1	8/2017	Stamm et al.

OTHER PUBLICATIONS

Hunter Scott Hack Rifle; Jan. 19, 2015; <https://www.hscott.net/hack-rifle>.

BlueSniper Rifle; Aug. 6, 2004; <https://tinyurl.com/bluesniperrifle>.

How to Build a BlueSniper Rifle; Mar. 8, 2005; <https://tinyurl.com/bluesniperrifle1>.

Sniping 2.4GHZ; Apr. 21, 2014; <https://tinyurl.com/sniping2-4ghz>.

“World’s First Fully Integrated Anti-UAV Defence System (AUDS) Now Features Quad Band RF Inhibitor and Optical Disruptor”; Sep. 8, 2015; <https://www.blighter.com/worlds-first-fully-integrated-anti-uav-defence-system-auds-now-features-quad-band-rf-inhibitor-and-optical-disruptor/>.

“AUDS—Anti-UAV Defence System”; May 11, 2019; https://www.youtube.com/watch?time_continue=66&v=P8aZ0zWX3SA.

3G Mobile Phone Jammer; accessed from <http://www.jammerfromchina.com>.

3W High Power Portable All Wireless Bug Camera; accessed from <http://www.jammerfromchina.com>.

Cell phone jammer Search by Functions; accessed from <http://www.jammerfromchina.com>.

L5 3G Mobile Phone Signal Jammer; accessed from <http://www.jammerfromchina.com>.

New Arrival All-in-one Handheld GPS 2G 3G 4G Mobile Phone; accessed from <http://www.jammerfromchina.com>.

PCS_3G_WiFi_GPS Signal Blocker; accessed from <http://www.jammerfromchina.com>.

Phone Jammer—Wholesale Jammer—DropShip From China; accessed from <http://www.jammerfromchina.com>.

Clear Sky jammers e-RAKE; accessed from <http://www.hypercable.fr>.

High Gain Directional Antennas for High Power Adjustable WiFi Phone Jammer; accessed from <http://www.alljammers.com>.

Directional RF Jammer for blocking cellular phone calls; accessed from <http://www.secintel.com>.

Drone jammer instruction set.

Fitriyani et al.; Yagi antenna design for signal phone jammer; 2012.

International Search Report for PCT Application No. PCT/US2018/032732 dated Aug. 8, 2018.

* cited by examiner

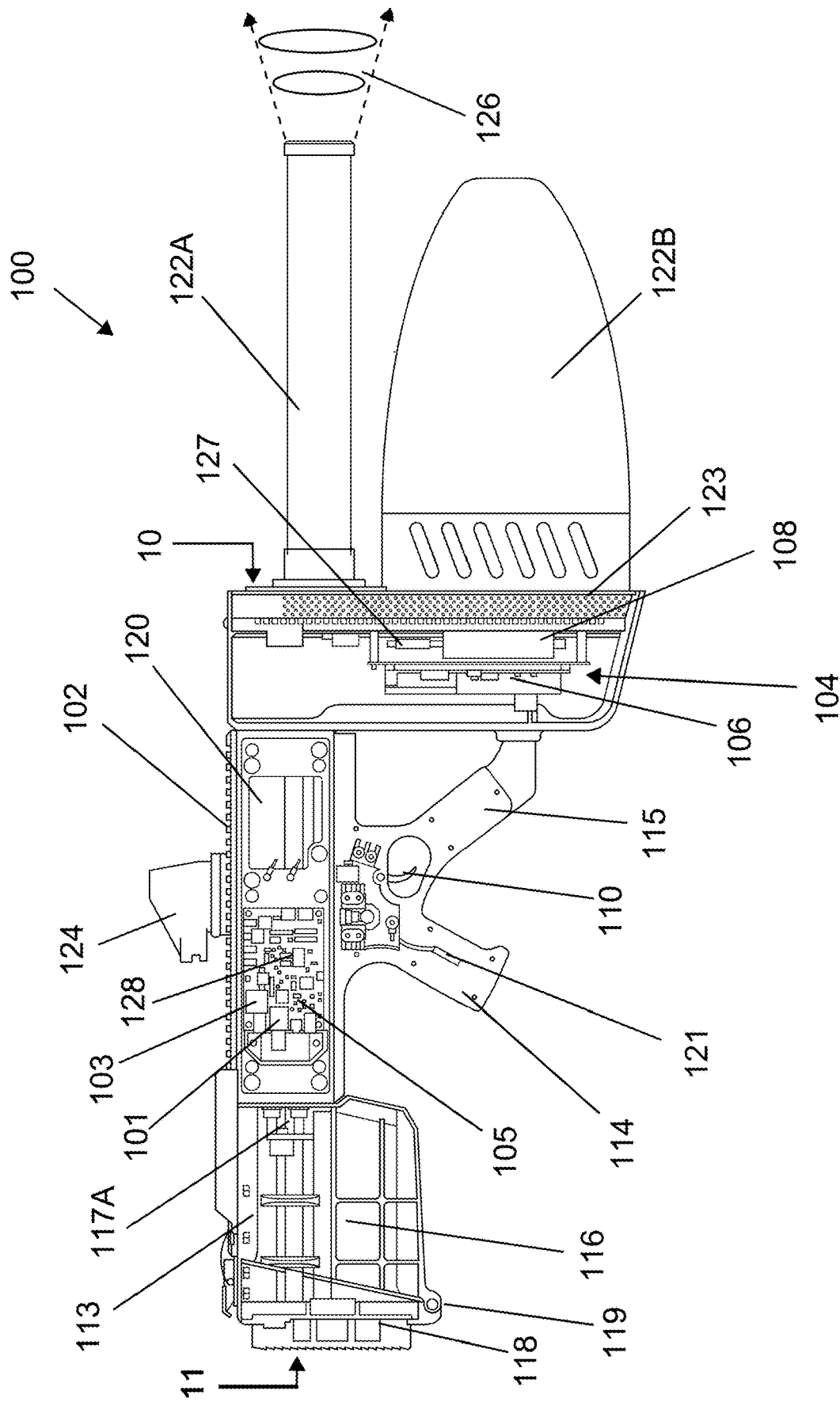

FIG. 1

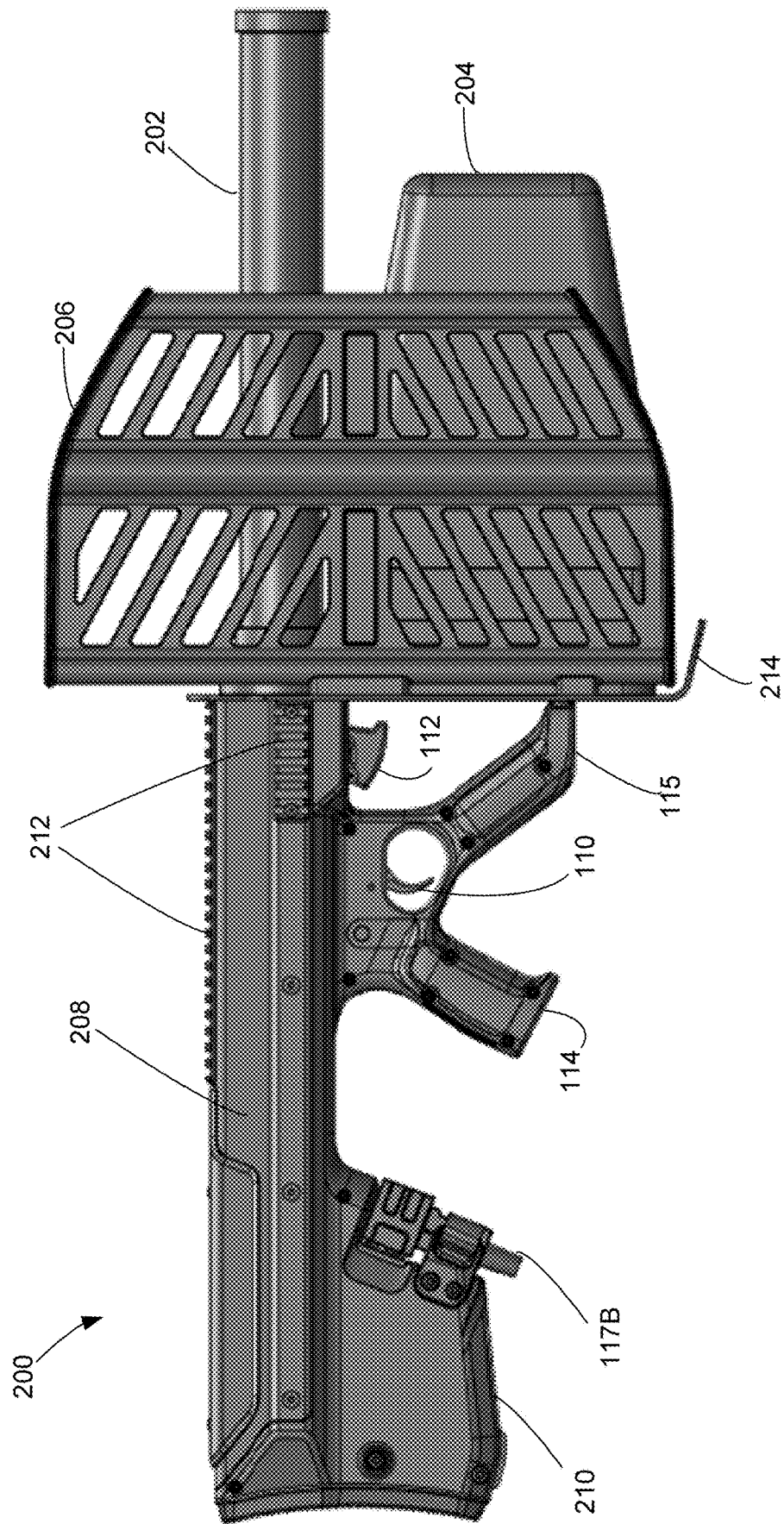

FIG. 2A

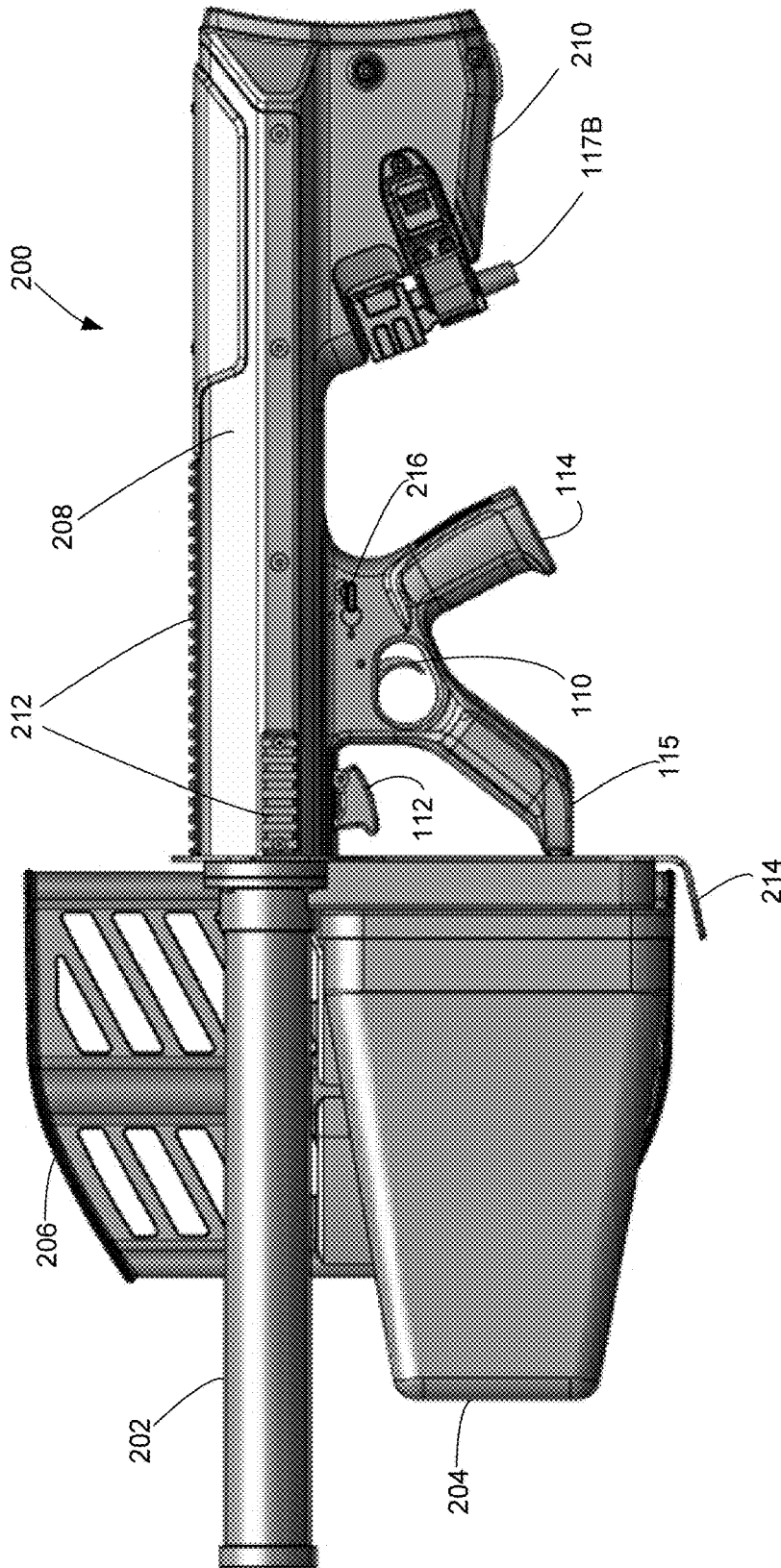

FIG. 2B

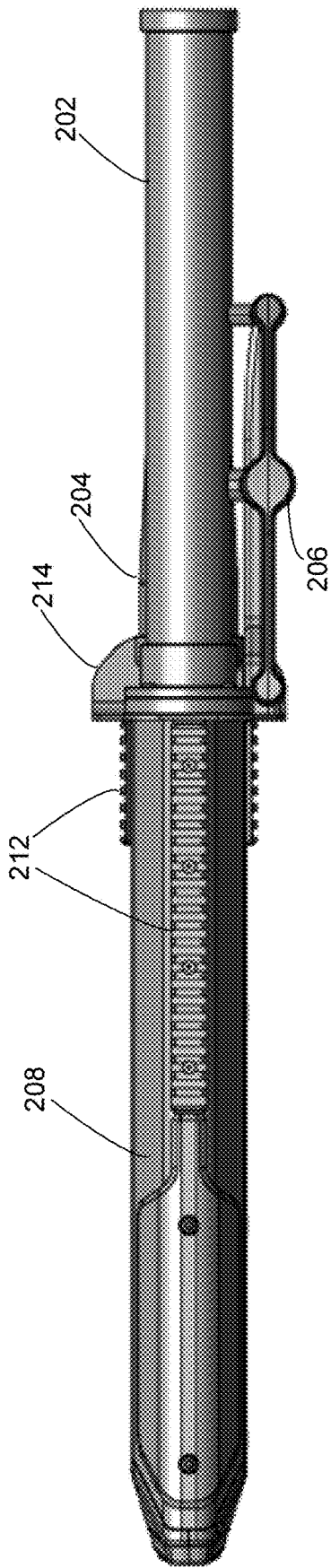

FIG. 2C

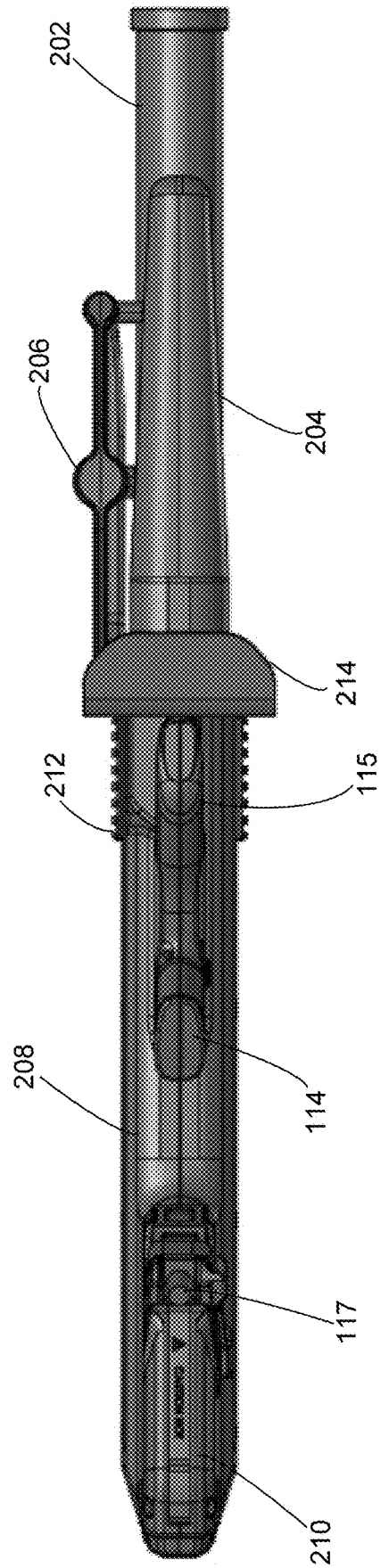

FIG. 2D

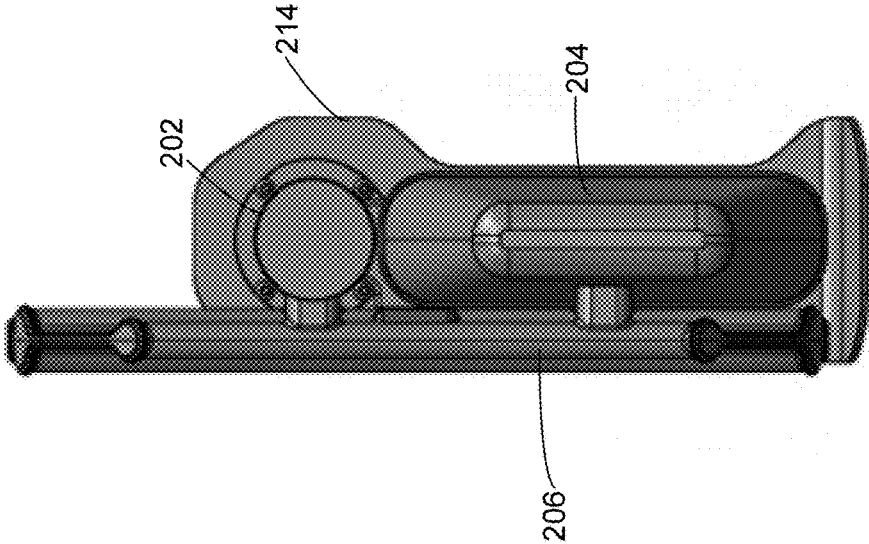

FIG. 2E

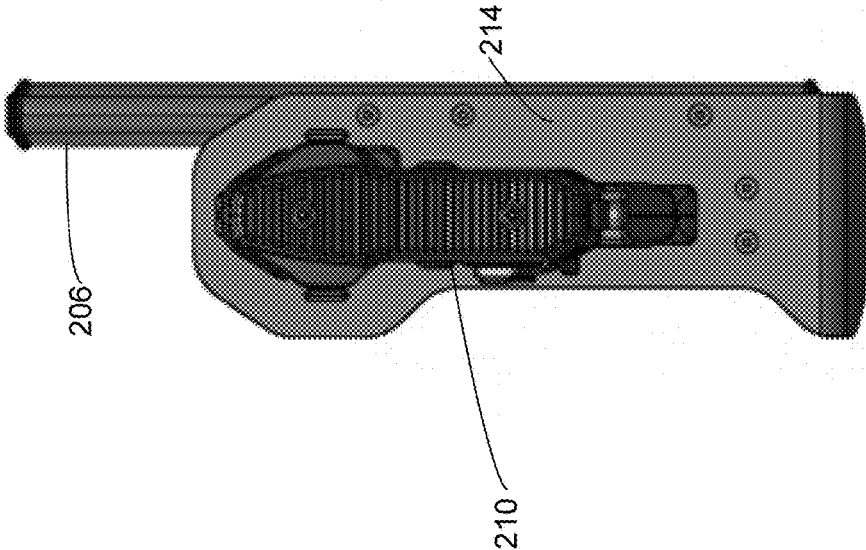

FIG. 2F

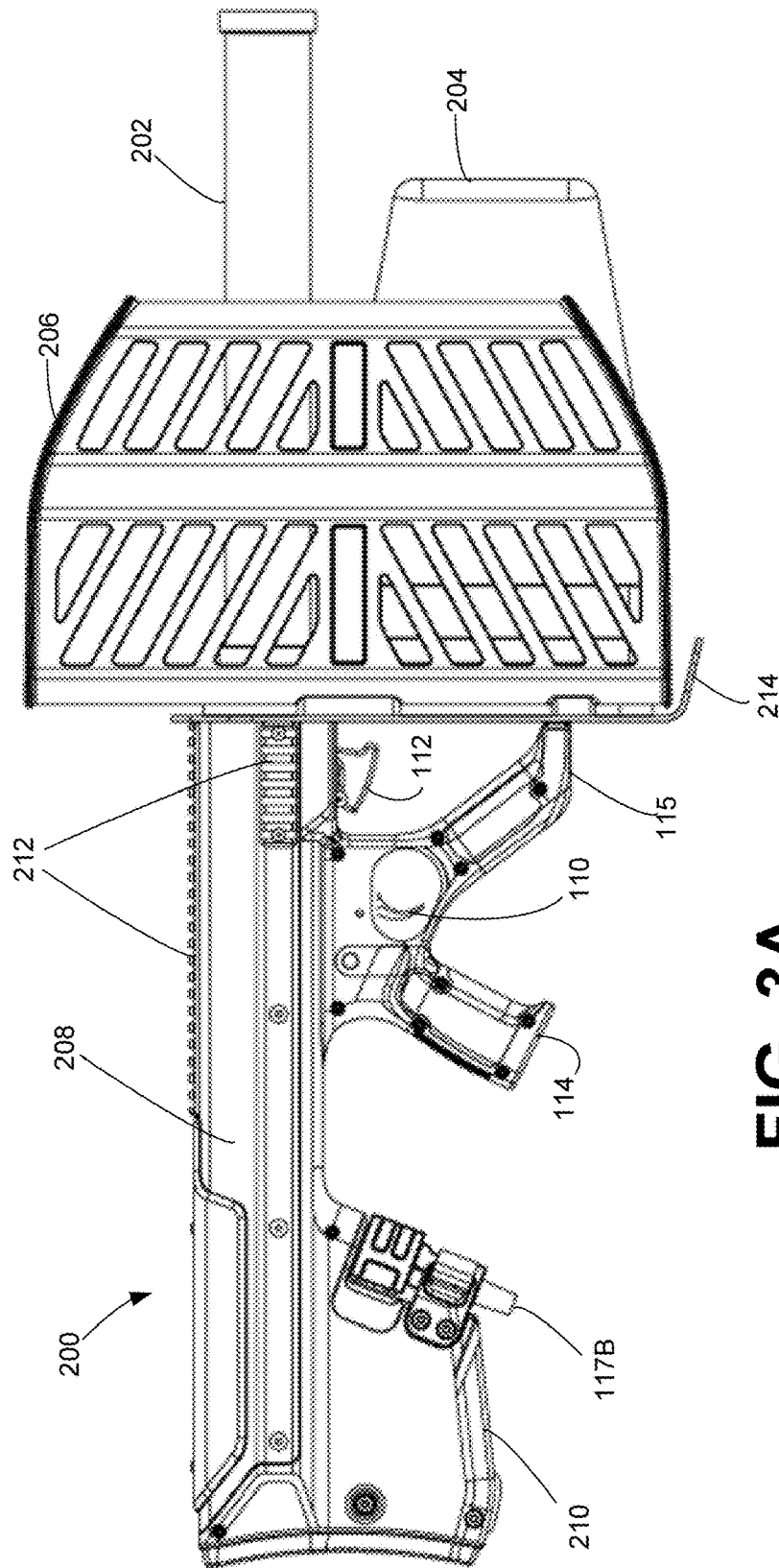

FIG. 3A

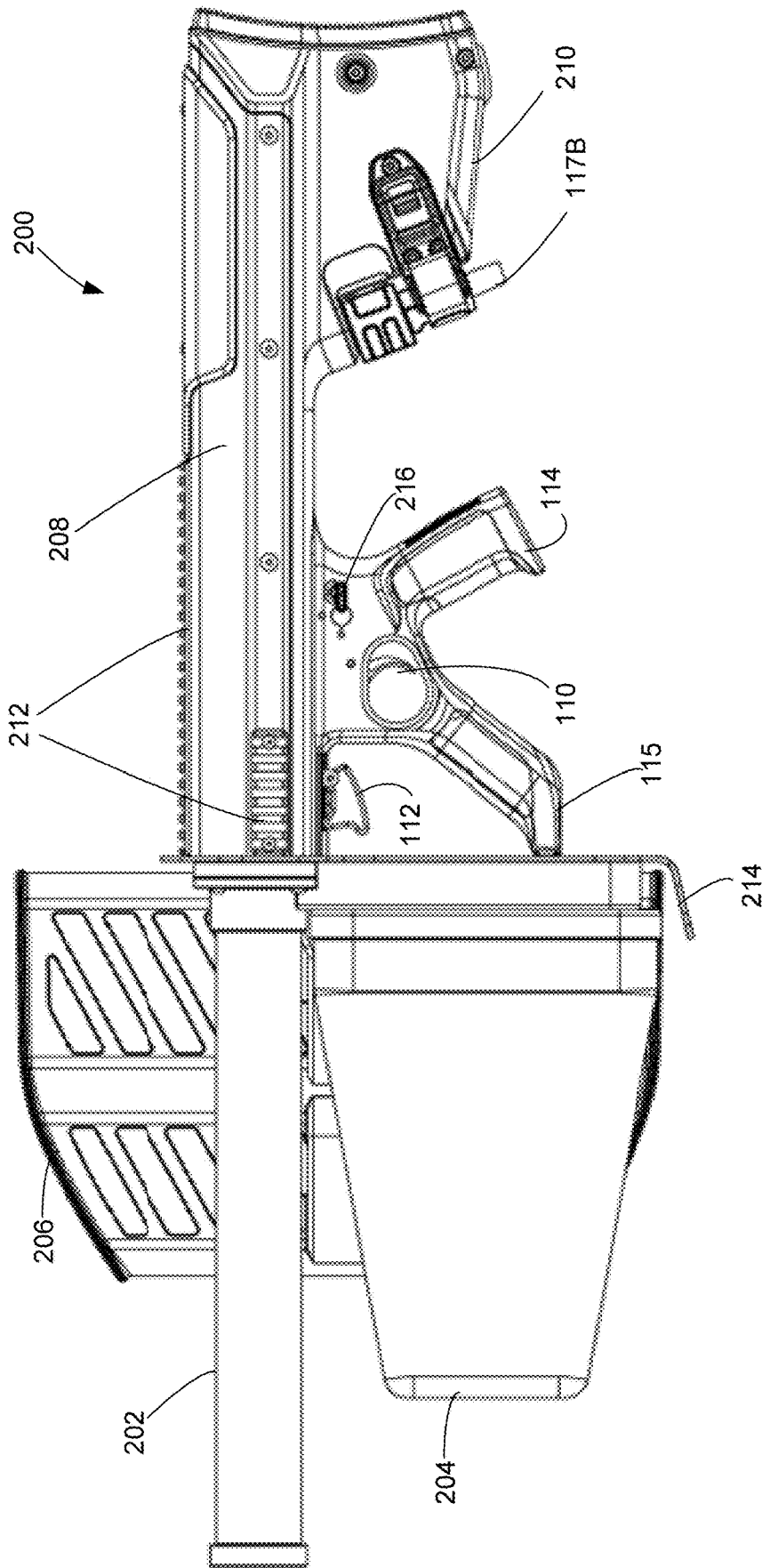

FIG. 3B

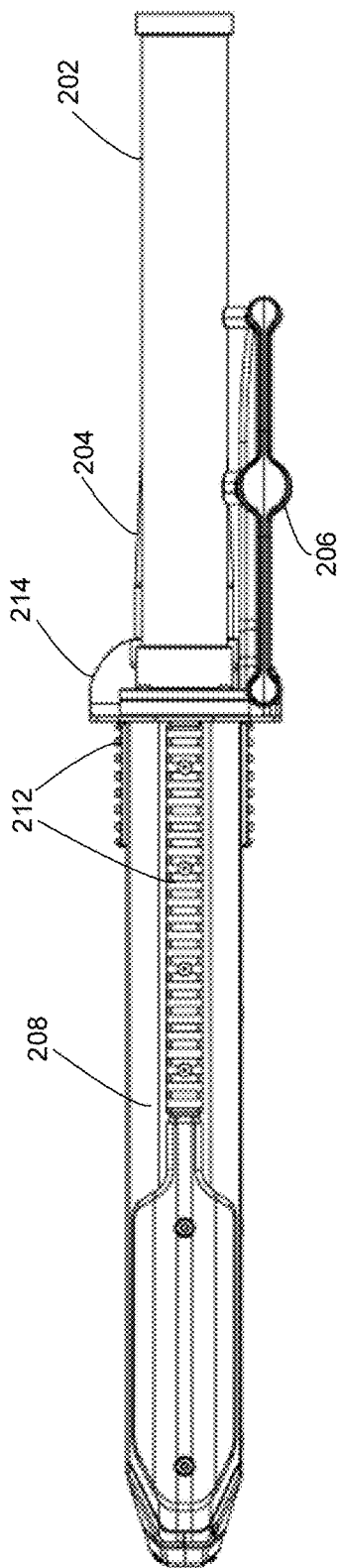

FIG. 3C

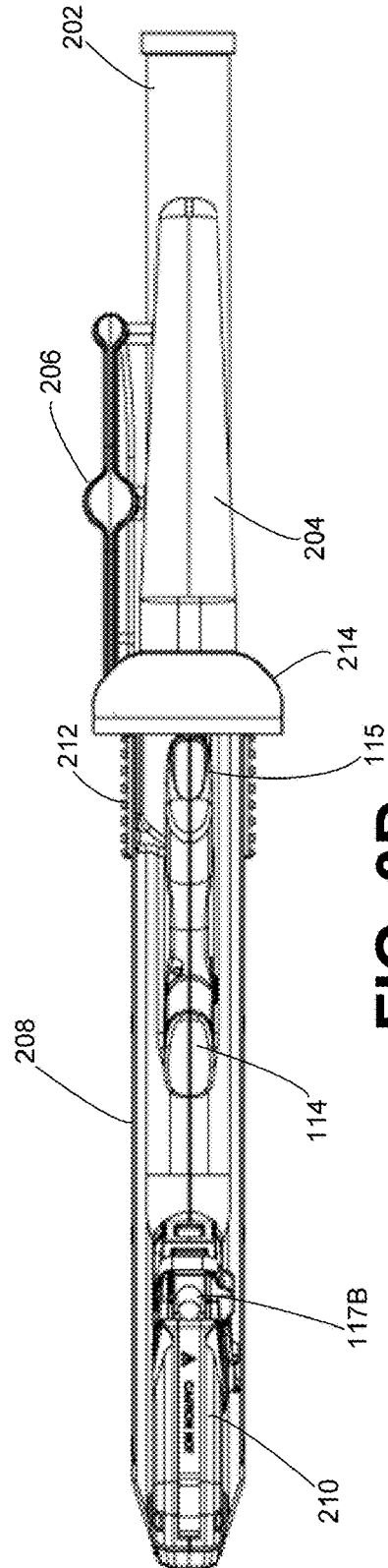

FIG. 3D

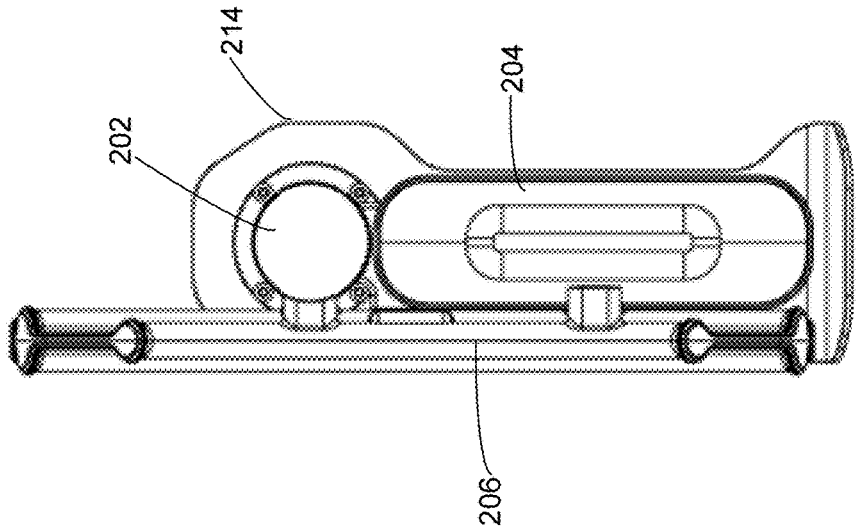

FIG. 3E

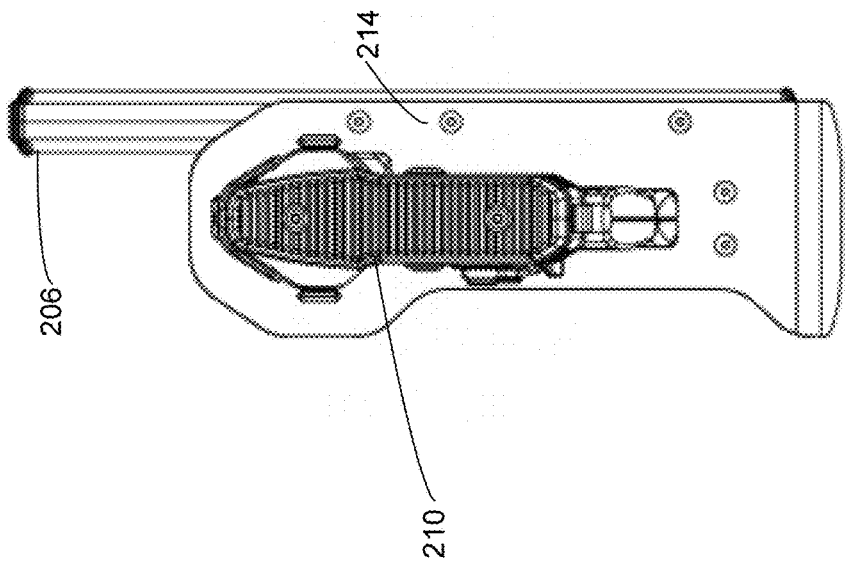

FIG. 3F

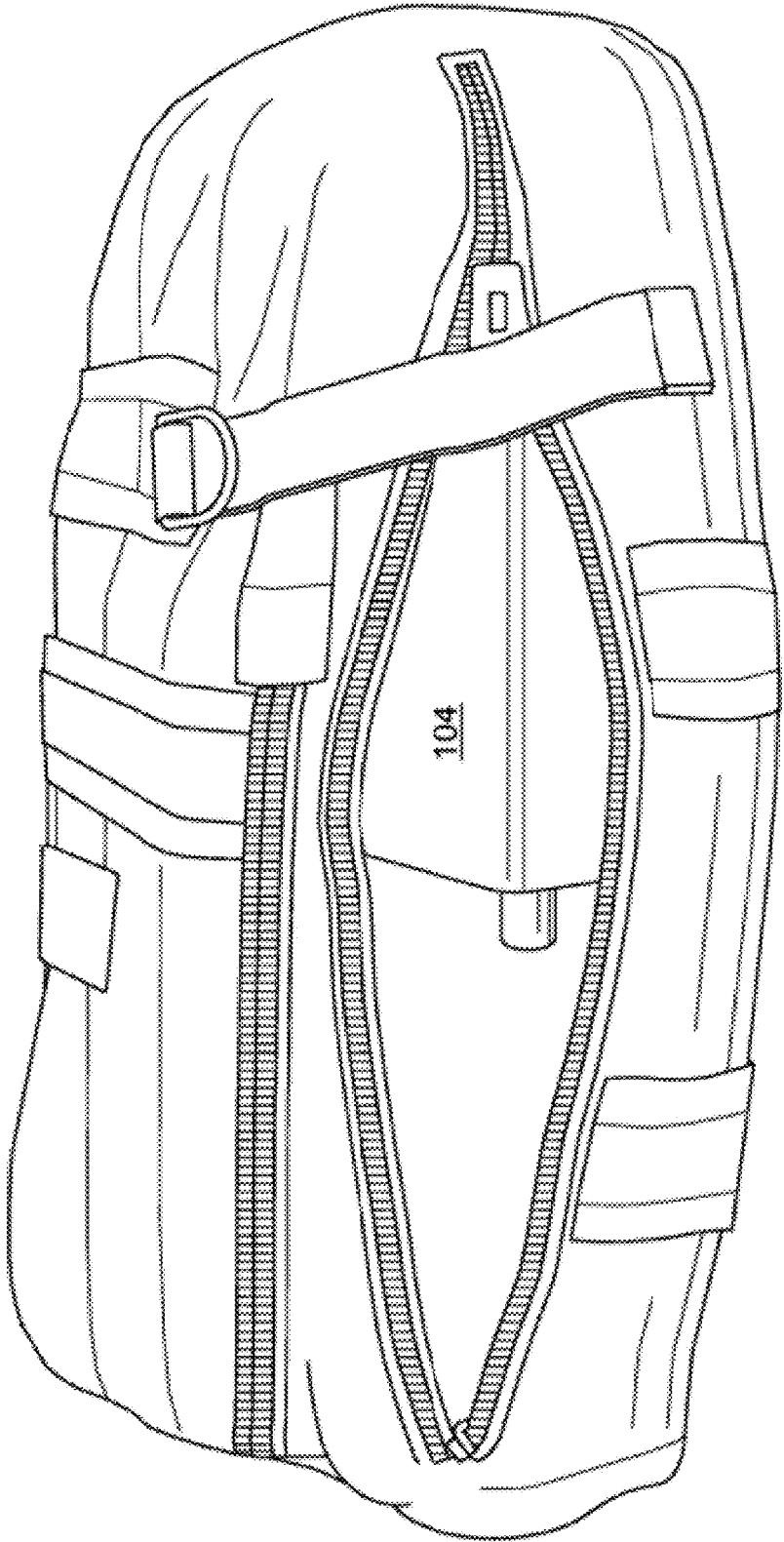

FIG. 4

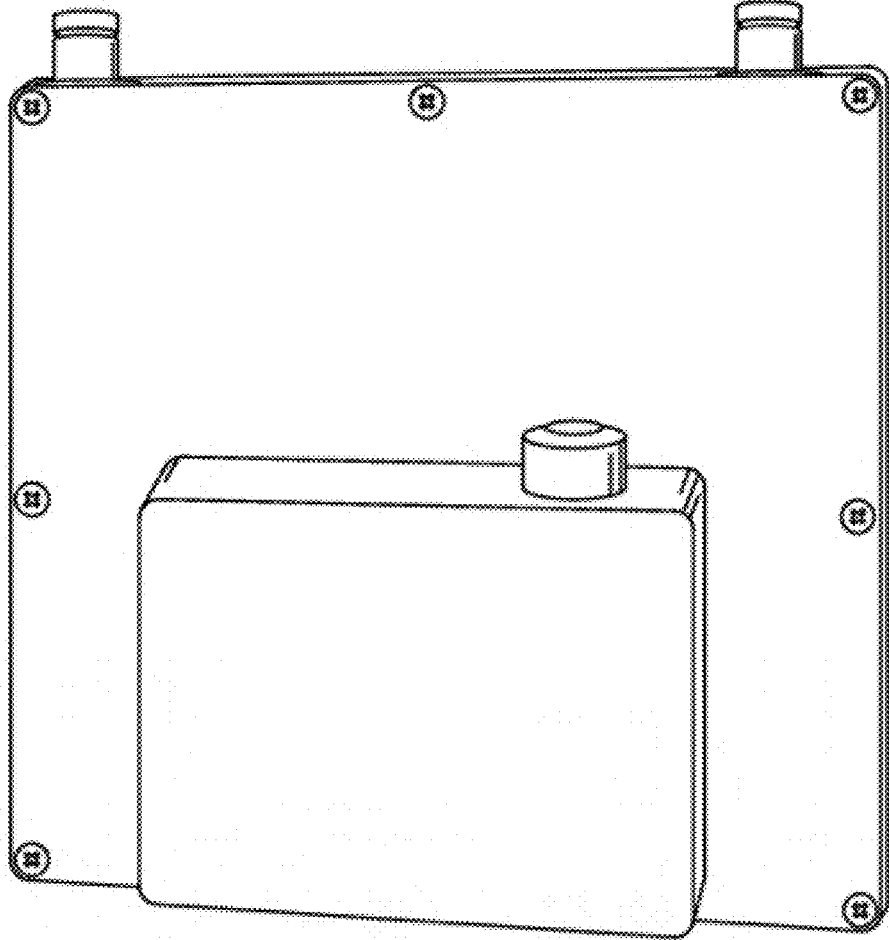

FIG. 5

104

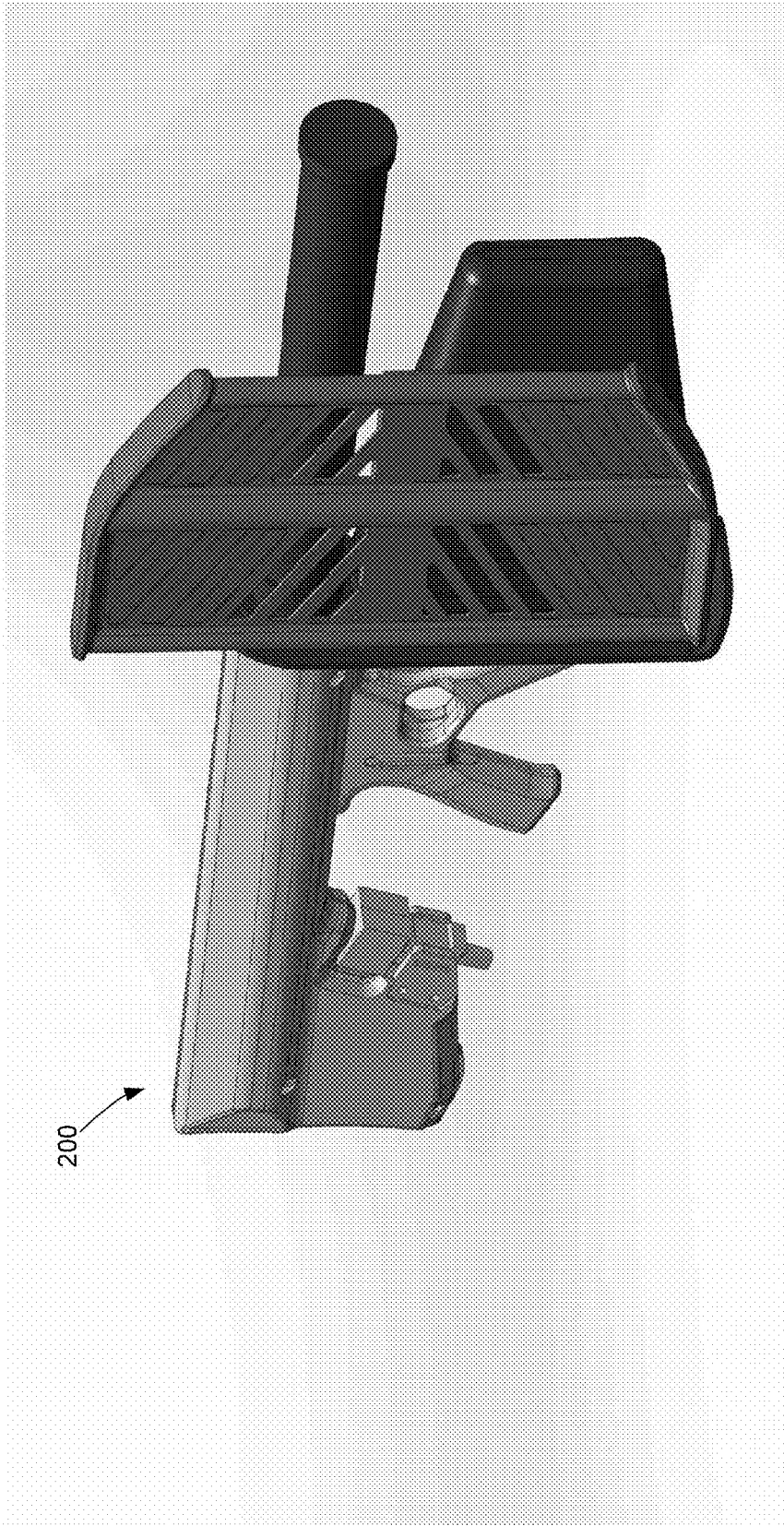

FIG. 6A

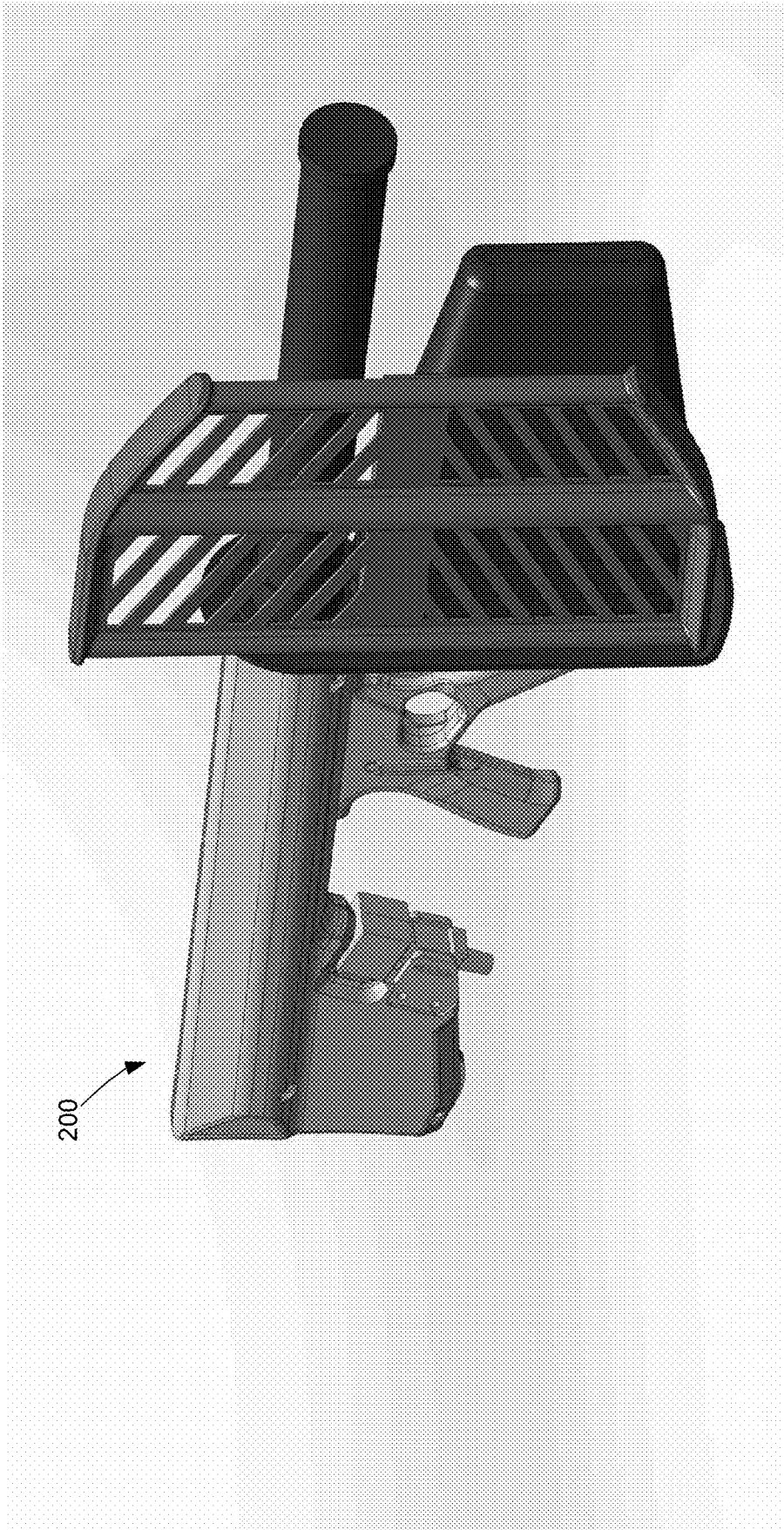

FIG. 6B

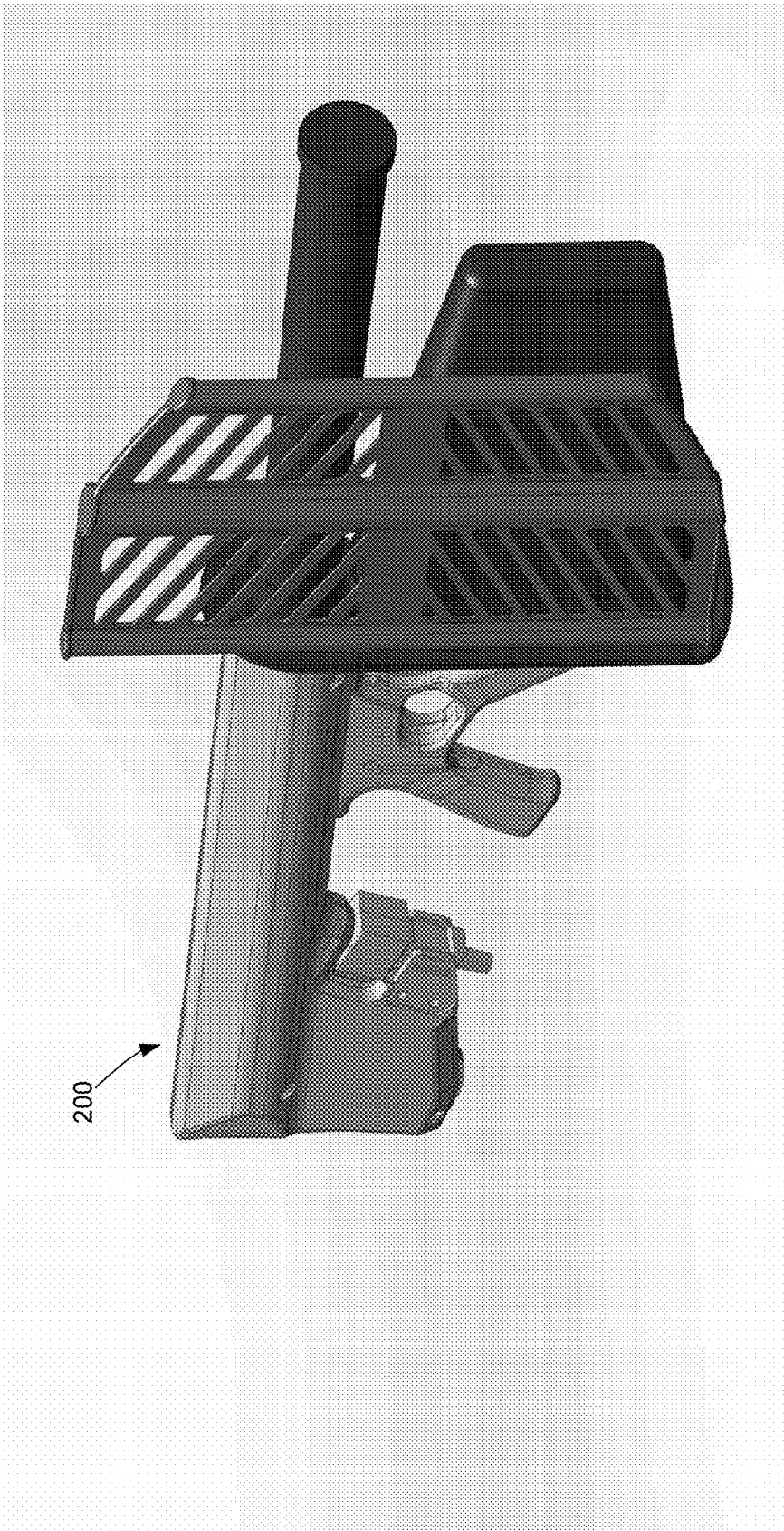

FIG. 6C

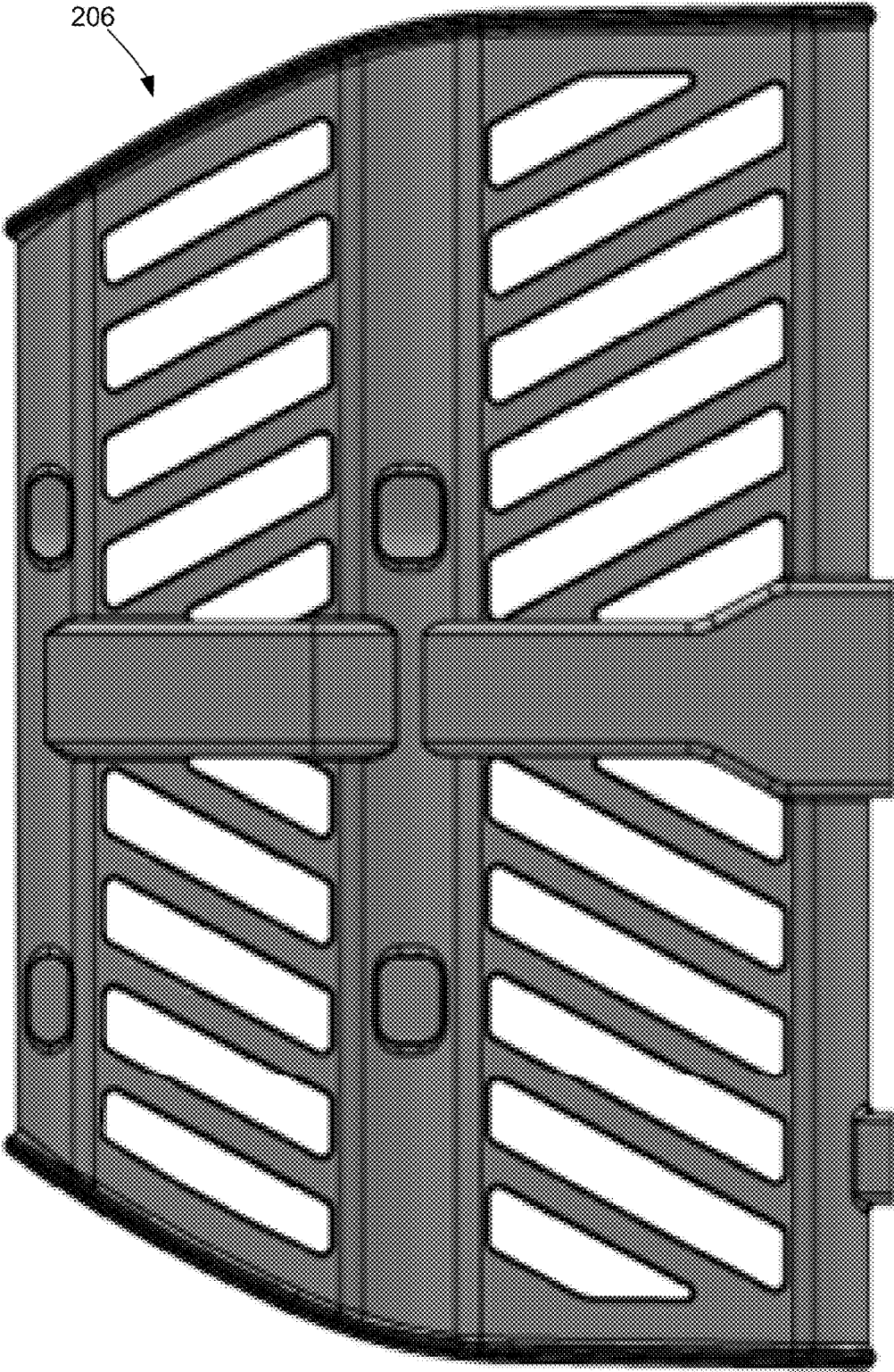

FIG. 7A

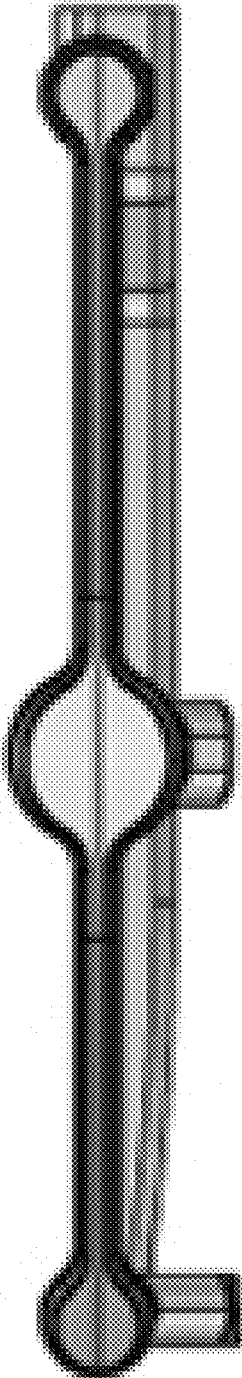

FIG. 7B

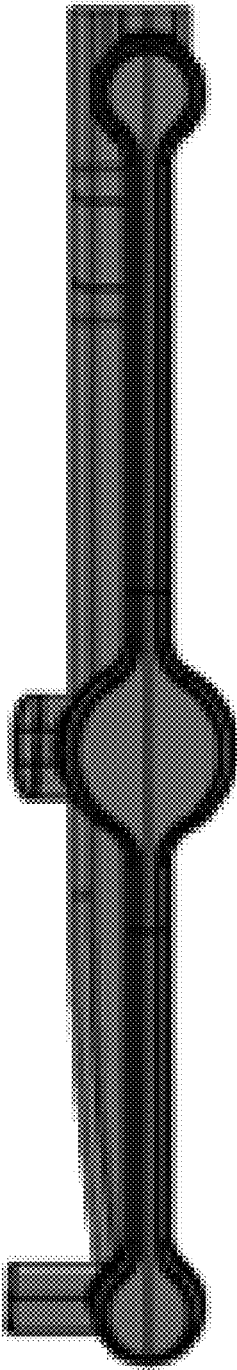

FIG. 7C

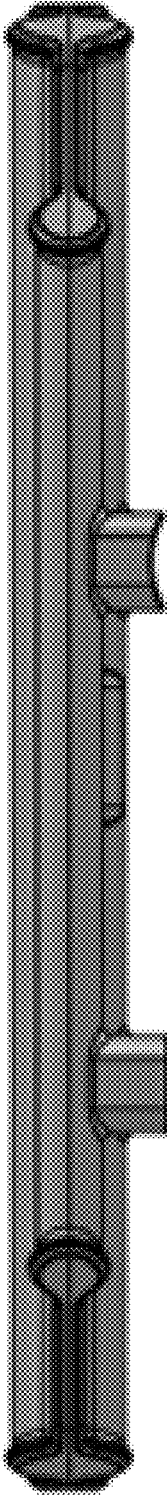

FIG. 7D

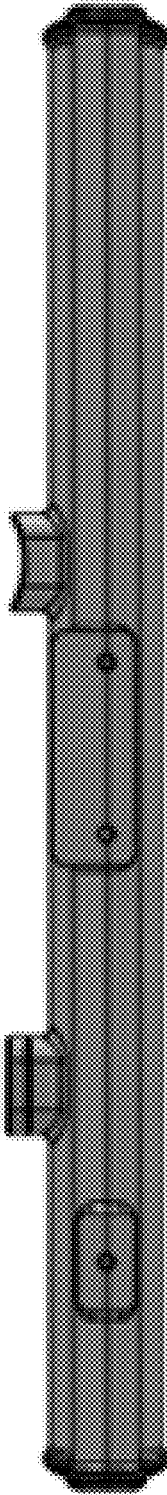

FIG. 7E

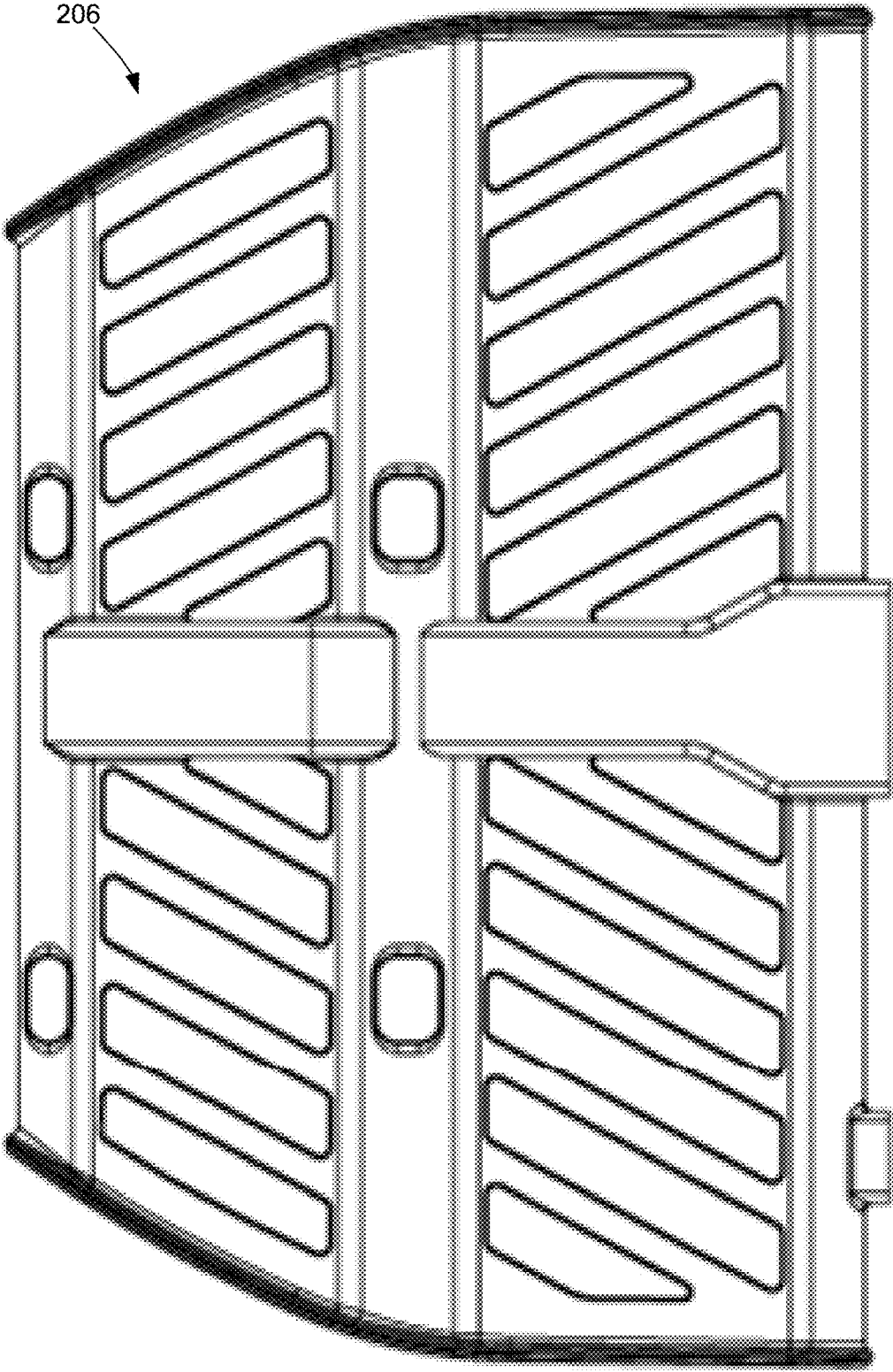

FIG. 8A

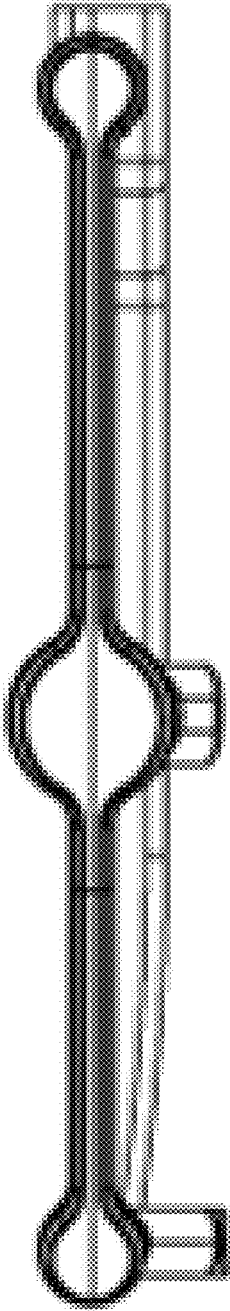

FIG. 8B

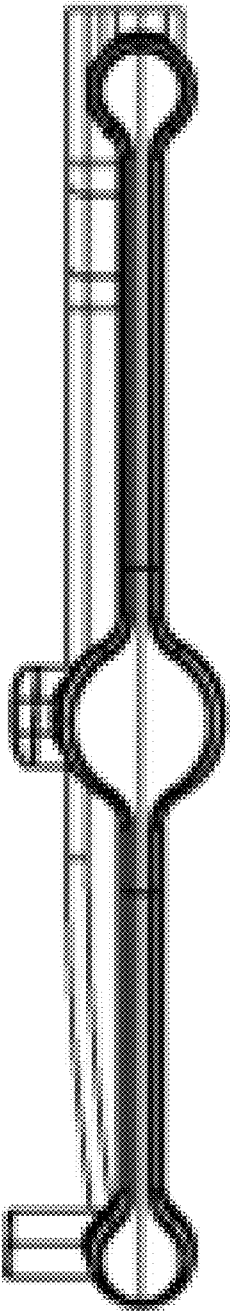

FIG. 8C

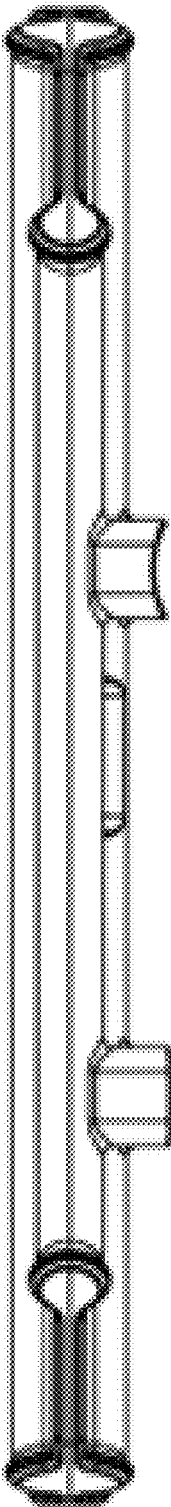

FIG. 8D

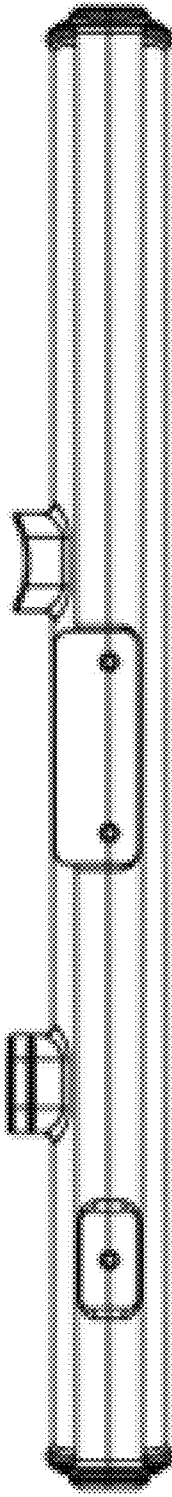

FIG. 8E

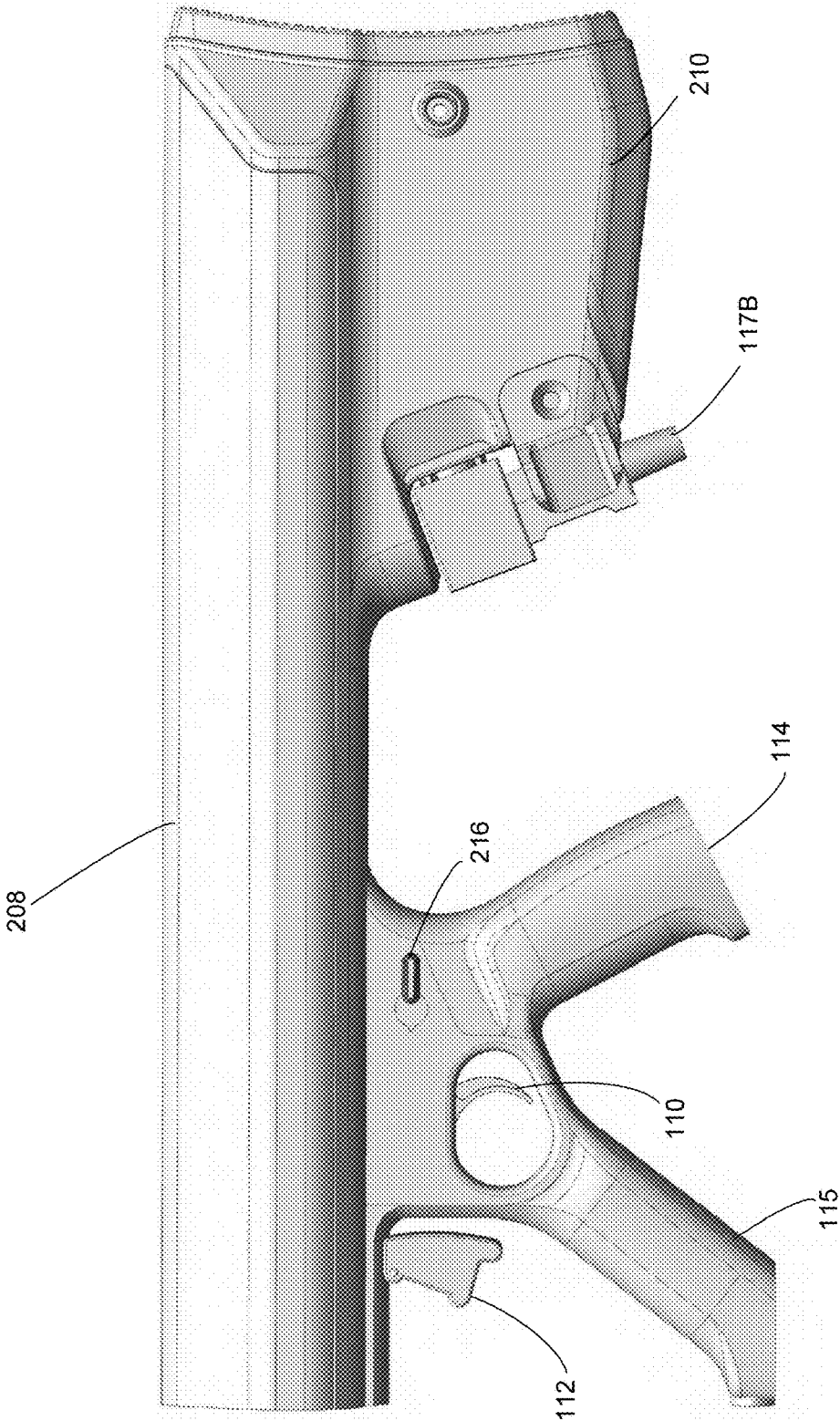

FIG. 9A

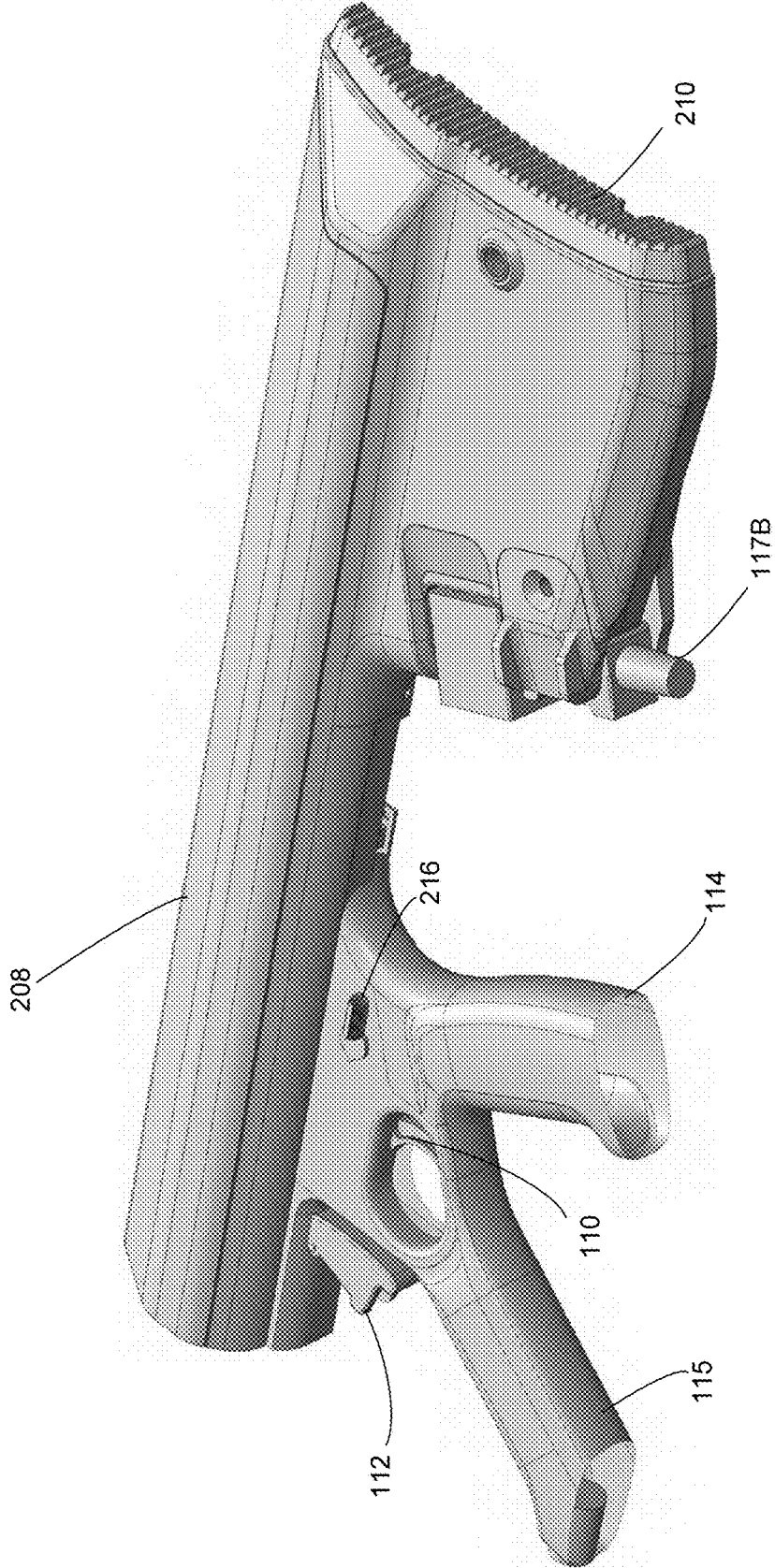
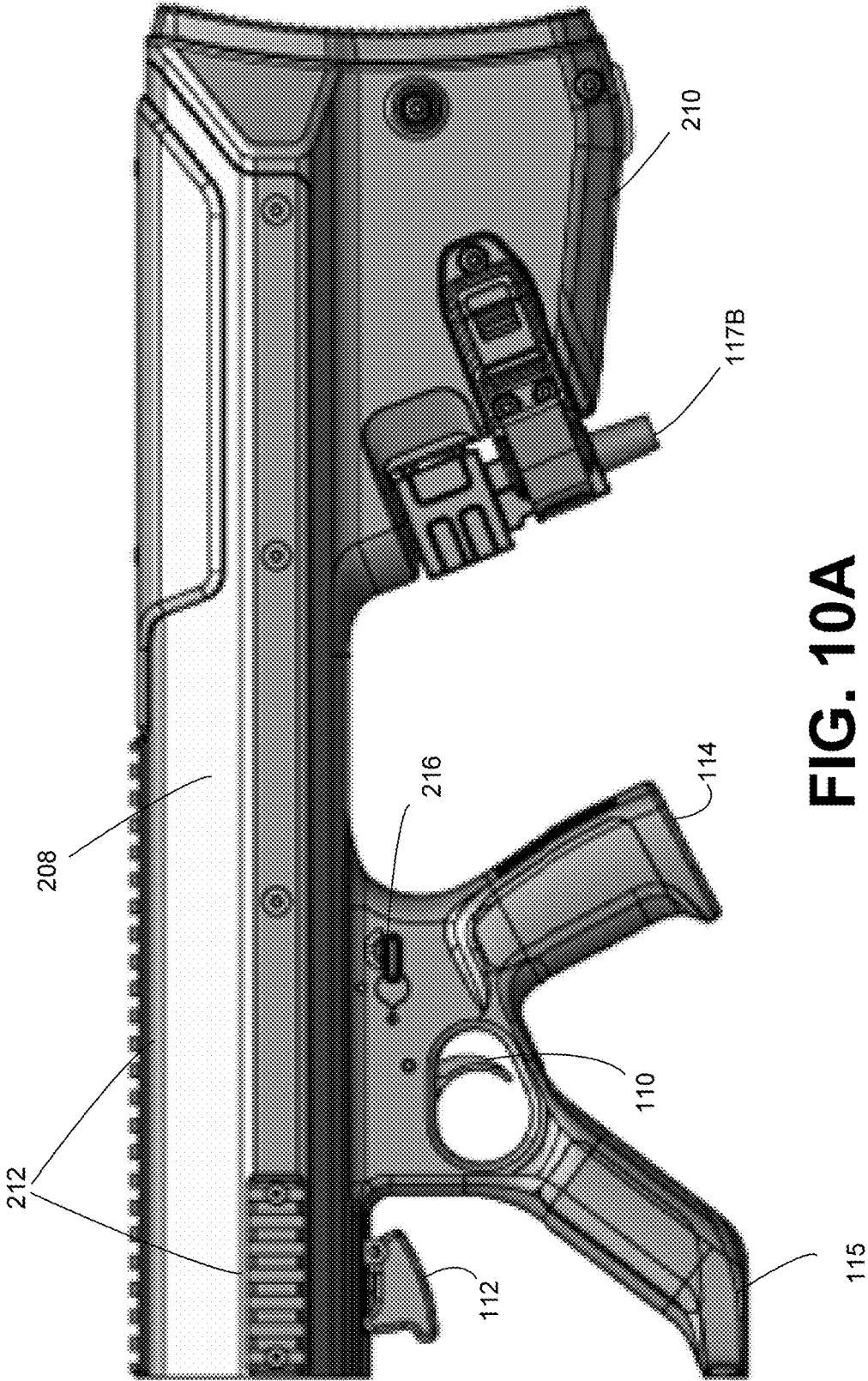

FIG. 9B



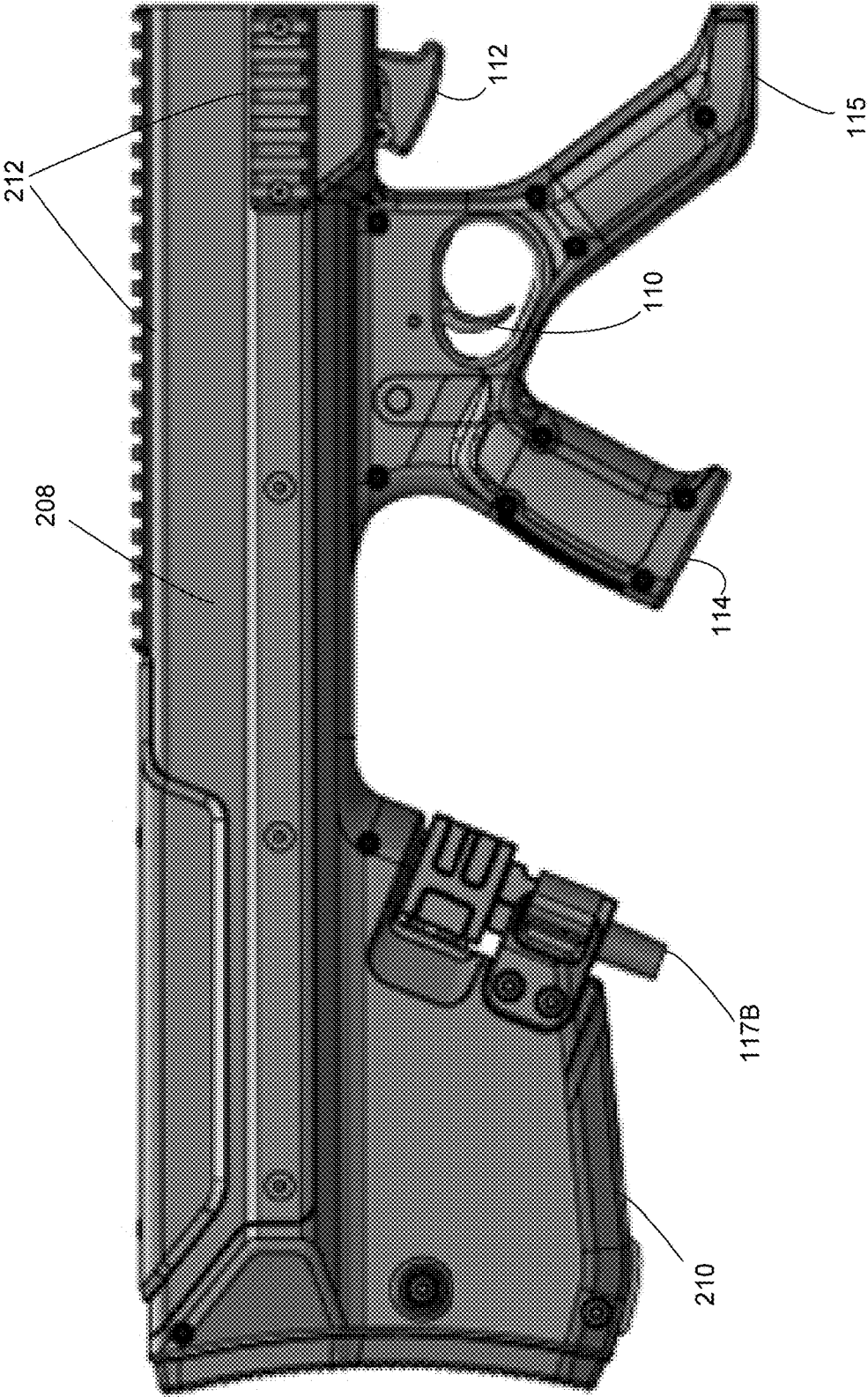

FIG. 10B

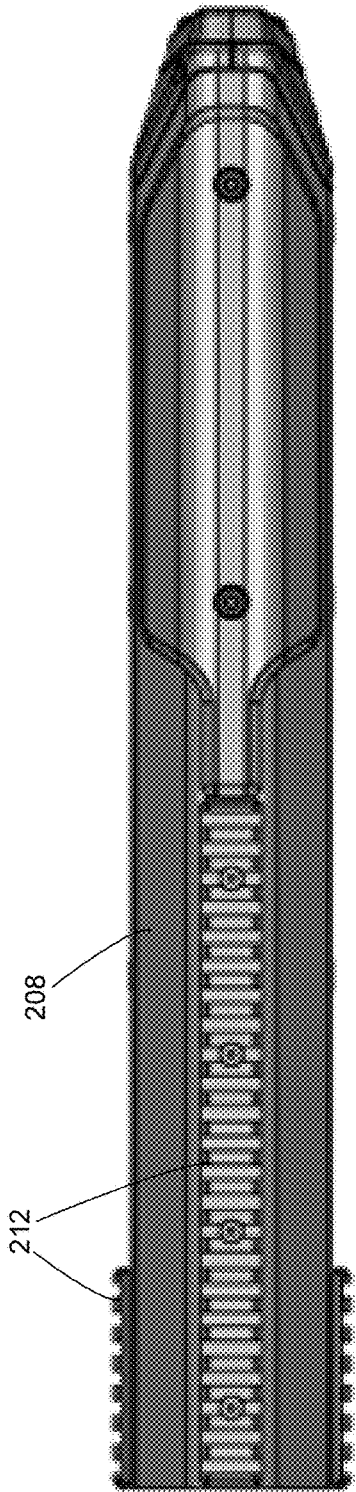

FIG. 10C

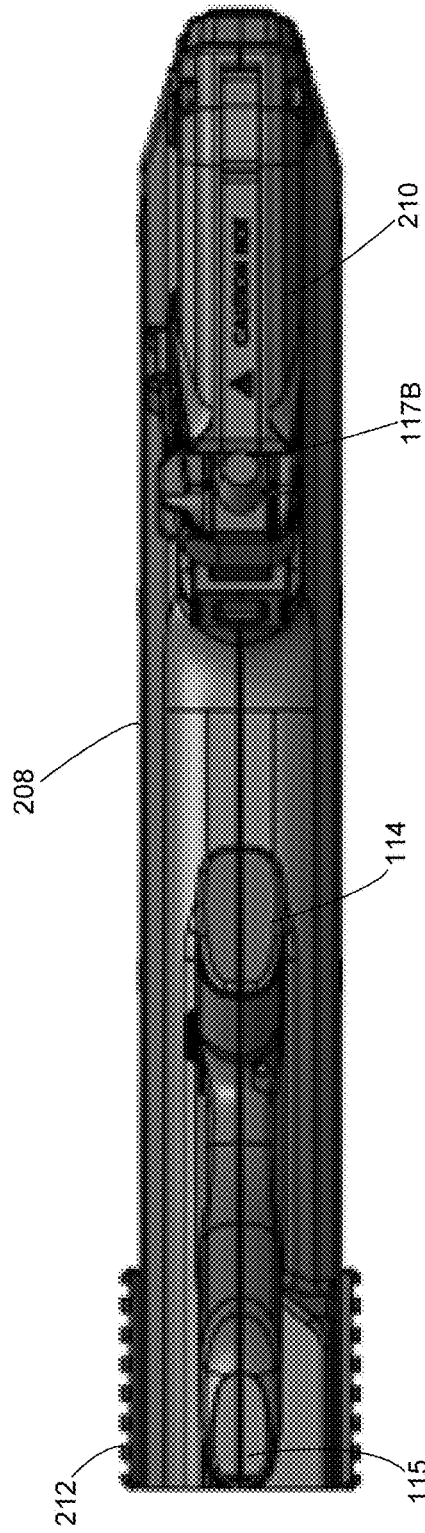

FIG. 10D

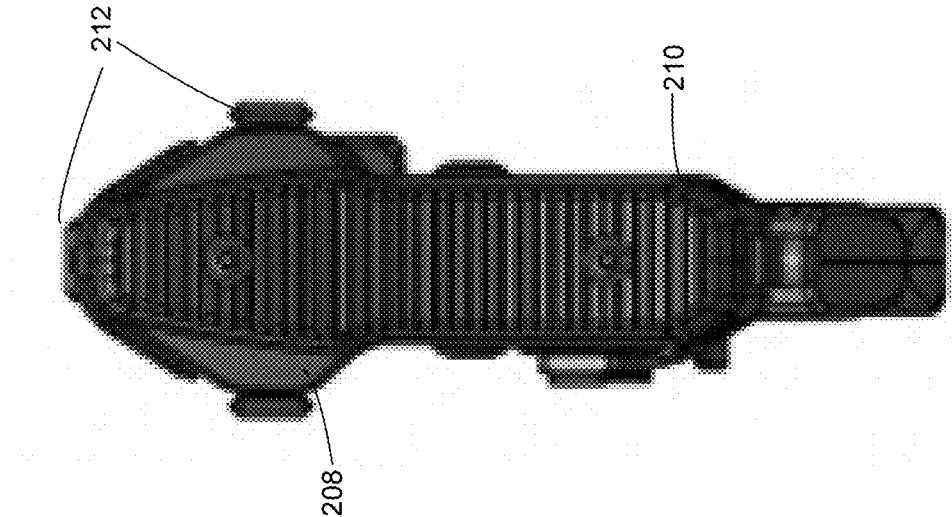

FIG. 10E

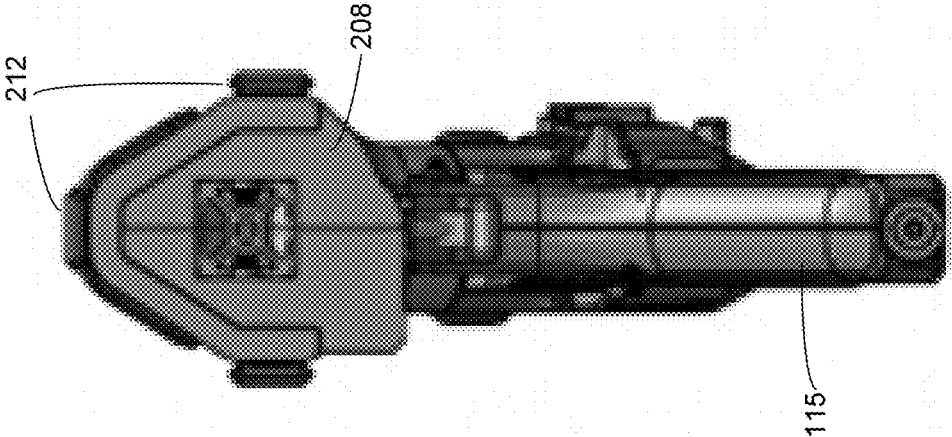

FIG. 10F

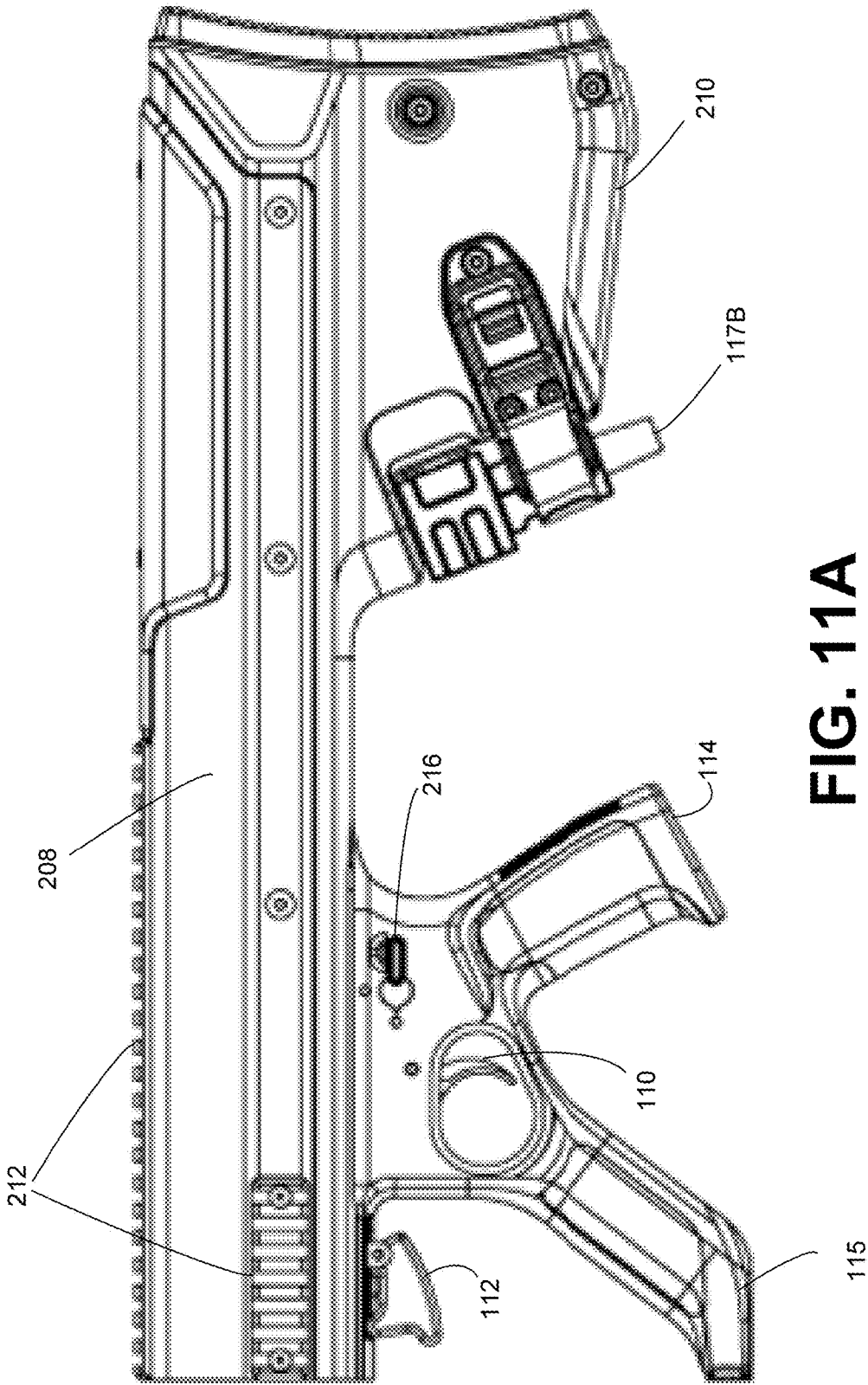

FIG. 11A

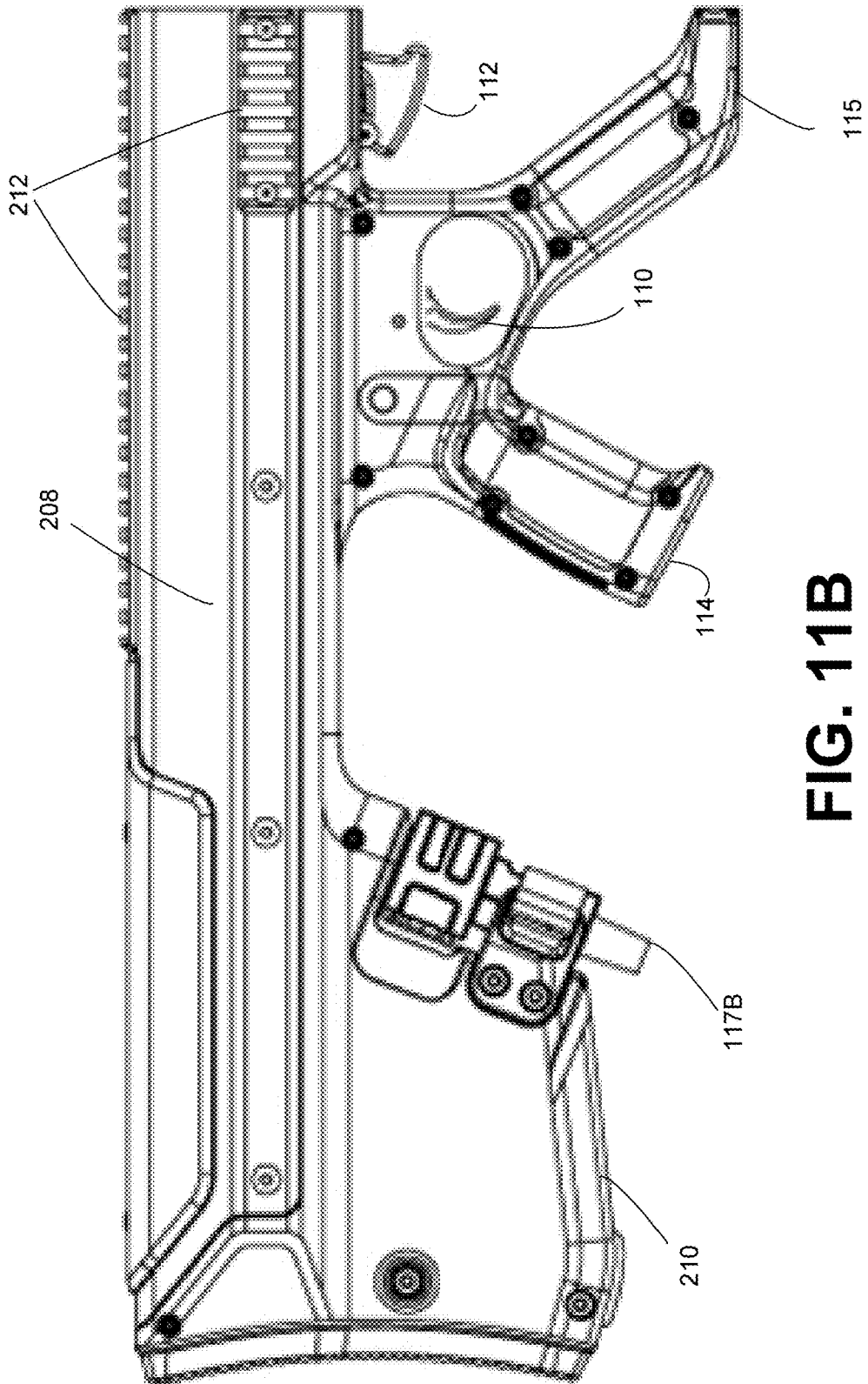

FIG. 11B

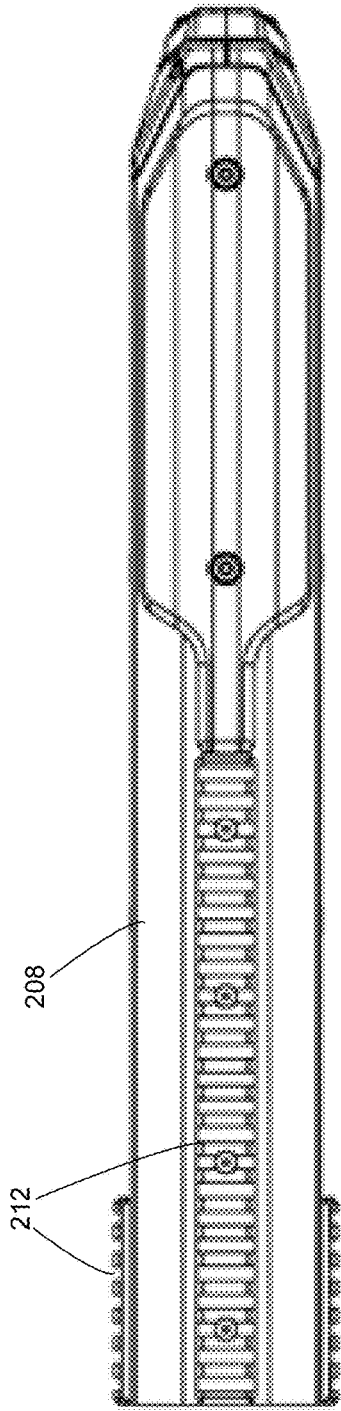

FIG. 11C

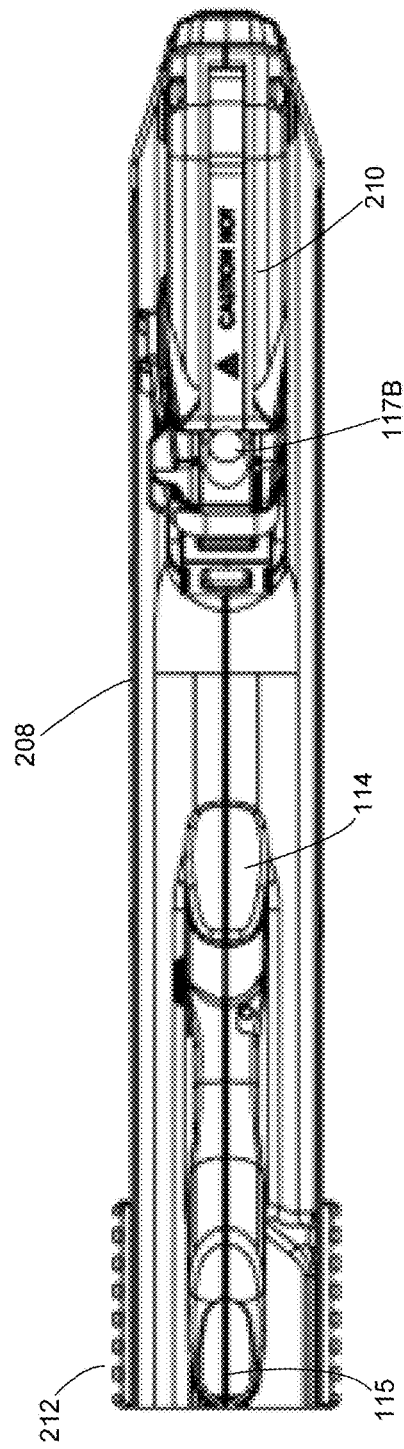

FIG. 11D

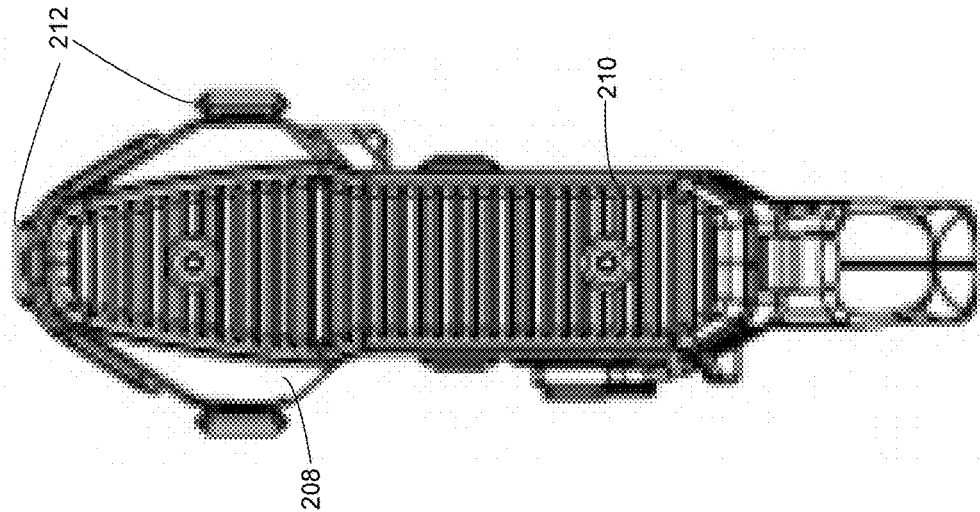

FIG. 11F

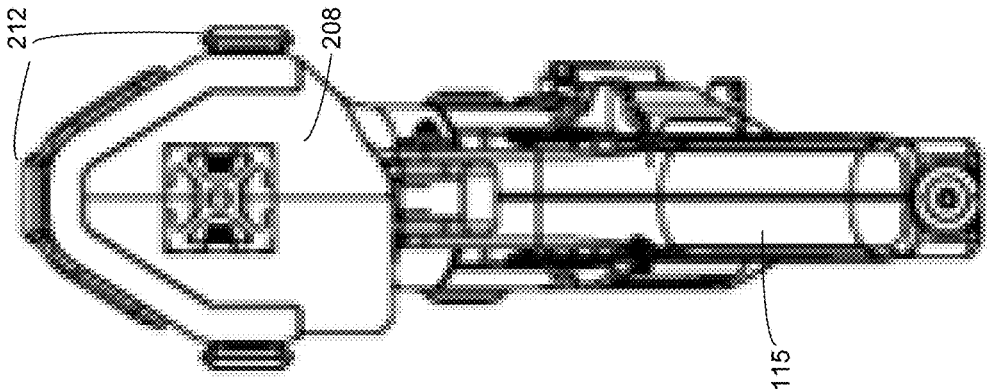

FIG. 11E

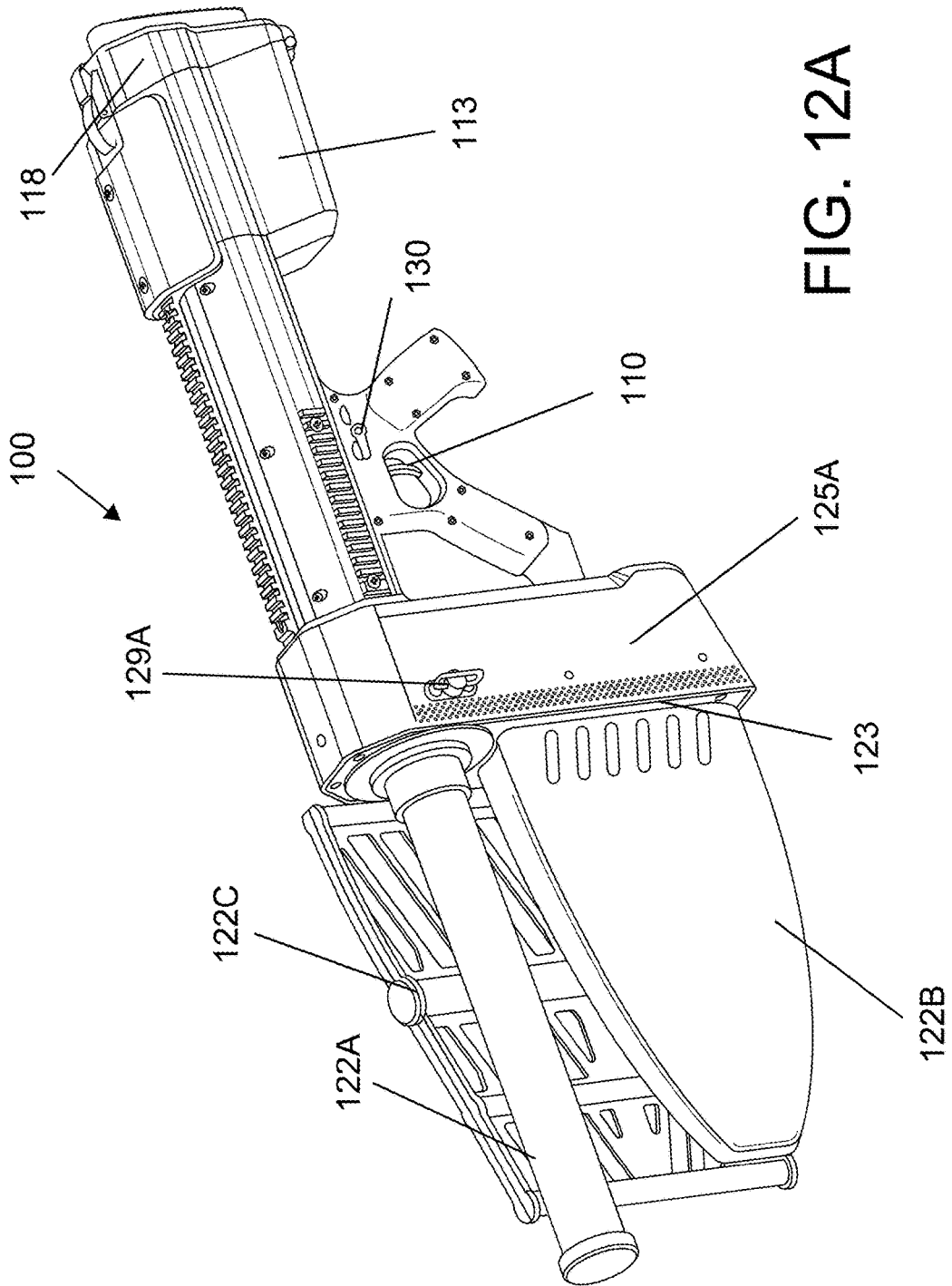

FIG. 12A

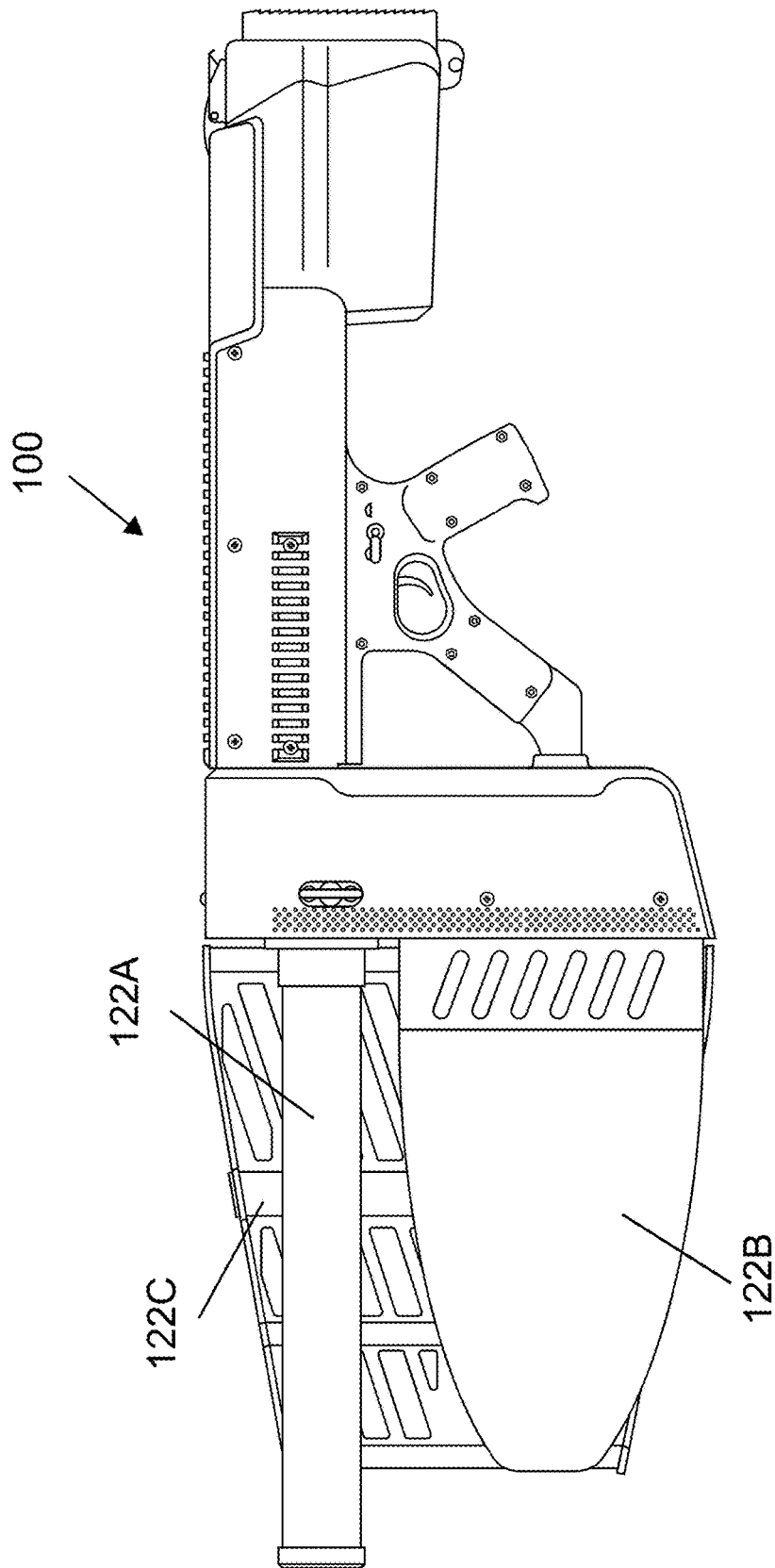

FIG. 12B

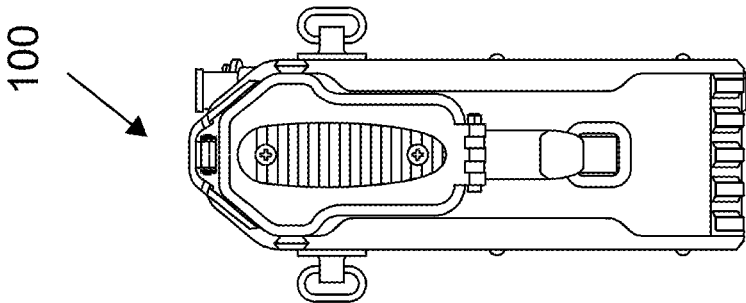

FIG. 12D

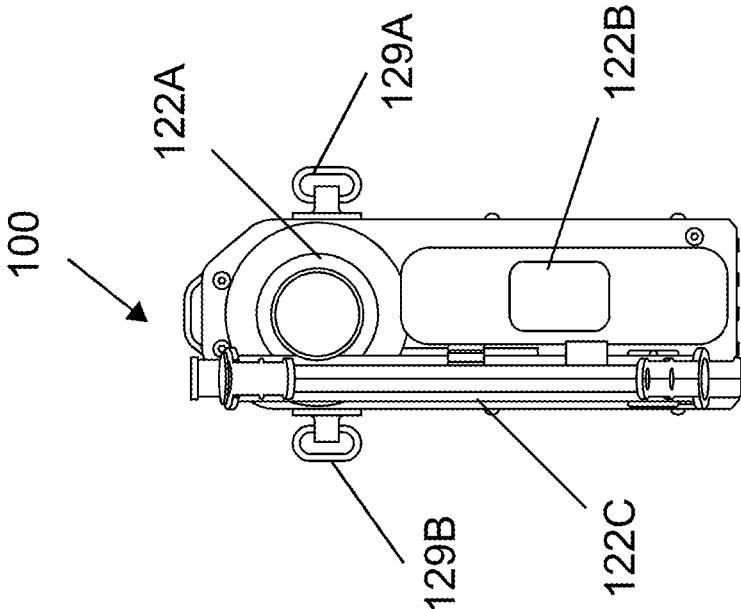

FIG. 12C

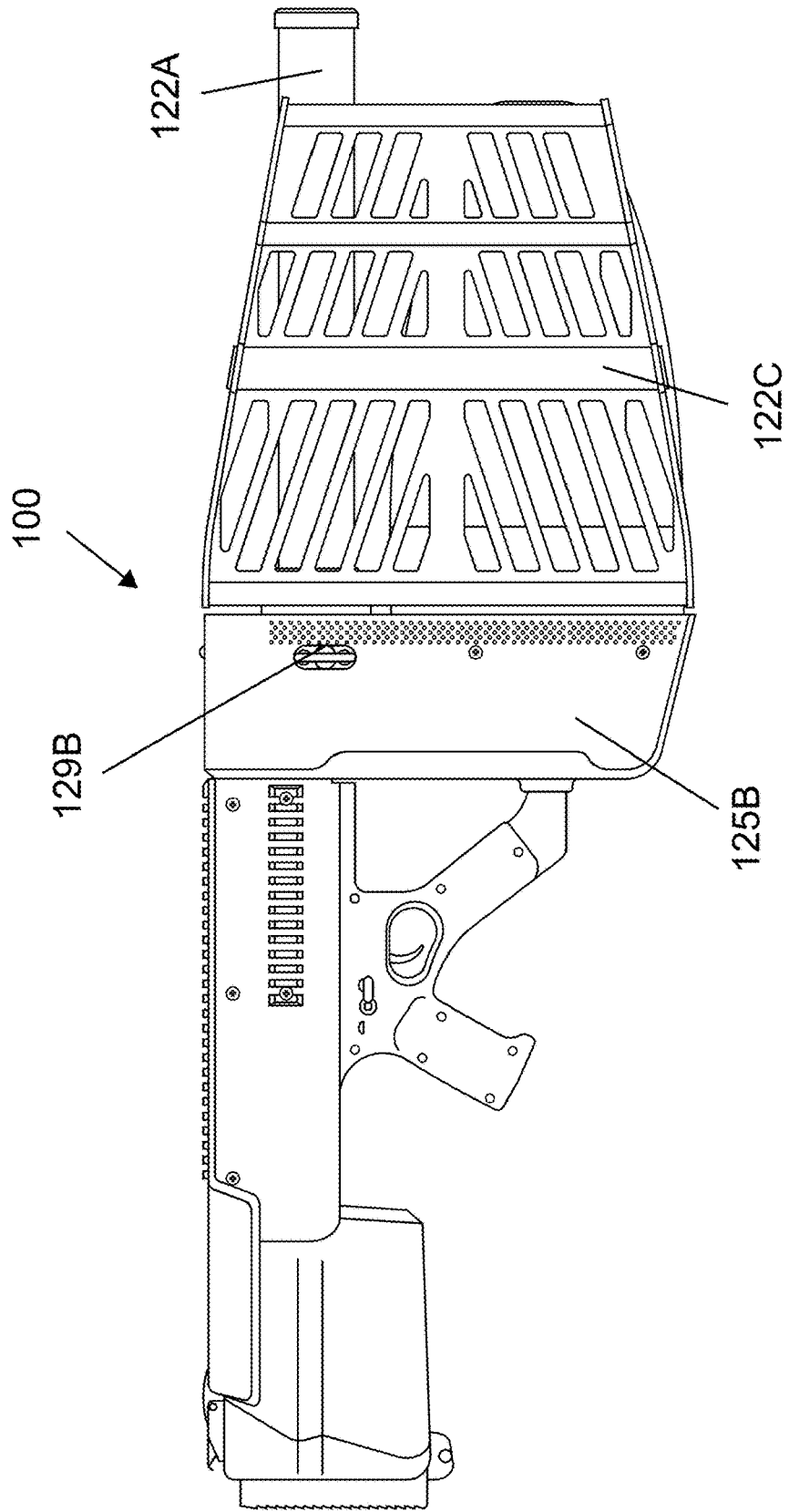
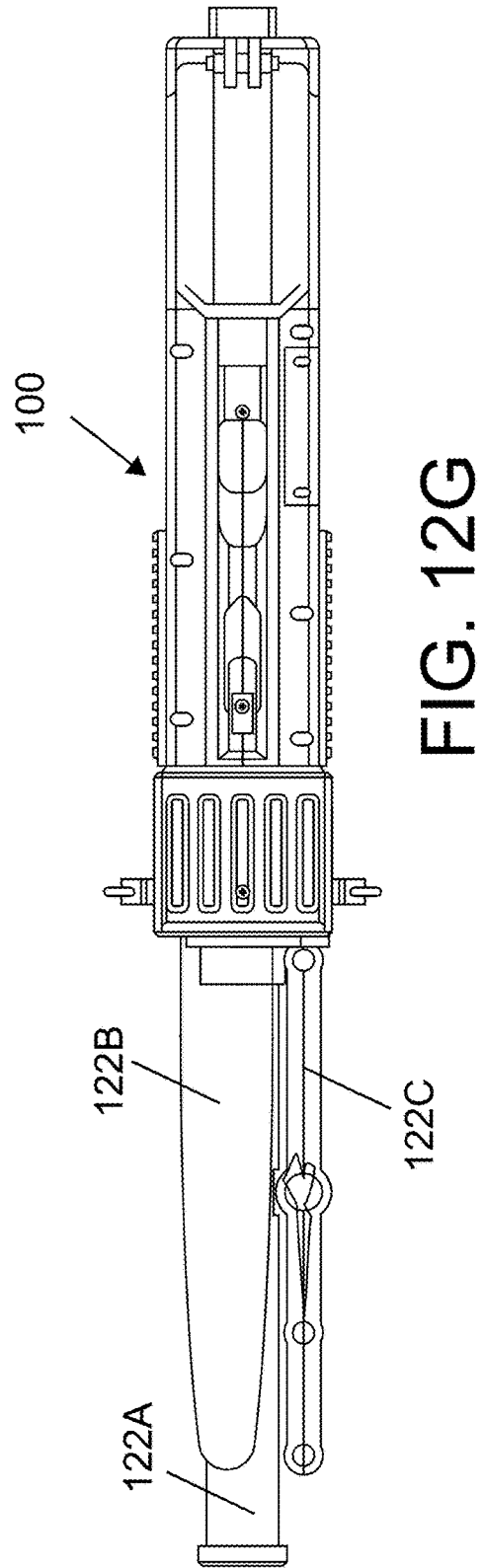
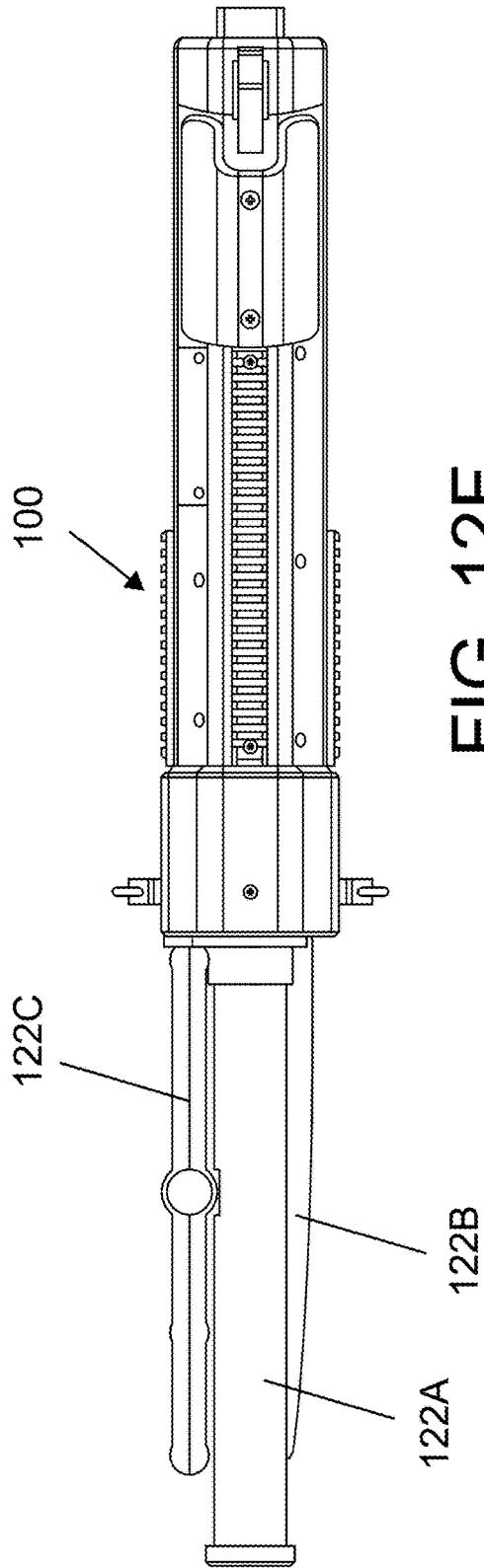
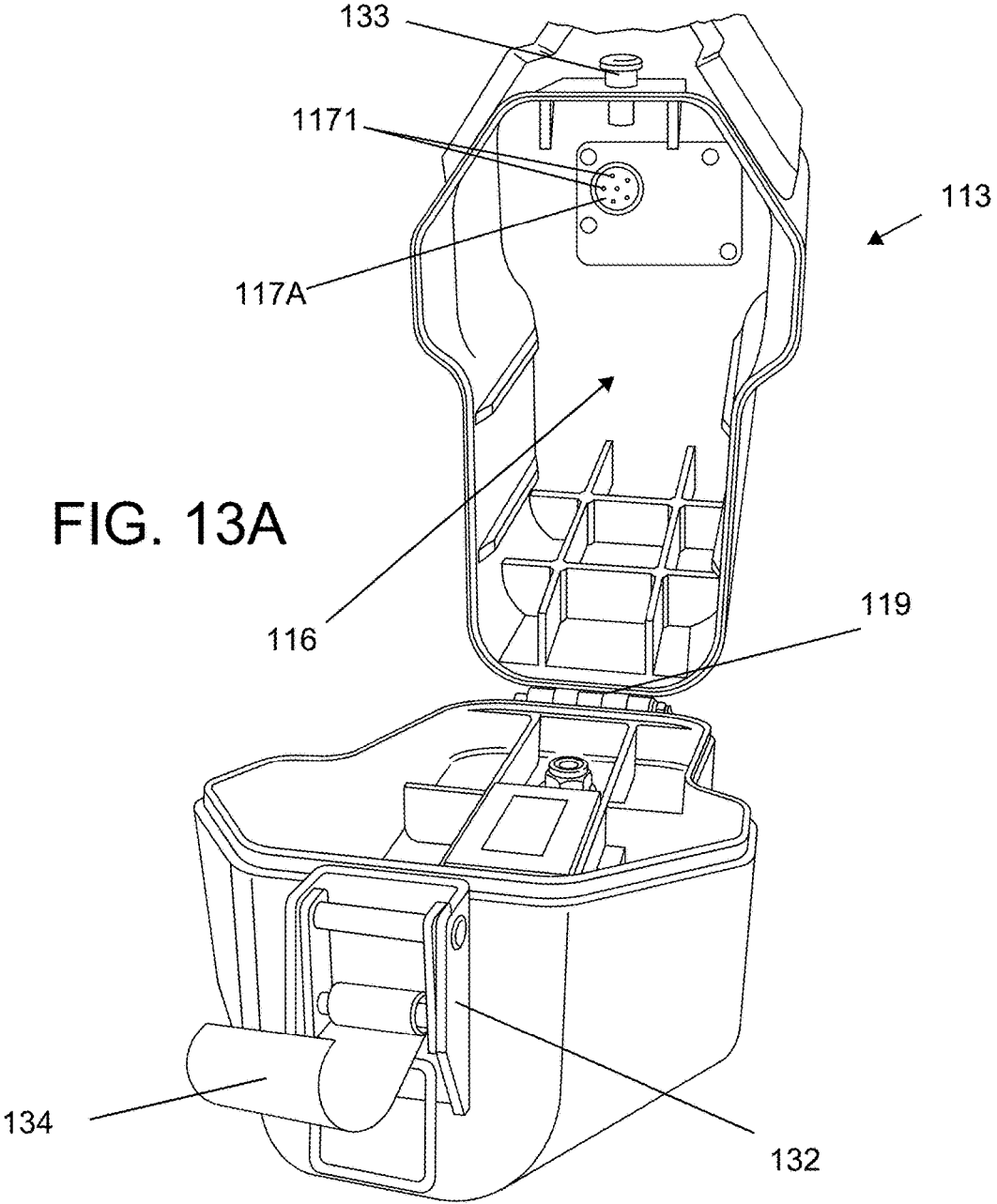

FIG. 12E





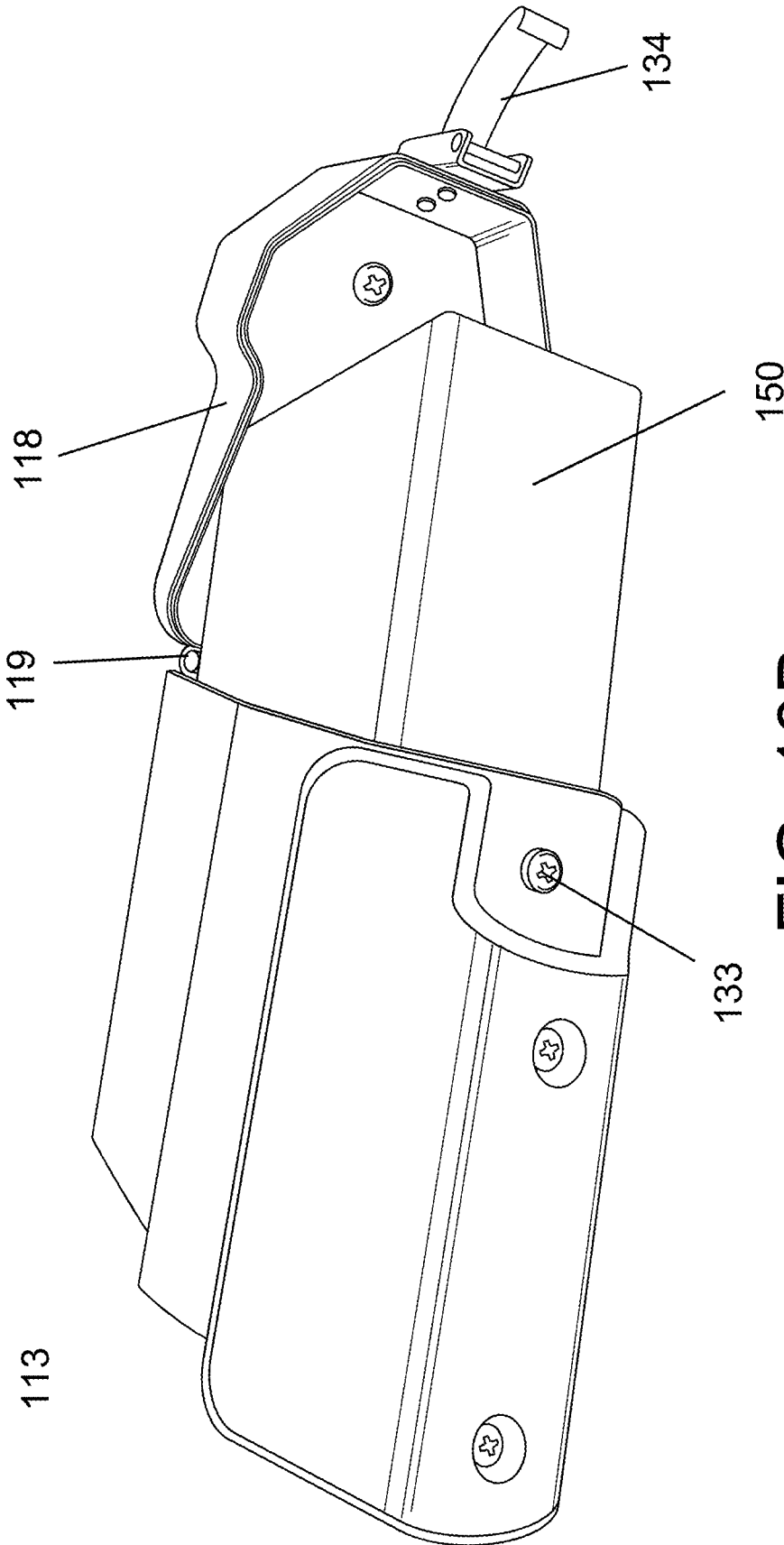

FIG. 13B

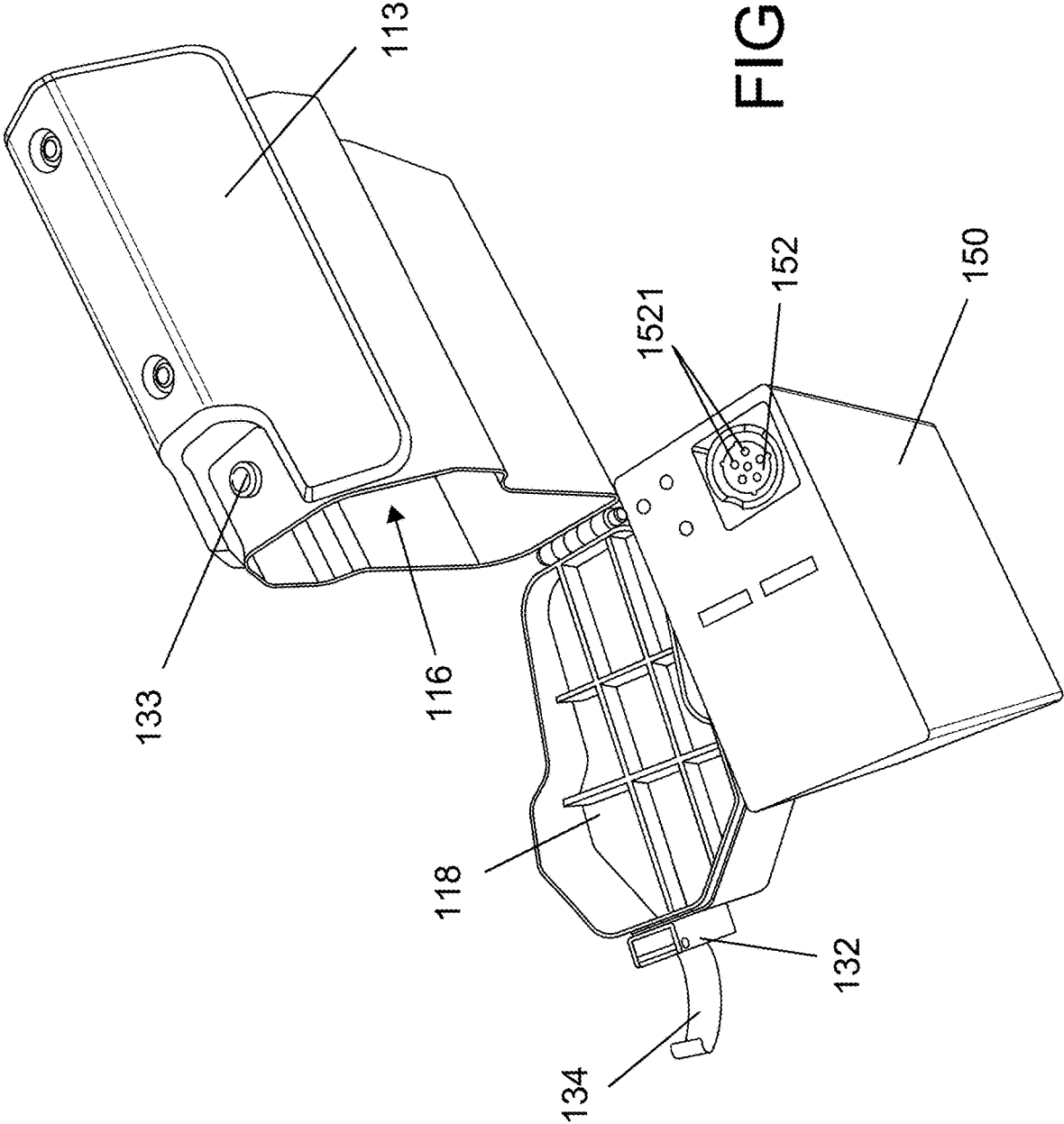

FIG. 13C

**DUAL-GRIP PORTABLE
COUNTERMEASURE DEVICE AGAINST
UNMANNED SYSTEMS**

CROSS-REFERENCE TO RELATED
APPLICATION

This application is a continuation-in-part of U.S. patent application Ser. No. 16/005,905 filed Jun. 12, 2018 and titled DUAL-GRIP PORTABLE COUNTERMEASURE DEVICE AGAINST UNMANNED SYSTEMS, which is a continuation of U.S. Pat. No. 10,020,909, filed May 16, 2017 and titled DUAL-GRIP PORTABLE COUNTERMEASURE DEVICE AGAINST UNMANNED SYSTEMS, which is a continuation-in-part of U.S. patent application Ser. No. 15/274,021, filed Sep. 23, 2016 and titled PORTABLE COUNTERMEASURE DEVICE AGAINST UNMANNED SYSTEMS, which claims priority to U.S. Provisional Patent Application Ser. No. 62/222,475, filed Sep. 23, 2015, titled ELECTRONIC DRONE DEFENDER-WIRELESS JAMMING AND SIGNAL HACKING, the disclosures of which are incorporated by reference in their entirety herein.

BACKGROUND

The following relates generally to the electronic countermeasure arts, the unmanned autonomous vehicle arts, signal jamming arts, communications arts, satellite navigation and communication arts, law enforcement arts, military science arts, and the like. It finds particular application in conjunction with the jamming and hijacking of drones and will be described with particular reference thereto. However, it will be understood that it also finds application in other usage scenarios and is not necessarily limited to the aforementioned application.

Unmanned or autonomous aerial vehicles (“UAV”), more commonly known as “drones”, have become more and more prevalent in both the military and civilian context. Current, commercially available drones embody technology that was until recently, solely within the purview of governmental entities. The drones available to the civilian and military markets include navigation systems, various types of eavesdropping components, high-definition or real-time video output, long-life lithium batteries, and the like. Furthermore, current civilian models may be operated by any individual, without regard to licensing or regulation.

The propagation of civilian drone usage has resulted in invasions of privacy, interference with official governmental operations, spying on neighbors, spying on government installations, and myriad other offensive operations. Military usage of drones, including armed drones, has increased substantially as battery storage has increased and power consumption has decreased. This widespread use of drones has led to security and privacy concerns for the military, law enforcement, and the private citizen. Furthermore, drones have substantially decreased in size, becoming smaller and smaller, while the capabilities of the drones themselves have increased. This poses a security risk for security personnel as the pilot of the drone may be far away, making the determination of the pilot’s intent particularly difficult to ascertain.

The drones in use typically operate using multiple frequency bands, some bands used for control signals between the drone and the pilot, bands for Global Navigation Satellite System (“GNSS”) signals for navigation including, for example and without limitation, GPS, GLONASS, Galileo

(EU), BeiDou Navigation Satellite System (“BDS”), and other public/proprietary satellite-based navigation systems, and other frequency bands for video and/or audio signal transmissions. This use of multiple frequencies results in difficulty in effectively tailoring a jamming signal directed solely to the offending drone, without negatively impacting other, non-offensive radio-frequency devices.

Furthermore, current commercially available jammers are generally omnidirectional in nature. To avoid issues relating to non-offensive devices, these jammers typically are limited in radius from less than a meter to 25 meters. Those jammers having larger effective radii for signal jamming or denial require substantial power (plug-in/non-portable) or are bulky. A common problem with current jammers is their inability to specifically target a drone, while allowing non-threatening devices to remain operational. Furthermore, due to the distances and heights at which drones operate, the portable jammers that are currently available lack the ability to effectively jam signals that may be used by the drones. For example, such commercially available jammers for Wi-Fi or satellite navigation will propagate a jamming signal circularly outward, rendering the operator’s own devices inoperable while within that radius. The unintended consequences of such jamming may cause vehicle accidents or aircraft issues, depending upon the strength and radius of the jammer being used.

In addition to the foregoing problems, current jammers lack the ruggedness associated with field operations. That is, the commercially available jammers are delicate electronics and are not designed for use by soldiers in the field. As noted above, the commercially available jammers further utilize multiple antennae, each directed to a different frequency band. These are not ruggedized pieces of equipment capable of being utilized in field operations by law enforcement, security, or military. The multiple antennae are prone to breakage during transport. Those rugged military or law enforcement jammers that are available are portable in the sense that they are backpack or vehicle born devices and require substantial training to effectively operate.

Previous attempts at hand-held or portable jammers utilized standard form-factors for hand-held weapons. However, these designs are intended to compensate for recoil as the weapon fires. Rifle form-factors typically utilize a two-hand approach, with the hands being spaced apart to steady the rifle when firing. This hand placement, with the weight of the average weapon, can be tiring, particularly when holding the weapon on target. Generally, because the weapon fires so quickly, the aforementioned design does not necessarily adversely affect its use. However, with directed energy weapons, which must remain on target while active, this displacement of at least one of the hands away from the body of the operator, places considerable strain on the extended arm.

Thus, it would be advantageous to provide a ruggedized form factor directional drone jammer that provides a soldier or law enforcement officer with simple, targeted anti-drone capabilities. Such a jammer is portable, including a power supply, and comprises a rifle-like form allowing the soldier or law enforcement officer to aim via optic, electronic or open sights at a target drone for jamming of the drone control and/or GNSS signals, while preventing interference for other devices utilizing the jammed frequencies. Furthermore, it would be advantageous to provide a suitable form-factor that relieves arm strain while maintaining aim on a targeted drone.

BRIEF DESCRIPTION

The following discloses a new and improved portable countermeasure device, utilizing a dual-grip embodiment, with directional targeting which addresses the above referenced issues, and others.

In one embodiment, a portable countermeasure device is provided comprising at least one directional antenna, at least one disruption component and at least one activator. The countermeasure device further includes a processor and memory in communication therewith wherein the memory stores instructions which are executed by the processor to monitor a system performance by measuring at least one performance indicator of the countermeasure device.

In another embodiment, the portable countermeasure device includes a haptic feedback component in communication with the processor configured to generate a haptic feedback pattern associated with the measured performance indicator.

In some embodiments, the measured performance indicator is at least one of a temperature, a machine state log, a battery power level, a transmission signal, a GNSS position, a time count, or an output power level, wherein the device further comprises a GNSS receiver or at least one temperature sensor in communication with the processor configured to detect a temperature of the countermeasure device.

In another embodiment, the measured performance indicator is recorded to a data log within the memory or onto a removable data storage device.

In another embodiment, a portable countermeasure device is provided having a hand-held form factor with dual-grips, the grips located adjacent each other.

According to another embodiment, a dual-grip portable countermeasure device includes a body having a first grip and a second grip, with the second grip adjacent to the first grip located on a bottom portion of the body. The dual-grip portable countermeasure device further includes at least one directional antenna affixed to a plated removably coupled to a front portion of the body, and at least one signal disruption component disposed within an interior of the body, the at least one signal disruption component in electronic communication with the at least one directional antenna.

In accordance with another embodiment, a dual-grip portable countermeasure device, includes a body that has a first grip located on a bottom portion of the body, a second grip adjacent the first grip located on the bottom portion of the body, and a hollow buttstock with a buttstock cavity formed in a rear portion of the body, with the first grip angled toward a buttstock of the body, and the second grip is angled opposite the first grip toward the front of the body. The dual-grip portable countermeasure device also includes a connector located within the buttstock cavity, the connector configured to removably couple with a power supply. Disruption components are located within the body and are in communication with the external power supply via the connector, the disruption components configured to generate a disruption signals on corresponding associated frequency bands. The dual-grip portable countermeasure device also includes a first activator coupled to the body adjacent the first grip and in operable communication with the external power supply and at least one of the disruption components. The dual-grip portable countermeasure device also includes multiple directional antennae in communication with the disruption components, the directional antennae configured to emit a corresponding plurality of disruption signals generated by the plurality of disruption components.

In another aspect, the portable countermeasure device further comprises a firearm form factor body, wherein the directional antenna is affixed to removable plate removably attached to a front portion of the firearm form factor body. The one or more disruption components may be externally or internally mounted to the firearm form factor body.

In another aspect, a power source is capable of being inserted into the buttstock cavity so as to supply power to the disruption components. Such a battery pack may comprise a lithium-ion battery, NiMH battery, or the like.

In yet another aspect, the disruption components generate disruptive signals across multiple frequency bands via at least one antenna. In some embodiments, the multiple frequency bands include GNSS, control signals, and/or Wi-Fi signals. In other embodiments, multiple antennae are used for different frequency bands.

In another aspect, a measured performance indicator is recorded to a data log within a memory or removable data storage device.

In another aspect, the processor is further configured to attenuate the output power of the amplified signal by one of pulse width modulation, voltage control of the at least one amplifier, a variable voltage attenuator, and waveform control.

In another aspect, the disruption signals including at least one of noise, spoofing, or alternate control commands are stored within the memory.

BRIEF DESCRIPTION OF THE DRAWINGS

The subject disclosure may take form in various components and arrangements of component, and in various steps and arrangement of steps. The drawings are only for purposes of illustrating the preferred embodiments and are not to be construed as limiting the subject disclosure.

FIG. 1 illustrates a cross section of a portable countermeasure device in accordance with one aspect of the exemplary embodiment.

FIG. 2A illustrates a right-side three-dimensional view of an example portable countermeasure device according to one embodiment of the subject application.

FIG. 2B illustrates a left side three-dimensional view of the example portable countermeasure device of FIG. 2A according to one embodiment of the subject application.

FIG. 2C illustrates a top three-dimensional view of the example portable countermeasure device of FIG. 2A according to one embodiment of the subject application.

FIG. 2D illustrates a bottom three-dimensional view of the example portable countermeasure device of FIG. 2A according to one embodiment of the subject application.

FIG. 2E illustrates a front three-dimensional view of the example portable countermeasure device of FIG. 2A according to one embodiment of the subject application.

FIG. 2F illustrates a rear three-dimensional view of the example portable countermeasure device of FIG. 2A according to one embodiment of the subject application.

FIG. 3A illustrates a right-side view of the example portable countermeasure device of FIG. 2A according to one embodiment of the subject application.

FIG. 3B illustrates a left-side view of the example portable countermeasure device of FIG. 3A according to one embodiment of the subject application.

FIG. 3C illustrates a top view of the example portable countermeasure device of FIG. 3A according to one embodiment of the subject application.

5

FIG. 3D illustrates a bottom view of the example portable countermeasure device of FIG. 3A according to one embodiment of the subject application.

FIG. 3E illustrates a front view of the example portable countermeasure device of FIG. 3A according to one embodiment of the subject application.

FIG. 3F illustrates a back view of the example portable countermeasure device of FIG. 3A according to one embodiment of the subject application.

FIG. 4 illustrates an external backpack containing the jammer components utilized by the example portable countermeasure device of FIG. 2.

FIG. 5 illustrates a close up view of jammer components utilized by the portable countermeasure device of the example embodiment of FIG. 2.

FIG. 6A illustrates a three-dimensional rendering of the portable countermeasure device of FIGS. 2A-3F in accordance with one aspect of the exemplary embodiment.

FIG. 6B illustrates a three-dimensional rendering of an alternate embodiment of the portable countermeasure device of FIGS. 2A-3F in accordance with one aspect disclosed herein.

FIG. 6C illustrates a three-dimensional rendering of another alternate embodiment of the portable countermeasure device of FIGS. 2A-3F in accordance with one aspect disclosed herein.

FIG. 7A illustrates a three-dimensional side view of a yagi antenna utilized by the portable countermeasure device of FIGS. 2A-3F in accordance with one embodiment.

FIG. 7B illustrates a three-dimensional top view of the yagi antenna utilized by the portable countermeasure device of FIG. 7A in accordance with one embodiment.

FIG. 7C illustrates a three-dimensional bottom view of the yagi antenna utilized by the portable countermeasure device of FIG. 7A in accordance with one embodiment.

FIG. 7D illustrates a three-dimensional front view of the yagi antenna utilized by the portable countermeasure device of FIG. 7A in accordance with one embodiment.

FIG. 7E illustrates a three-dimensional rear view of the yagi antenna utilized by the portable countermeasure device of FIG. 7A in accordance with one embodiment.

FIG. 8A illustrates a side view of the yagi antenna depicted in FIG. 7A utilized by the portable countermeasure device in accordance with one embodiment.

FIG. 8B illustrates a top view of the yagi antenna depicted in FIG. 7A utilized by the portable countermeasure device in accordance with one embodiment.

FIG. 8C illustrates a bottom view of the yagi antenna depicted in FIG. 7A utilized by the portable countermeasure device in accordance with one embodiment.

FIG. 8D illustrates a front view of the yagi antenna depicted in FIG. 7A utilized by the portable countermeasure device in accordance with one embodiment.

FIG. 8E illustrates a rear view of the yagi antenna depicted in FIG. 7A utilized by the portable countermeasure device in accordance with one embodiment.

FIG. 9A illustrates a close-up view of the dual-grip configuration of the portable countermeasure device of FIGS. 2A-3F in accordance with one aspect of the exemplary embodiment.

FIG. 9B illustrates another close-up view of the dual-grip configuration of the portable countermeasure device of FIGS. 2A-3F in accordance with one aspect of the exemplary embodiment.

6

FIG. 10A illustrates a three-dimensional left side view of the dual-grip configuration of the portable countermeasure device of FIGS. 9A-9B in accordance with one embodiment of the subject application.

FIG. 10B illustrates a three-dimensional right-side view of the dual-grip configuration of the portable countermeasure device of FIGS. 9A-9B in accordance with one embodiment of the subject application.

FIG. 10C illustrates a three-dimensional top view of the dual-grip configuration of the portable countermeasure device of FIGS. 9A-9B in accordance with one embodiment of the subject application.

FIG. 10D illustrates a three-dimensional bottom view of the dual-grip configuration of the portable countermeasure device of FIGS. 9A-9B in accordance with one embodiment of the subject application.

FIG. 10E illustrates a three-dimensional rear view of the dual-grip configuration of the portable countermeasure device of FIGS. 9A-9B in accordance with one embodiment of the subject application.

FIG. 10F illustrates a three-dimensional front view of the dual-grip configuration of the portable countermeasure device of FIGS. 9A-9B in accordance with one embodiment of the subject application.

FIG. 11A illustrates a left-side view of the dual-grip configuration of the portable countermeasure device of FIGS. 9A-9B in accordance with one embodiment of the subject application.

FIG. 11B illustrates a right-side view of the dual-grip configuration of the portable countermeasure device of FIGS. 9A-9B in accordance with one embodiment of the subject application.

FIG. 11C illustrates a top view of the dual-grip configuration of the portable countermeasure device of FIGS. 9A-9B in accordance with one embodiment of the subject application.

FIG. 11D illustrates a bottom view of the dual-grip configuration of the portable countermeasure device of FIGS. 9A-9B in accordance with one embodiment of the subject application.

FIG. 11E illustrates a rear view of the dual-grip configuration of the portable countermeasure device of FIGS. 9A-9B in accordance with one embodiment of the subject application.

FIG. 11F illustrates a front view of the dual-grip configuration of the portable countermeasure device of FIGS. 9A-9B in accordance with one embodiment of the subject application.

FIG. 12A illustrates a perspective of the portable countermeasure device of FIG. 1 in accordance with one aspect of the exemplary embodiment.

FIG. 12B illustrates a left-side view of the example portable countermeasure device of FIG. 12A according to one embodiment of the subject application.

FIG. 12C illustrates a front three-dimensional view of the example portable countermeasure device of FIG. 12A according to one embodiment of the subject application.

FIG. 12D illustrates a rear three-dimensional view of the example portable countermeasure device of FIG. 12A according to one embodiment of the subject application.

FIG. 12E illustrates a right-side view of the example portable countermeasure device of FIG. 12A according to one embodiment of the subject application.

FIG. 12F illustrates a top three-dimensional view of the example portable countermeasure device of FIG. 12A according to one embodiment of the subject application.

FIG. 12G illustrates a bottom three-dimensional view of the example portable countermeasure device of FIG. 12A according to one embodiment of the subject application.

FIG. 13A illustrates a rear perspective view of a buttstock according to one embodiment of the subject application.

FIG. 13B illustrates a top perspective view of a buttstock and battery according to one embodiment of the subject application.

FIG. 13C illustrates a perspective view of a buttstock according to one embodiment of the subject application.

DETAILED DESCRIPTION

One or more embodiments will now be described with reference to the attached drawings, wherein like reference numerals are used to refer to like elements throughout. Aspects of exemplary embodiments related to systems and methods for signal jamming and signal hijacking are described herein. In addition, example embodiments are presented hereinafter referring to a rifle-like apparatus that may be aimed by a soldier or law enforcement officer on a drone to disrupt control and/or navigation of the drone, however application of the systems and methods set forth can be made to other areas utilizing electronic countermeasures and privacy protection.

As described herein, there is described a portable countermeasure device, such as rifle-like or firearm form factor jammer, that can be aimed by an operator at a drone, resulting in the disruption of control and/or navigation signals. In one embodiment, the portable countermeasure device includes multiple signal generators and associated amplifiers, producing disruptive, spoofing and/or jamming signals across multiple frequency bands. It will be appreciated by those skilled in the art that suitable disruptive signals may include, for example and without limitation, multi- or single frequency noise signals, alternative command signals, false data signals, and the like. In such an embodiment, at least one antenna is coupled to the portable countermeasure device, capable of directing multiple frequency bands of disruptive signals toward a single target, forming a cone around the target. The portable countermeasure device may be self-contained, with replaceable battery packs, or receive power from an external source.

It will be appreciated that the various components of the portable countermeasure device, as described in greater detail below, may be added to an existing fire arm, an aftermarket rifle stock, or a firearm-like form factor having a customized body incorporating the various components. The portable countermeasure device may be aimed via at least one sight device including, iron sights, an optical scope, or other means for directing the disruptive signals toward a targeted drone. Furthermore, the embodiments disclosed herein may be implemented without complex software, hardware, enabling a soldier or law enforcement officer to use the portable countermeasure device without substantial training. Such a simplified implementation further ruggedizes the portable countermeasure device for use in harsh environments where weather, lack of resupply, insurgents, criminals, or the like, may operate.

Referring now to FIG. 1, there is shown a cross-section of a portable countermeasure device 100 in accordance with one exemplary embodiment of the subject application. As illustrated in FIG. 1, the portable countermeasure device 100 may be implemented in a firearm-like form factor, providing ease of use and familiarization to the operator. Accordingly, the portable countermeasure device 100 provides a soldier or law enforcement officer (operator) with the ability to spe-

cifically target a particular drone with disruptive signals, while minimizing the impact of the generated signal on other, non-targeted devices. It will be appreciated that the various components depicted in FIG. 1 are for purposes of illustrating aspects of the exemplary hardware are capable of being substituted therein.

It will be appreciated that the portable countermeasure device 100 of FIG. 1 is capable of implementation in a variety of handheld or portable form factors and the illustrations depicted and discussed hereinafter provide exemplary, and non-limiting, form factors contemplated hereunder. As shown in FIG. 1, the portable countermeasure device 100 comprises a body 102 including a processor 101 that executes, a memory 103 that stores computer-executable instructions for providing the various functions, calculations, selections and the like described herein, and signal disruption components 104 in communication therewith, e.g., at least one signal generator 106 and at least one amplifier 108. The processor 101 and memory 103 are physically coupled together with various other electronic components via microprocessor board 105.

The processor 101 can be any of various commercially available processors. The at least one processor 101 can be variously embodied, such as by a single-core processor, a dual-core processor (or more generally by a multiple-core processor), a digital processor and cooperating math coprocessor, a digital controller, or the like. The processor 101, in addition to controlling the operation of the countermeasure device 100, executes instructions stored in memory 103 for performing the various functions described more fully below.

The memory 103 may represent any type of non-transitory computer readable medium such as random-access memory (RAM), magnetic disk or tape, optical disk, flash memory, or holographic memory. In one embodiment, the memory 103 comprises a combination of random-access memory and read only memory. In some embodiments, the processor 101 and memory 103 may be combined in a single chip. Memory 103 may store data the processed in the method as well as the instructions for performing various exemplary functions.

The memory 103 suitably includes firmware, such as static data or fixed instructions, such as BIOS, system functions, configuration data, and other routines used for the operation of the countermeasure device 100 via the processor 101. The memory 103 is further capable of providing a storage area for data and instructions associated with applications and data handling accomplished by the processor 101. The memory 103 may further include one or more instructions, or modules, configured to be executed by the processor 101 to perform one or more operations, such as operations associated with the countermeasure device 100, which operations are described in greater detail below.

The illustration of FIG. 1 depicts a portable countermeasure device 100 that utilizes a dual-grip configuration, having a first grip 114 in location typical with the typical pistol-grip rifle, and second grip 115 in relatively close proximity to the first grip 114. In some embodiments, as illustrated hereinafter, the first and second grips 114 and 115 may be adjacent to each other, with the second grip 115 cantilevered or angled forward, towards the front 10 of the device 110 and the first grip 114 cantilevered or angled back towards the rear 11 of the device 110. In other embodiments, as will be appreciated by those skilled in the art, the body 102 may, for example and without limitation, resemble a commonly used rifle, including, without limitation, M4 carbine, M14, AR-platform, or the like, comprising an upper

receiver and a lower receiver, as well as other rifle designs, as will be appreciated by those skilled in the art including, for example, modular rifle designs, standard rifle designs, and the like. Depending upon the configuration of the portable countermeasure device **100**, the microprocessor board **105** and/or the signal disruption components **104** may be contained in the upper receiver, the lower receiver, or both.

The body **102** may be constructed of non-metallic materials, i.e., ballistic plastic, carbon fiber, ceramics, etc., or suitable non-transmissive metallic composites. The body **102** may be implemented in a suitable form factor with which soldiers and/or law enforcement personnel are already familiar, e.g., the aforementioned M4 carbine, AR-platform, AK-platform, SCAR, bullpup, etc. It will be appreciated that the width, length, and height of the body **102** may be dependent upon the size and number of generators **106** and amplifiers **108** either integral therein or externally affixed thereto. According to one embodiment, a multifunctional cell is formed as the body **102** to provide both structural support/shape of the portable countermeasure device **100** as well as supply power to the components therein. A suitable example of such a multifunctional cell is provided in PCT/US2013/040149, filed May 8, 2013 and titled MULTIFUNCTIONAL CELL FOR STRUCTURAL APPLICATIONS, the entire disclosure of which is incorporated by reference herein. In accordance with another embodiment, the portable countermeasure device **100** may include multiple signal disruption components **104** to combat a variety of potential targets, e.g., receivers of improvised explosive devices (IEDs), commercial drones, military drones, or other portable electronic devices of enemy combatants or suspects, e.g., cellular phones, GNSS-based navigation devices, remote control detonators, etc. A suitable example of a portable countermeasure device **100** that includes multiple signal disruption components **104** within the body **102** is depicted in FIG. **12A** et seq., as discussed below.

The portable countermeasure device **100**, as shown in FIG. **1**, includes a first activator **110**, located adjacent to the first grip **114**. In some embodiments and as shown in FIG. **2A**, a portable countermeasure device **200** may also include a second activator **112**, located adjacent to the second grip **115** on underside of the body **102**. It will be understood that the portable countermeasure device **100** may be implemented with a single activator, whereby multiple disruptive signals are generated via the activation of the single activator. The activator, such as activator **110** and/or **112**, as will be appreciated, is operable to close a circuit or "firing mechanism" (not shown) to allow power to flow from the power source, e.g., backpack (not shown), AC power (not shown), or optional, battery pack (not shown), to the signal generator **106** and amplifier **108** of the signal disruption components **104**. It will be appreciated that the activator **110** or **112** may be implemented as typical firearm triggers, toggle switches, spring-loaded buttons, or the like. According to one embodiment, the first activator **110** is operable to activate control circuitry for transmitting signals for the disruption of control frequency bands, while the second activator **112** is operable to activate control circuitry for disruption of GNSS/navigation bands. It is to be appreciated that either activator **110**, **112** may active the control circuitry for transmitting any desired signal or combination of signals. Furthermore, in embodiments with a single activator, an operator of the countermeasure device **100** may, via operator input, select a desired transmitting signal. An example implementation of the dual activators **110-112** is

embodied in the portable countermeasure device **200** of FIGS. **2A-3F**, discussed below.

Returning to FIG. **1**, in accordance with one embodiment, the signal generator **106** and corresponding amplifier **108**, may be configured to generate signals from DC to 30 GHz. In another embodiment, a signal generator **106**, with a corresponding amplifier **108**, is configured to generate disruptive signals in the, 70-75 MHz, 400-500 MHz, 800-900 MHz, 900-1000 MHz, 1000 MHz-1.8 GHz, 2.0 GHz-2.6 GHz, 5.0-5.6 GHz frequency ranges, common cellular frequency bands, IEEE HF, VHF, UHF, L, S, C, X, Ku, K, Ka, V, W, or mm bands, or other known control/navigation signal frequency ranges. In one particular embodiment, a signal generator **106** for each of the 72 MHz frequency band, the 433 MHz frequency band, the 800 MHz frequency band, the 915 MHz frequency band, the 1.2 GHz frequency band, 1.3 GHz frequency band, the 1.5 GHz frequency band, the 2.4 GHz frequency band, and the 5.8 GHz frequency band, with corresponding amplifiers **108** are incorporated into the portable countermeasure device **100**. Additionally, the signal generator **106** may be in communication with memory **103** that stores alternative command signals for spoofing or hacking, as will be known in the art, at a particular control frequency. In such embodiments, the signal generator **106** may be operable to transmit a different navigation signal (altering the coordinates the drone is receiving from navigation satellites/commands), transmit a control signal indicating the drone should land or return to home, or the like. It will be appreciated that such signals generated via the signal generator **106** may be output in addition to noise, jamming, or the like, or in place thereof.

In some embodiments, a power supply (not shown) supplies suitable power to the microprocessor board **105** and disruption components **104** of the portable countermeasure device **100**. In one non-limiting example, the power supply may be implemented as a rechargeable battery, including, for example and without limitation, a lithium-ion battery, a lithium ion polymer battery, a nickel-metal hydride battery, lead-acid battery, nickel-cadmium cell battery, or other suitable, high-capacity source of power. In other embodiments, a non-rechargeable battery may be utilized, as will be appreciated by those skilled in the art. According to one exemplary embodiment, the power supply is implemented in a magazine form factor, capable of insertion into a battery well (similar to the magazine well of the lower receiver of a rifle). It will be appreciated that such an implementation will be natural to a soldier or law enforcement officer, allowing utilization of existing magazine carrying devices for carrying additional battery packs, familiarity with changing a battery pack, as well as maintain the balance of the portable countermeasure device **100** similar to those rifles with which the soldier or law enforcement officer is most familiar.

In accordance with the exemplary embodiment of FIG. **1**, the portable countermeasure device **100** includes a buttstock cavity **116** within a buttstock **113**. The buttstock cavity **116** is configured to receive and accept a portable, i.e. removable battery (e.g., replaceable battery **150** of FIG. **13C**) to power the countermeasure device **100**. The buttstock cavity **116**, may be accessed by opening a hinged buttstock door **118**. The buttstock door **118**, at the rear end **11** of the buttstock **113** is capable of pivoting from a closed position, shown in FIG. **1**, to an open position about hinge **119**, illustrated and described in greater detail with respect to FIGS. **13A-C**. When the buttstock door **118** is in the open position, the removable battery **150** is able to be placed within the buttstock cavity **116** and engage a suitable coupling **117A**.

11

Closing the buttstock door **118** secures the removable battery **150** within the buttstock cavity **116** ensures proper connectivity between a battery connection and coupling **117A**. In some embodiments, the closed buttstock door **118**, provides a force that urges the removable battery **150** to engage connector **117A**. Providing a removable/replaceable/rechargeable battery **150** within the buttstock cavity **116** may aid in weight balancing the countermeasure device **100** about the dual-grip portions **114** and **115**.

In some embodiments, the portable countermeasure device **100** may utilize an auxiliary cable to a backpack power supply, a remote power source, a portable generator, fuel cell, vehicle interface, or the like. As shown in FIG. **1**, a suitable coupling **117A** is illustrated as positioned within the buttstock cavity **116**, enabling the attachment of a replaceable battery **150** or a suitable power cable from various sources, e.g., a battery stored in a backpack, hip/fanny pack, secured to MOLLE webbing, or the like. Furthermore, the skilled artisan will appreciate that the battery pack is not limited in form and can be complementary to the form-factor of the portable countermeasure device **100**, for example, similar to a rectangular magazine, tubular magazine, and the like, as well as being integrated within the body **102** of the portable countermeasure device **100**, i.e., a structural battery as discussed above.

According to another embodiment, the portable countermeasure device **100** may include a display **120** operable to display remaining power levels of the battery pack, effective range of the output of the signal disruption components **104** relative to power supply level, or the like. This optional display **120** may be connected to control components such as those components present on microprocessor board **105** and be customized to display the frequency selected for output by the jammer components **104**. In such an embodiment, the display **120** may be implemented as an LED, LCD, OLED, or other suitable display type. In accordance with one embodiment, the display **120** of the portable countermeasure device **100** may be implemented as a visual indicator associated with operation of the various components of the device **100**. It will be appreciated that as the portable countermeasure device **100** does not provide physical recoil when operated, the display **120** provides visual feedback to the operator. As indicated above, one or more LEDs, or other suitable visual indicators, may be utilized, indicating, for example and without limitation that individual circuit cards are powered up, that individual circuit cards are within specified limits, that power is on to the operating/selected antennae, which antennae are operating, and the like.

In accordance with another embodiment, the portable countermeasure device **100** is equipped with a haptic feedback component **121**, configured to provide haptic feedback through the body **102** (or grips **114**, **115**) to the operator when the portable countermeasure device **100** is active. In varying embodiments, the haptic feedback component **121** may be activated when one or more triggers **110**, **112** are engaged and power to the signal disruption components **104** is on. In such embodiments, the haptic feedback generated by the component **121** may differ so as to indicate which antenna(e) **122A-C** of FIGS. **1** and **12A-G** (see also antenna (e) **202**, **204**, and **206** of FIG. **2A-3F**) is engaged. As with other directed energy devices, e.g., lasers, RF generators, radar jammers, etc. having weapons form factors used in electronic warfare, the portable countermeasure device **100** of the subject application does not provide any observable recoil when activated. Accordingly, the haptic feedback component **121** may provide varying feedback to triggers

12

110 and/or **112**, grips **114** and/or **115**, buttstock **113**, etc., indicating activation of the portable countermeasure device **100**.

In some embodiments and as shown in FIG. **1**, the haptic feedback component **121** is a haptic activator placed within the grip **114**. While illustrated within the grip **114**, it is to be appreciated that the haptic activator may be placed in other locations, for example and without limitation, grip **115** and buttstock cavity **116**. The haptic feedback component **121** may be variously embodied for example and without limitation, as an eccentric rotating mass (ERM) actuator composed of an unbalanced weight attached to a motor shaft; a linear resonant actuator (LRA), which provides feedback by moving a mass in a reciprocal manner by means of a magnetic voice coil; a piezoelectric actuator; and/or, a combination of haptic actuators.

In some embodiments, the haptic feedback component **121** is in communication with the processor **101**. That is, the processor **101** may control the activity of the haptic component **121** in order to create at least one haptic feedback pattern intended to communicate information to an operator of the countermeasure device **100**. For example, the processor **101** may cause the haptic feedback component **121**, to vibrate continuously for a period of time. As another example of a haptic feedback pattern, the processor **101** may cause the haptic feedback component **121** to vibrate in short pulses, the short pluses may be spaced within a predetermined time. That is, the haptic feedback component **121** may provide a haptic feedback pattern of pulsing twice, pausing for a period of time (1 second), and repeating. The memory **103**, may store the instructions for producing various haptic feedback patterns. It is to be understood that the example haptic feedback patterns are non-limiting and that any combination of duration of pulsing and pauses may be used.

In some embodiments, the haptic feedback component **121**, generates a haptic feedback pattern associated with an operational state of the countermeasure device **100**. For example, if the processor **101** detects an issue with the operation of the device **100**, a haptic feedback pattern associated with a particular issue may be generated. In this way, an operator of the countermeasure device **100** is alerted to the issue and may take corrective action. For example, the processor **101** may detect that a battery of the countermeasure device is low and cause the haptic feedback component **121** to generate a haptic feedback pattern associated with low battery power (e.g., two short pluses, followed by a two second pause, repeating). The operator, recognizing the haptic feedback pattern, is alerted to the low power issue and may replace the battery on the countermeasure device **100**.

In some embodiments, the haptic feedback component **121** and processor **101** generate a haptic feedback pattern associated with a self-monitoring state described in greater detail below. In varying embodiments, the haptic feedback component **121** may be in communication with a selector (e.g., shown at **130** in FIG. **12A**), such that the haptic feedback pattern generated corresponds to a mode of operation selected with the selector upon activation of the portable countermeasure device **100**.

The portable countermeasure device **100** depicted in FIGS. **1** and **12A-G** utilizes at least one directional antenna **122A-C**, extending outward from the body **102** in a direction away from the operator. It will be understood that the countermeasure device **100** may utilize multiple directional antennae **122A**, **122B**, **122C**, in accordance with the number of disruptive signals to be generated, the types of disruptive signals, desired range, and the like, as described below. It will be appreciated that, maintaining a suitable comparison

to a rifle, the at least one antenna 122A-C replaces the barrel of a rifle, thereby maintaining familiarity and ease of operation by the soldier or law enforcement officer. In accordance with some embodiments, the at least one antenna 122A-C may be “hot-swappable” or “replaceable” in the field, allowing for different directional antennae to be used by the portable countermeasure device 100 in accordance with the battlefield conditions. For example, the distances involved in commercial drone disruption may utilize less power-intensive disruptive signals than military drone disruption. In such an embodiment, a suitable antenna may not need to be as large, or a different design antenna may be used. In another example, in the event that the at least one antenna 122A-C is damaged while in the field, an expedient repair capable of being performed by the soldier or law enforcement officer is replacement of the at least one antenna 122A-C, as opposed to having to submit the portable countermeasure device 100 to an armorer or electronics specialist for repair, thereby keeping the portable countermeasure device 100 operative.

In some embodiments the at least one antenna 122A-C is/are attached to a plate 123. The plate 123, may be removably attachable to the body 102 of the countermeasure device 100. That is, the single plate 123 containing at least one antenna, is able to be removed from the countermeasure device 100 and replaced with another plate, similar to plate 123, containing at least one antenna. Thus, in case an issue arises with the transmission components the countermeasure device 100 experiences very little down time in replacement. In simple terms, the plate 123 and at least one antenna 122A-C, are plug and play components allowing for “hot swap” in the field.

In one particular embodiment, the at least antenna 122A-C is implemented as a combined, high-gain, directional antenna having a helical cross-section. Other suitable directional antenna, e.g., Yagi, cylindrical, parabolic, log periodic array, spiral, phased array, conical, patch, etc., are also capable of being utilized in accordance with the disclosure set forth herein.

Affixed to the top of the body 102, either fixed thereto, or removably attached, e.g., attachments to a rail, is at least one sight 124, allowing for aiming by the soldier or law enforcement officer of the portable countermeasure device 100 at a target drone. In other embodiments, particularly when the top of the body 102 includes the aforementioned rails, a wide or narrow field of view optical sight may be utilized to allow the soldier or law enforcement officer to target drones beyond the normal field of vision. To avoid unintentional disruption of nearby devices outside the disruption cone 126 directed by the antenna, the at least one sight 124 may be constructed of a suitable non-metallic material. The disruption cone 126 may range from 0 degrees to 180 degrees, including for example and without limitation, 0 to 120 degrees, 0 to 90 degrees, 0-45 degrees, 20 to 30 degrees or variations thereof. The effective range of the portable countermeasure device 100 may extend outward from the at least one antenna 122A-C at varying ranges, from 0 meters outward greater than or equal to 400 meters in accordance with the power supplied to the disruption components 104. Accordingly, it will be appreciated by those skilled in the art that the maximum range of the portable countermeasure device 100 may be extended or reduced in accordance with the amount of power supplied to the disruption components 104, the ratio of power to time on target, and the like.

In operation, the soldier or law enforcement officer will target a drone hovering or flying in an unauthorized area by aiming the at least one antenna 122A-C of the portable

countermeasure device 100 in a manner similar to a regular firearm. That is, the soldier or law enforcement officer, using the at least one sight 124, directs the at least one antenna 122A-C of the portable countermeasure device 100 toward the drone. After ensuring that sufficient power is available, and the drone is within the effective range of the portable countermeasure device 100, the soldier or law enforcement officer activates the activator 110 to activate the control circuit (not shown), which regulates the power from a battery or other power source to the disruption components 104. In an alternative embodiment, a single activator (not shown) may control activation of all disruption components 104, thereupon simultaneously or sequentially generating disruptions signals as described herein when the activators 110 and 112 are activated. When disrupting multiple frequency bands, e.g., control signals, Wi-Fi and/or GNSS, multiple disruption signal generators 106 and amplifiers 108 are activated to produce the desired disruption signal, e.g., noise, spoofing, alternate commands, alternate coordinates, etc., on the selected frequency bands.

The disruptive signal is then directed through the at least one antenna 122A-C (capable of handling multiple frequency bands) or multiple antennae and transmitted toward the drone at which the portable countermeasure device 100 is aimed. The disruption cone 126 then extends outward from the portable countermeasure device 100 toward the drone, disrupting control and GNSS signals effectively negating the presence of the drone in the unauthorized area. Alternative embodiments disclosed herein include generating, via the signal generator 106, alternative commands to the drone, instructing the drone to land, change direction, change video broadcast stream, stop video streaming/recording, thereby overriding the original control signals. Furthermore, the portable countermeasure device 100 may be configured to transmit altered navigation coordinates, confusing the drone or forcing the drone to leave (or travel to) a particular area. The soldier or law enforcement officer then maintains his/her aim on the drone until the drone falls, retreats, loses power, or the like. The activator(s) 110-112 may then be deactivated by the law enforcement officer or soldier and the disabled drone may then be recovered by the appropriate authority for determination of the owner.

According to one example embodiment, the portable countermeasure device 100 includes hardware, software, and/or any suitable combination thereof, configured to interact with an associated operator, a networked device, networked storage, remote devices, detector systems, tracking systems, and the like. In such an example embodiment, the portable countermeasure device 100 may include a processor 101, which performs signal analysis, ballistic analysis, or the like, as well as execution of processing instructions which are stored in memory 103 connected to the processor 101 for determining appropriate signal generation for disruption, power supply management, and the like. Further, it will be understood that separate, integrated control circuitry, or the like, may be incorporated into the portable countermeasure device 100 so as to avoid interference of operations by the disruption components 104, or the like.

In some embodiments, the processor 101 is an internal microprocessor that is further configured to run internal self-monitoring operations. That is, the countermeasure device 100 includes internal components that verify that the system is operating correctly before radiating out a disruption signal to the at least one antenna 122A-C. The internal monitoring may occur at one of many points inside the RF chain (source-filtering-amplification-transmission). In some embodiments, the system verification is monitored between

amplification and transmission of a signal. When the signal is monitored between amplification and transmission, a high level of confidence of performance is achieved without an external capture device.

The internal self-monitoring is achieved by tapping off a small portion of the signal after amplification. That is, the frequency or frequencies generated by the at least one signal generator **106** and amplified by the corresponding at least one amplifier **108**, is measured by the processor **101** to ensure that the proper power level is in the right frequency band. Each transmitted frequency may be measured by the processor **101** simultaneously. In some embodiments, the wideband signal going to each antenna is measured to ensure there are no spurious transmissions out-of-band.

In accordance with the exemplary embodiment of FIG. 1, the countermeasure device **100** includes at least one temperature sensor **127** in communication with the processor **101** configured to measure a temperature at a desired location of the device. The at least one temperature sensor **127** may be variously embodied for example and without limitation as a thermistor, thermocouple, resistance temperature detector (RTD), and/or a combination thereof. In some embodiments, the at least one temperature sensor **127**, is placed within a reading distance to the amplifier **108**, such that an approximate temperature of the amplifier **108** may be measured. In other embodiments, the at least one temperature sensor **127** is placed in proximity to the replaceable battery **150**, such that an approximate temperature of the battery **150** may be measured.

In some embodiments, the processor **101** is configured to receive a temperature from the at least one temperature sensor **127**. If the received temperature is above a predetermined threshold temperature, the processor **101** may selectively remove power to the high temperature amplifier **108** or may power down the countermeasure device **100** entirely. In some embodiments, upon detection of a temperature greater than a predetermined threshold temperature, the processor **101** generates a haptic feedback pattern communicated by the haptic feedback component **121** and processor **101**, to inform the operator of the temperature issue. In some embodiments, the processor **101**, is configured to both send haptic feedback as described as well as remove power from the hot detected amplifier. In some embodiments, the processor **101** is further configured to record the measured temperatures of the countermeasure device **100** and store the temperature information in a data log described in greater detail below.

In some embodiments, the countermeasure device **100** includes a GNSS receiver **128** in communication with the processor **101** to monitor the geographic position of the device **100** and provide, change, or unlock features associated with a determined position. For example and without limitation, a geolocation of the countermeasure device **100** may be detected and the processor **101**, memory **103**, and associated software may load a particular device profile set for that particular geolocation. A particular device profile may include instructions executed by the processor **101** for the countermeasure device **100** to radiate a disruption signal at a particular power and/or at a predetermined frequency band. In this way, the countermeasure device **100** may automatically select a device profile associated with a particular power and frequency band based on a profile tied to a geolocation. In some embodiments, the processor **101** determining the geolocation of the device, may communicate to the operator via the haptic feedback component **121**, when the operator holding the countermeasure device **100**, enters or leaves a geographic location. For example, haptic

feedback may be provided to the operator upon entering or leaving defined enemy territory, restricted areas, or areas defined by geofencing. In some embodiments, the processor **101** is further configured to record the measured geolocation of the countermeasure device **100** and store the geolocation information in a data log described in greater detail below.

In some embodiments, the countermeasure device **100** includes a time module that counts the operational time of the countermeasure device **100**. The operational time may be stored and updated into the system memory **103** for example and without limitation, diagnostic and maintenance purposes. As an illustrative example, if a time count reaches a certain threshold (e.g., 10 hours), the countermeasure device **100** may communicate to the operator (via display **120** and/or haptic feedback **121**) that a maintenance is set to be performed. In some embodiments, the processor **101** is further configured to record the measured time counts of the countermeasure device **100** and store the time information in a data log described in greater detail below.

In some embodiments, the internal self-monitoring is performed continuously while radiating and reported back to the operator (e.g., via haptic feedback **121**). The data created during the internal self-monitoring may be logged and stored in the memory **103** for system performance analysis at a later time.

In some embodiments, the countermeasure device **100** includes internal components configured to log system performance. In accordance with such embodiments, the system performance information may correspond to machine state logs, which provide a capture of the state of the countermeasure device **100** at a particular point in time. For example, and without limitation, the machine state log may include the position of a trigger (e.g., activated/inactive), power level, internal switch position, length of trigger activation, selector switch position, and the like. It will be appreciated that other commonly recorded system operation information may be included herein, such as the configuration of the countermeasure device **100**, e.g., settings, power levels, switch positions, temperatures, etc., and the preceding listings are intended as nonlimiting examples thereof. The system performance information may be recorded to the internal memory **103** or to a portable memory (e.g., a micro-SD card). That is, the microprocessor board **105**, includes a receptacle (e.g., a memory card slot) configured to accept and read a portable memory inserted therein. In some embodiments, the memory card slot is located on the edge of the microprocessor board **105** closest to the antennas. In other embodiments, the memory card slot is located in the buttstock cavity **116** and accessible when opening the buttstock door **118**. In other embodiments, the memory card slot is located within the body **102**, requiring removal of a portion of the body for access. It is to be appreciated that the exemplary locations are for example purposes only and are not to be considered limiting.

According to another example embodiment, the portable countermeasure device **100** may include a selector control (**130** of FIG. **12A**), which may be located on the exterior of the portable countermeasure device **100** and easily accessible by the operator. Such a selector control may be operable to select a frequency or frequencies to be generated by the at least one signal generator and amplified by the corresponding at least one amplifier **108**. In accordance with one alternate embodiment, a variable amplifier may be used, whereupon power supplied to the signal generators **106** is modified, without increasing the power drain of the portable countermeasure device **100**. It will be appreciated that the selector control may be implemented to provide ease of use

to the soldier or law enforcement official in the field to reflect the desired target of the portable countermeasure device **100**.

In some embodiments, the portable counter measure device **100** includes a variable output attenuation feature. That is, the processor **101** controls the total outpower power of the countermeasure device **100**. The total output **103** power may be implemented by software instructions stored in the memory and executed by the processor **101**, or by hardware with an integrated processor or in communication with processor **101**. In some embodiments, the power is attenuated by Pulse-Width Modulation (PWM) or Pulse-Duration Modulation. In other embodiments, attenuation is achieved by voltage control of the at least one amplifier **108**. In yet still other embodiments, attenuation is achieved by source waveform control. In still further embodiments, attenuation is achieved via a variable voltage attenuator. Attenuating the signal reduces the effective range of the countermeasure device **100**. In some embodiments, the selector control **130** is in communication with the processor **101**. The selector control **130** may be manipulated by the operator to attenuate the output signal, e.g., via PWM.

Turning now to FIGS. **2A-3F**, therein are illustrated three-dimensional and line views of an example portable countermeasure device **200** utilizing a multi-antenna (**202**, **204**, and **206**) implementation of according to one embodiment of the subject disclosure. As shown in FIGS. **2A-3F**, the portable countermeasure device **200** instead of utilizing an existing firearm, utilizes a suitable dual-grip firearm-like form factor body **208** to which the various components are attached, e.g., custom rifle stock. The dual-grip form factor body **208** includes an attachment rail **212** for affixing optics, e.g., red dot sights, iron sights, holographic sights, or the like, as well as additional components. Suitable rails **212**, include, for example and without limitation, Picatinny, Weaver, NATO accessory rail, KeyMod, M-LOK, and the like. In this embodiment, the disruption components (not shown) are inserted within the dual-grip, firearm-like, form factor body **208** in place of the standard firearm components, e.g., the receiver(s) and barrel. This reduces the cost of implementation of the subject disclosure, while preserving the familiarity with a common weapon for the soldier and/or law enforcement personnel.

The multiple antennae **202**, **204**, and **206** illustrated in FIGS. **2A-3F**, are coupled to the body **208** adjacent a reflector **214**, which directs signals away from the operator and toward the target. The antennae **202**, **204**, and **206** may correspond, for example and without limitation, to a Yagi antenna, a proprietary double helical antenna, an LPA, and/or various combinations thereof, depending upon the frequencies being targeted by the portable countermeasure device **200**. The body **206** further includes a buttstock section **210** incorporating a connector **117B**, as discussed supra. In addition to the foregoing, the body **208** of the portable countermeasure device **200** illustrated in FIGS. **2A-3F** utilizes the above-mentioned dual-grips **114** and **115**. It will be appreciated that the configuration of the first grip **114** angled toward the buttstock **210** and the second grip **115** angled toward the antennae **202**, **204**, and **206** allow the operator to easily control and aim the device **200** towards an intended target. As shown, the second grip **115** extends downward from the trigger guard of the first trigger **110** and allows an operator easy access to the second trigger **112**, without requiring the operator to adjust his/her grip on the device **200**. Also depicted in FIGS. **2A-3F** is a selector switch **216**, optionally included to allow for the operator to select which frequency or frequencies to be jammed by the

portable countermeasure device **200**. That is, according to one embodiment, the selector **216** is communicatively coupled to the internal disruptor components **104** of the portable countermeasure device **200**, allowing the operator to enable jamming of one or more frequencies. FIGS. **6A**, **6B**, and **6C** provide three-dimensional depictions illustrating varying embodiments of the portable countermeasure device **200**, including the aforementioned dual-grips **114** and **115**.

As illustrated in FIGS. **6A-6C**, the portable countermeasure device **200** may utilize varying embodiments of the antenna **206**, as shown therein. In particular, the antenna **206** is representative of a Yagi antenna, suitably configured, in one embodiment, to transmit signals in the 400-500 MHz range, with particular emphasis on the 433 MHz frequency. The antenna **206**, as shown in FIGS. **6A-6C** is capable of implementation using a variety of shields, protecting the antenna from damage during transport and use. A more detailed illustration of one embodiment of the antenna **206** is shown in the three-dimensional views of FIGS. **7A-7E**, and the line drawings of FIGS. **8A-8E**.

It will be appreciated that the embodiment of FIGS. **2A-3F**, and FIGS. **6A-6C** utilizes disruption components **104** located within the body **208** of the portable countermeasure device **200**. However, in an alternate embodiment, as depicted in FIGS. **4** and **5**, the disruption components **104** may be removably coupled via connector **117B** to the portable countermeasure device **200** externally, as shown.

The portable countermeasure device **200** of FIGS. **2A-3F** utilizes dual grips **114** and **115** with corresponding dual activators **110** and **112** for respective disruption of control signals and GPS/navigation signals. FIGS. **9A** and **9B** provide close-up views of an example implementation of the dual grips **114** and **115** with associated dual activators **110** and **112** on the portable countermeasure device **200**. The rendering in FIGS. **9A-9B** further illustrate the dual grips **114** and **115** of the portable countermeasure device **200**. As shown, the first grip **114** is configured to enable the operator to engage the first trigger **110**. The cantilevered or forward-angled second grip **115** is configured to enable the operator to engage the second trigger **112**, without requiring the operator to adjust his stance or wielding of the device **200**, i.e., the operator does not have to move his hands from the grips **114** or **115** in order to engage the disruption components **104**. In accordance with one embodiment, the portable countermeasure device **200** may be modular, rugged, and portable, capable of being transported by a soldier or law enforcement official without damage to the antenna **202-206**, the body **208**, optics, rail attachments, etc., may be disassembled and stored in the backpack depicted in FIG. **5**.

FIGS. **10A-10F** provide a three-dimensional view of the body **208** of the portable countermeasure device **200** in accordance with one embodiment of the subject application. FIGS. **11A-11F** provide a further detailed line view of the body **208** of the portable countermeasure device **200** in accordance with the embodiment of FIGS. **10A-10F**. As will be appreciated, the body **208**, comprising the dual grips **114** and **115**, buttstock **203**, rails **212**, dual-triggers **110-112**, and connection **117B** is illustrated without the reflector **214**, or antennae **202-206**. Accordingly, the body **208** comprising the above-identified components, as illustrated in FIGS. **10A-11F** is capable of adaptation to a plurality of weapons, including, for example and without limitation, low-recoil ballistic weapons, directed energy weapons, and the like. It will be understood that the example implementations of FIGS. **1-11F** are non-limiting examples of possible firearm-

like form factors implemented as the portable countermeasure device **100** according to the disclosures contained herein.

FIGS. **12A-12G** provide a three-dimensional view of the body **102** of the portable countermeasure device **100** of the exemplary embodiment of FIG. **1**. The exemplary embodiment of FIGS. **12A-12G** illustrate a single trigger **110** system, at least one antenna **122A-C** and buttstock **113**, with a buttstock cavity enclosed by buttstock door **118**.

As explained above, in some embodiments disclosed herein, the countermeasure device **100**, includes a plate **123** with at least one antenna attached thereto. The plate **123** is removable from the body **102** of the countermeasure device **100** and allows for another similarly shaped plate to removably connect thereto in order to switch antenna of the countermeasure device **100** (in case the first set of antennae are damaged). In some embodiments, the countermeasure device **100** includes at least one removable side panel **125A**, **125B**. The at least one removable side panel **125** may be attached to the body **102** by at least one fastener. In some embodiments, the at least one removable side panel **125** is secured to the body **102** via a locking fastener **129**. Unlocking the locking fastener **129** and removing the at least one removable side panel **125** provides access to the internal components shown in the cross section of FIG. **1**. In some embodiments, upon removal of the at least one removable side panel **125**, the operator has access to at least one fastener for securing the plate **123** to the body **102**. It is to be appreciated that each the left and right side may include a removable side panel, and that one or both panels may each be secured to the body **102** via separate fasteners. Furthermore, either panel or both panels may be removed to provide access to the internal components (e.g., amplifies **108**, signal source **106**, etc.).

FIGS. **13A-13C** provide a three-dimensional view of a buttstock **113** accordance with one embodiment of the subject application. FIG. **13A** illustrates the buttstock **113** in an open position. That is, the buttstock door **118** is pivoted about the hinge **119** such that access to the buttstock cavity **116** is provided. Also illustrated is coupling **117A** configured to engage a corresponding connector **152** associated with a power source, such as replaceable battery **150**. For example and without limitation, the coupling **117A** may include a plurality of pins **1171** (six pins are illustrated). The replaceable battery **150**, likewise may include a corresponding connector **152** having a plurality of apertures **1521** each configured to receive and electronically connect to a pin **1171** of coupling **117A**. As illustrated in FIG. **13B**, the replaceable battery **150** may be inserted into the buttstock cavity **116**, such that the coupling **117A** engages the battery connector **152**, providing electrical power to the countermeasure device **100**. In some embodiments and with continued reference to FIGS. **13A-13C**, the buttstock **113** includes a buttstock fastener **132**. The buttstock fastener **132** is configured to secure the buttstock door **118** in a closed position such that the buttstock door does not unexpectedly open allowing the contents of the buttstock cavity **116** to fall out. In some embodiments, the buttstock fastener **132** is configured to engage a fastener structure **133** located on a top portion of the buttstock **113**. As illustrated in FIG. **13A-C** the buttstock fastener **132** includes a spring clip **134**. When the buttstock door **118** is in the closed position, the spring clip **134** of the fastener **132** may engage a catch structure **133** such that the buttstock door **118** is urged into a secure closed position.

It is to be appreciated that in connection with the particular illustrative embodiments presented herein certain struc-

tural and/or function features are described as being incorporated in defined elements and/or components. However, it is contemplated that these features may, to the same or similar benefit, also likewise be incorporated in other elements and/or components where appropriate. It is also to be appreciated that different aspects of the exemplary embodiments may be selectively employed as appropriate to achieve other alternate embodiments suited for desired applications, the other alternate embodiments thereby realizing the respective advantages of the aspects incorporated therein.

It is also to be appreciated that particular elements or components described herein may have their functionality suitably implemented via hardware, software, firmware or a combination thereof. Additionally, it is to be appreciated that certain elements described herein as incorporated together may under suitable circumstances be stand-alone elements or otherwise divided. Similarly, a plurality of particular functions described as being carried out by one particular element may be carried out by a plurality of distinct elements acting independently to carry out individual functions, or certain individual functions may be split-up and carried out by a plurality of distinct elements acting in concert. Alternately, some elements or components otherwise described and/or shown herein as distinct from one another may be physically or functionally combined where appropriate.

In short, the present specification has been set forth with reference to preferred embodiments. Obviously, modifications and alterations will occur to others upon reading and understanding the present specification. It is intended that the invention be construed as including all such modifications and alterations insofar as they come within the scope of the appended claims or the equivalents thereof. That is to say, it will be appreciated that various of the above-disclosed and other features and functions, or alternatives thereof, may be desirably combined into many other different systems or applications, and also that various presently unforeseen or unanticipated alternatives, modifications, variations or improvements therein may be subsequently made by those skilled in the art which are similarly intended to be encompassed by the following claims.

What is claimed is:

1. A dual-grip portable countermeasure device, comprising:
 - a body, the body including a first grip and a second grip, the second grip adjacent the first grip located on a bottom portion of the body;
 - at least one directional antenna coupled to a front of the body; and
 - a processor and memory in communication therewith wherein the memory stores instructions which are executed by the processor to monitor a system performance by measuring at least one performance indicator of the countermeasure device.
2. The dual-grip portable countermeasure device of claim **1**, further comprising a haptic feedback component in communication with the processor configured to generate a haptic feedback pattern associated with the measured performance indicator.
3. The dual-grip portable countermeasure device of claim **1**, wherein the measured performance indicator is at least one of a temperature, a machine state, a battery power level, a transmission signal, a GNSS position, a time count, and an output power level.

21

4. The dual-grip portable countermeasure device of claim 3, wherein the measured performance indicator is recorded to a data log within the memory.

5. The dual-grip portable countermeasure device of claim 3, wherein the measured performance indicator is recorded to a data log of a removable data storage device.

6. The dual-grip portable countermeasure device of claim 5, wherein the removable data storage device is one of an SD card, micro-SD card, mini-SD card and flash drive.

7. The dual-grip portable countermeasure device of claim 4, further comprising at least one of a GNSS receiver or a temperature sensor in communication with the processor.

8. The dual-grip portable countermeasure device of claim 1, wherein the at least one signal disruption component further comprises:

- at least one signal generator; and
- at least one amplifier coupled to the at least one signal generator, wherein the at least one signal generator is configured to generate a disruptive signal on an associated frequency band and the corresponding at least one amplifier amplifies the generated disruptive signal, wherein the amplified disruptive signal is transmitted by at least one at least one directional antenna at an output power.

9. The dual-grip portable countermeasure device of claim 8, wherein the at least one disruption component generates disruption signals in at least one of the 72 MHz frequency band, the 433 MHz frequency band, the 800 MHz frequency band, the 915 MHz frequency band, the 1.2 GHz frequency band, the 1.3 GHz frequency band, the 1.5 GHz frequency band, the 2.4 GHz frequency band, or the 5.8 GHz frequency band.

10. The dual-grip portable countermeasure device of claim 8, wherein the processor is configured to attenuate the output power of the amplified disruptive signal.

11. The dual-grip portable countermeasure device of claim 10, wherein the processor attenuates the output power of the amplified signal by one of pulse width modulation, voltage control of the at least one amplifier, a variable voltage attenuator, and waveform control.

12. The dual-grip portable countermeasure device of claim 8, wherein the disruption signals including at least one of noise, spoofing, or alternate control commands are stored within the memory.

13. The dual-grip portable countermeasure device of claim 8, wherein the at least one directional antenna is affixed to a removable plate removably attached to a front portion of the body.

14. The dual-grip portable countermeasure device of claim 1, wherein the at least one directional antenna is selected from the group consisting of a helical antenna, a Yagi antenna, a spiral antenna, a conical antenna, a patch antenna, a phased array antenna, an LPDA antenna, or a parabolic antenna.

15. The dual-grip portable countermeasure device of claim 1, further comprising a buttstock comprising a buttstock cavity configured to receive a power supply.

22

16. A dual-grip portable countermeasure device, comprising:

- a body, the body including:
 - a processor and memory in communication therewith wherein the memory stores instructions which are executed by the processor to operate the countermeasure device;
 - a first grip located on a bottom portion of the body,
 - a second grip, the second grip adjacent the first grip located on the bottom portion of the body, and
 - a buttstock formed on a rear portion of the body, wherein the first grip is angled toward a buttstock of the body, and wherein the second grip is angled opposite the first grip toward the front of the body;
 - a buttstock cavity formed within the buttstock configured to receive a power supply, and
 - a plurality of disruption components located within the body, the disruption components configured to generate a plurality of disruption signals on a corresponding plurality of associated frequency bands.

17. The dual-grip portable countermeasure device of claim 16, wherein the memory stores instructions which are executed by the processor to monitor a system performance by measuring at least one performance indicator of the countermeasure device.

18. The dual-grip portable countermeasure device of claim 17, further comprising a haptic feedback component in communication with the processor is configured to generate a haptic feedback pattern associated with the measured performance indicator.

19. The dual-grip portable countermeasure device of claim 17, wherein a measured performance indicator is at least one of a temperature, a battery power level, a transmission signal, a GNSS position, a time count, and an output power level, wherein the countermeasure device further comprises at least one of a temperature sensor or GNSS receiver in communication with the processor configured to detect a temperature and position, respectively, of the countermeasure device.

20. The dual-grip portable countermeasure device of claim 16, further comprising:

- at least one activator coupled to the body adjacent at least one of the first grip or the second grip, the at least one activator in operable communication with at least one of the plurality of disruption components; and
- a plurality of directional antennae in communication with the plurality of disruption components, the plurality of directional antennae configured to emit a corresponding plurality of disruption signals generated by the plurality of disruption components at an output power.

21. The dual-grip portable countermeasure device of claim 20, further comprising a removable plate removably connected to a front portion of the countermeasure device, wherein the plurality of directional antenna is mounted to the removable plate.

22. The dual-grip portable countermeasure device of claim 19, wherein the processor is further configured to attenuate the output power by one of pulse width modulation, voltage control of the at least one amplifier, a variable voltage attenuator, and waveform control.

* * * * *