



US009085355B2

(12) **United States Patent**
DeLorean

(10) **Patent No.:** **US 9,085,355 B2**
(45) **Date of Patent:** **Jul. 21, 2015**

(54) **VERTICAL TAKEOFF AND LANDING AIRCRAFT**

(71) Applicant: **DeLorean Aerospace, LLC**, Bloomfield Hills, MI (US)

(72) Inventor: **Paul J. DeLorean**, Bloomfield Hills, MI (US)

(73) Assignee: **DeLorean Aerospace, LLC**, Bloomfield Hills, MI (US)

(*) Notice: Subject to any disclaimer, the term of this patent is extended or adjusted under 35 U.S.C. 154(b) by 147 days.

6,708,920 B2	3/2004	Fukuyama	
6,742,741 B1 *	6/2004	Rivoli	244/12.1
6,886,776 B2	5/2005	Wagner et al.	
6,966,174 B2	11/2005	Paul	
7,188,803 B2 *	3/2007	Ishiba	244/23 R
7,249,732 B2	7/2007	Sanders, Jr. et al.	
2005/0151003 A1	7/2005	Churchman	
2006/0226281 A1 *	10/2006	Walton	244/17.23
2009/0261209 A1	10/2009	Mioduchevski	
2010/0012790 A1	1/2010	Bostan	
2010/0051740 A1	3/2010	Yoeli	
2010/0270419 A1 *	10/2010	Yoeli	244/12.1
2010/0301168 A1 *	12/2010	Raposo	244/171.2

(Continued)

FOREIGN PATENT DOCUMENTS

WO WO0005131 A1 2/2000

(21) Appl. No.: **13/708,612**

(22) Filed: **Dec. 7, 2012**

(65) **Prior Publication Data**

US 2014/0158816 A1 Jun. 12, 2014

(51) **Int. Cl.**

B64C 29/00 (2006.01)

B64C 39/04 (2006.01)

B64C 39/10 (2006.01)

B64C 39/12 (2006.01)

(52) **U.S. Cl.**

CPC **B64C 29/0033** (2013.01); **B64C 39/04** (2013.01); **B64C 39/10** (2013.01); **B64C 39/12** (2013.01); **Y02T 50/12** (2013.01)

(58) **Field of Classification Search**

CPC B64C 29/0033
USPC 244/6, 12.1, 12.4, 23 R, 23 A, 56, 73 R
See application file for complete search history.

(56) **References Cited**

U.S. PATENT DOCUMENTS

4,537,372 A	8/1985	Forizs
5,383,627 A	1/1995	Bundo
5,890,441 A	4/1999	Swinson et al.
6,568,630 B2	5/2003	Yoeli

OTHER PUBLICATIONS

PCT Search Report and Written Opinion mailed Aug. 22, 2014 for PCT application No. PCT/US13/71531, 13 pages.

Primary Examiner — Philip J Bonzell

Assistant Examiner — Nicholas McFall

(74) *Attorney, Agent, or Firm* — Lee & Hayes, PLLC

(57) **ABSTRACT**

The disclosure generally pertains to a vertical take-off and landing (VTOL) aircraft comprising a fuselage and at least one fixed wing. The aircraft may include at least two powered rotors located generally along a longitudinal axis of the fuselage. The rotor units may be coupled to the fuselage via a rotating chassis, which allows the rotors to provide directed thrust by movement of the rotor units about at least one axis. By moving the rotor units, the aircraft can transition from a hover mode to a transition mode and then to a forward flight mode and back.

17 Claims, 30 Drawing Sheets

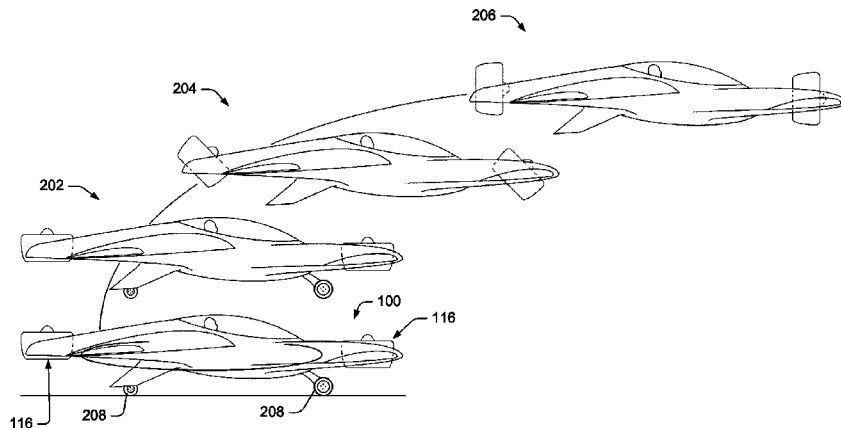

US 9,085,355 B2

Page 2

(56)

References Cited

U.S. PATENT DOCUMENTS

2012/0012692	A1	1/2012	Kroo	
2012/0091257	A1*	4/2012	Wolff et al.	244/12.4
2012/0298793	A1*	11/2012	Weddendorf et al.	244/17.23
2011/0190965	A1	8/2011	Hirvonen et al.	
2011/0226892	A1*	9/2011	Crowther et al.	244/17.23

* cited by examiner

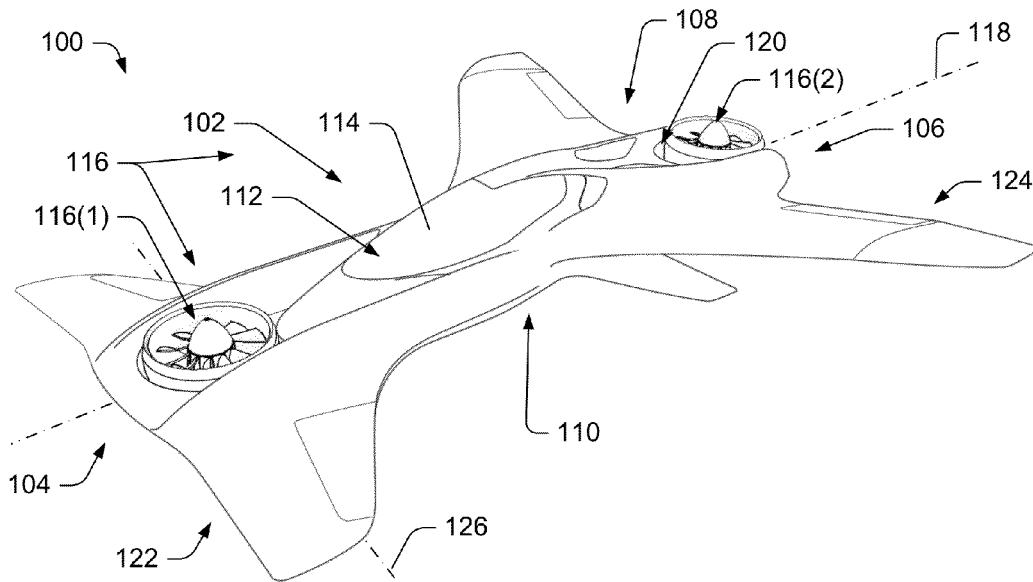

FIG. 1A

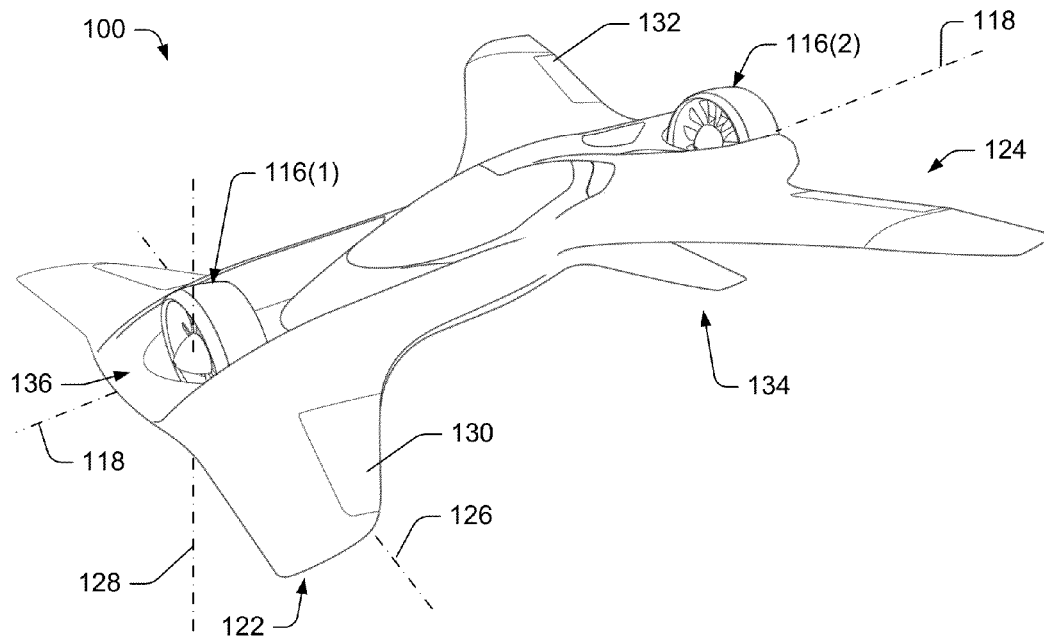

FIG. 1B

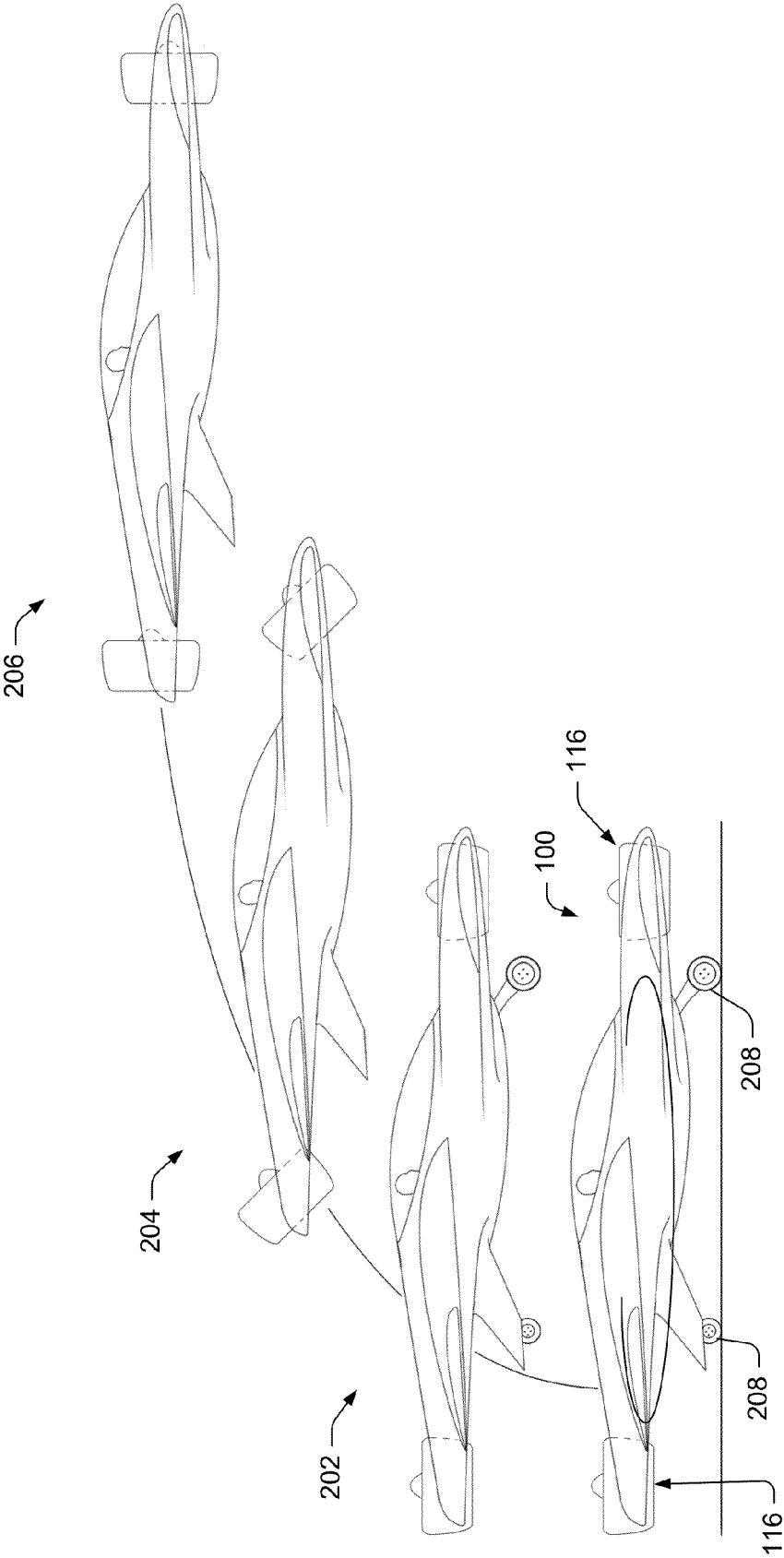

FIG. 2

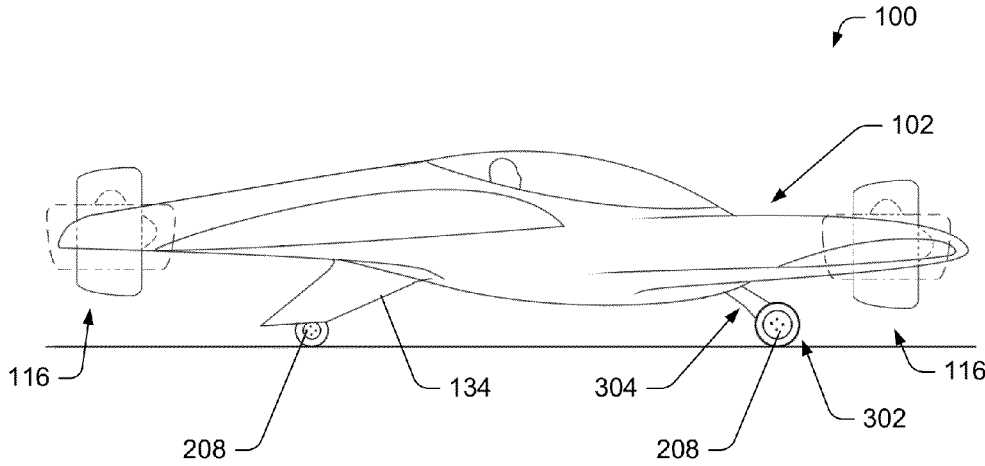

FIG. 3A

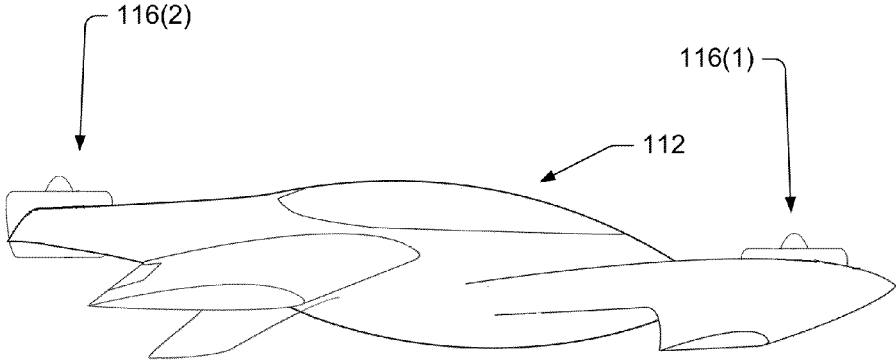

FIG. 3B

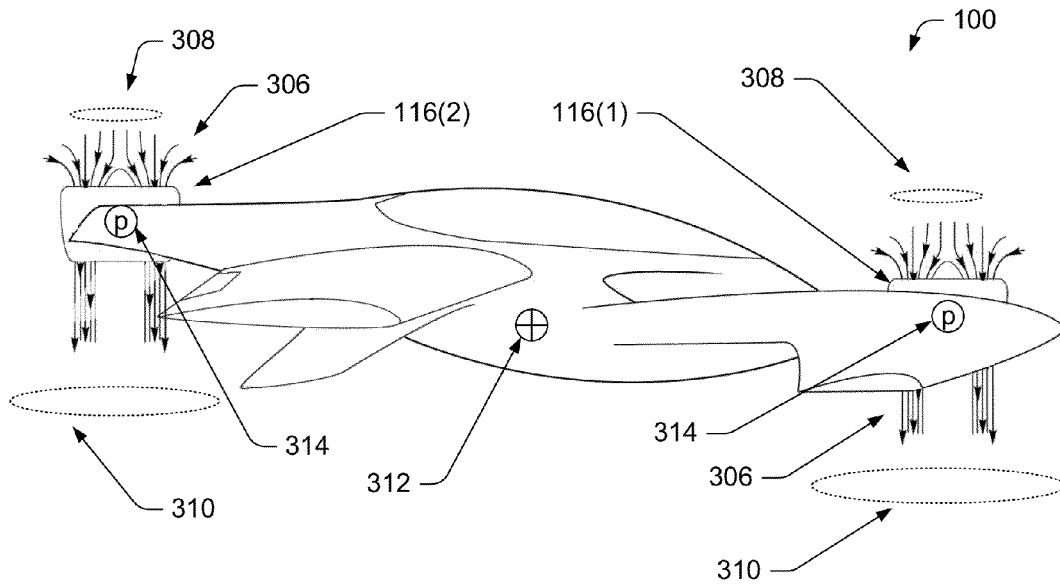

FIG. 3C

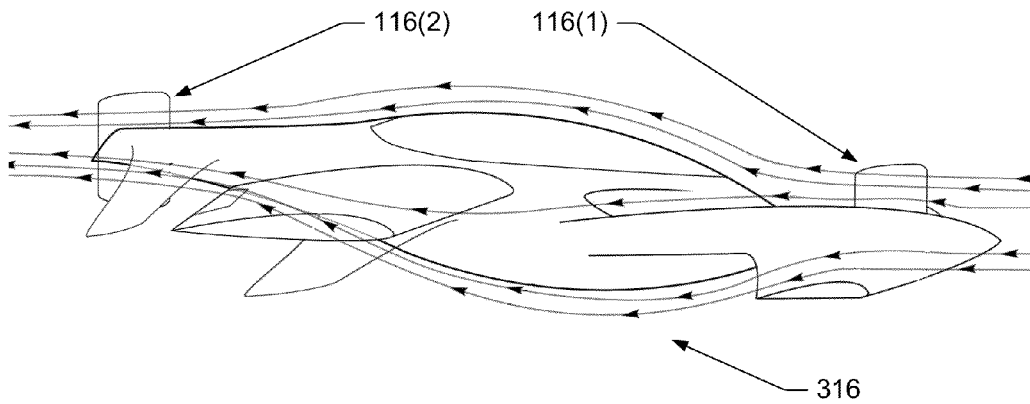

FIG. 3(b)

FIG. 3D

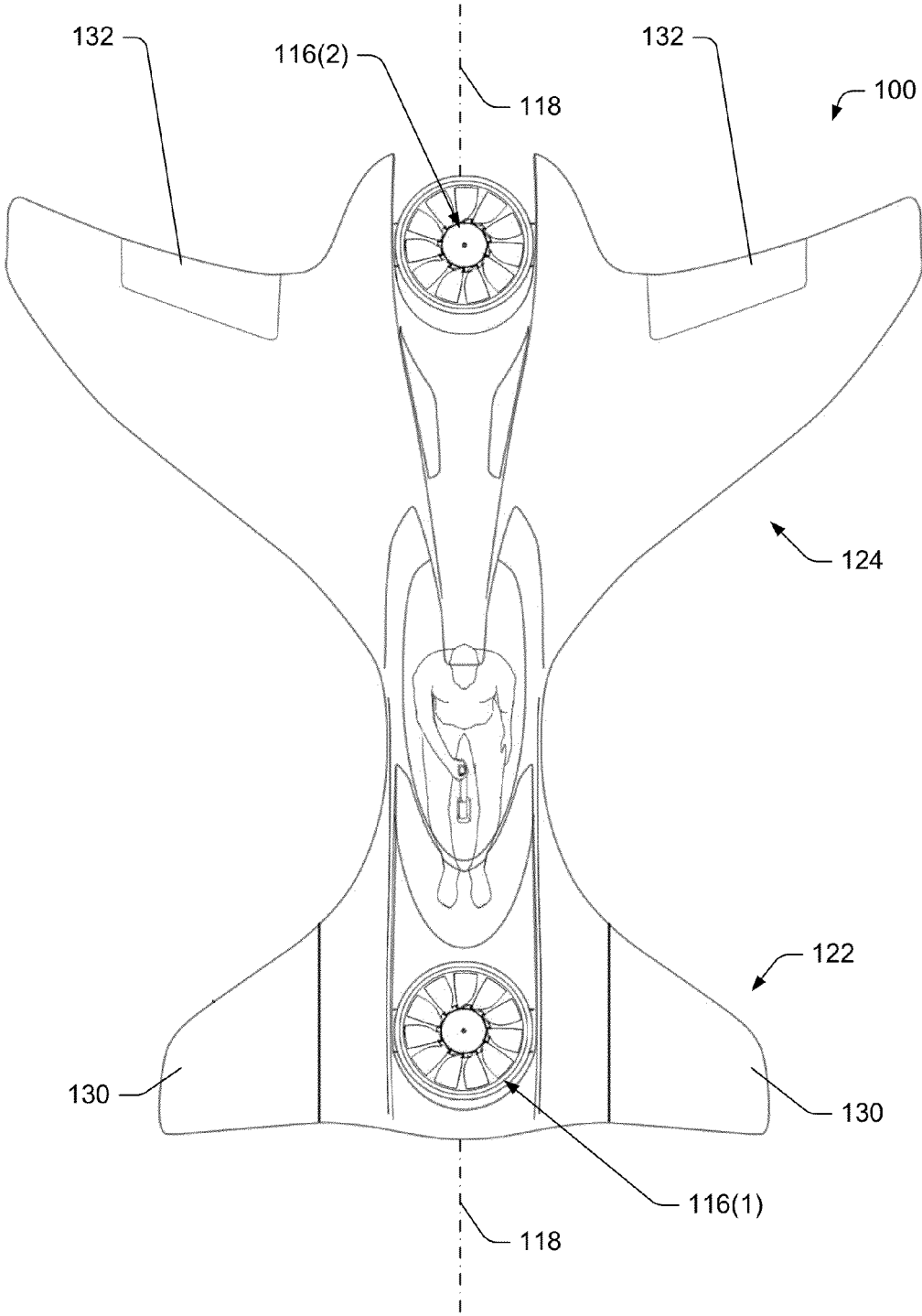

FIG. 4

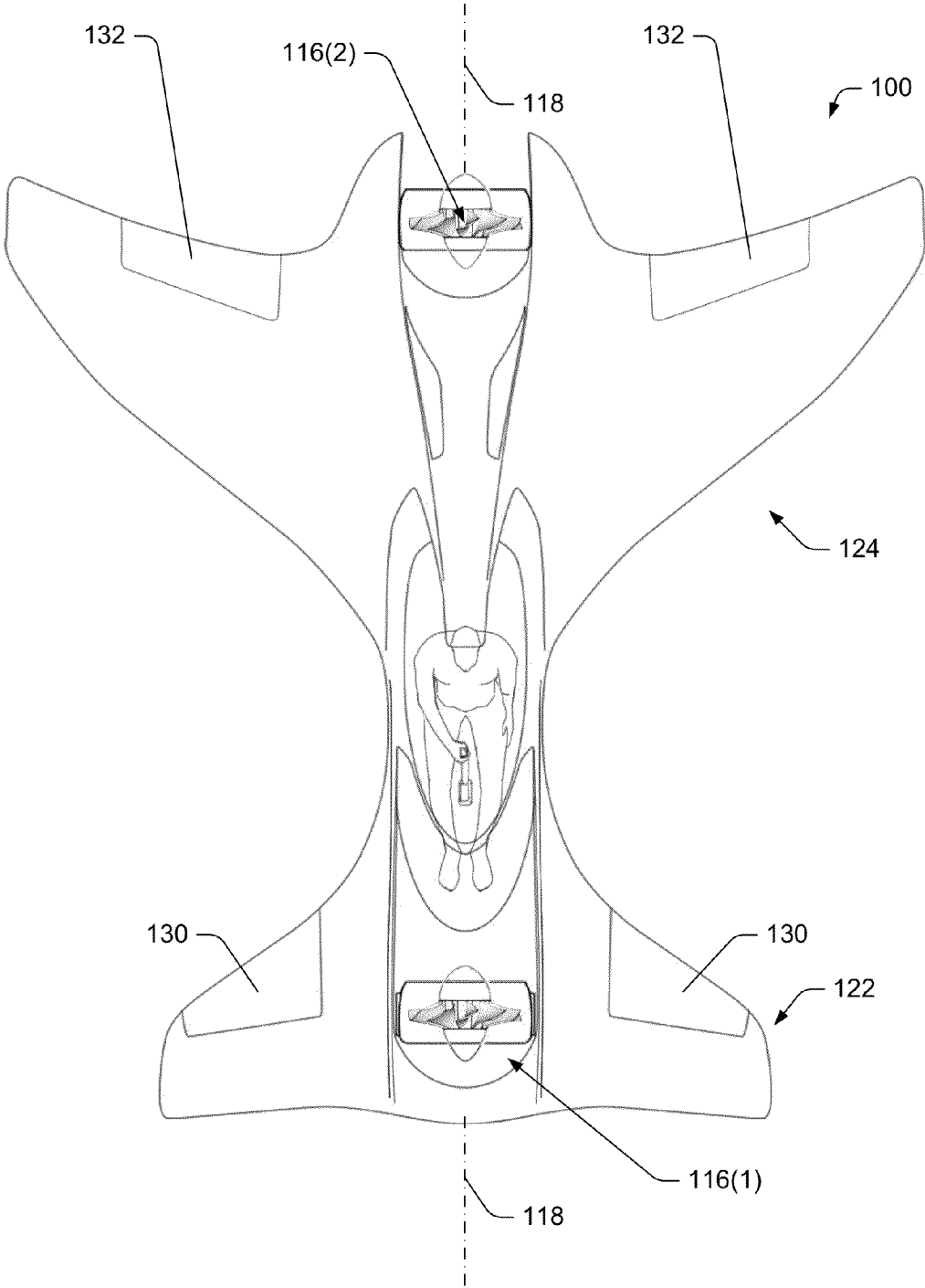

FIG. 5

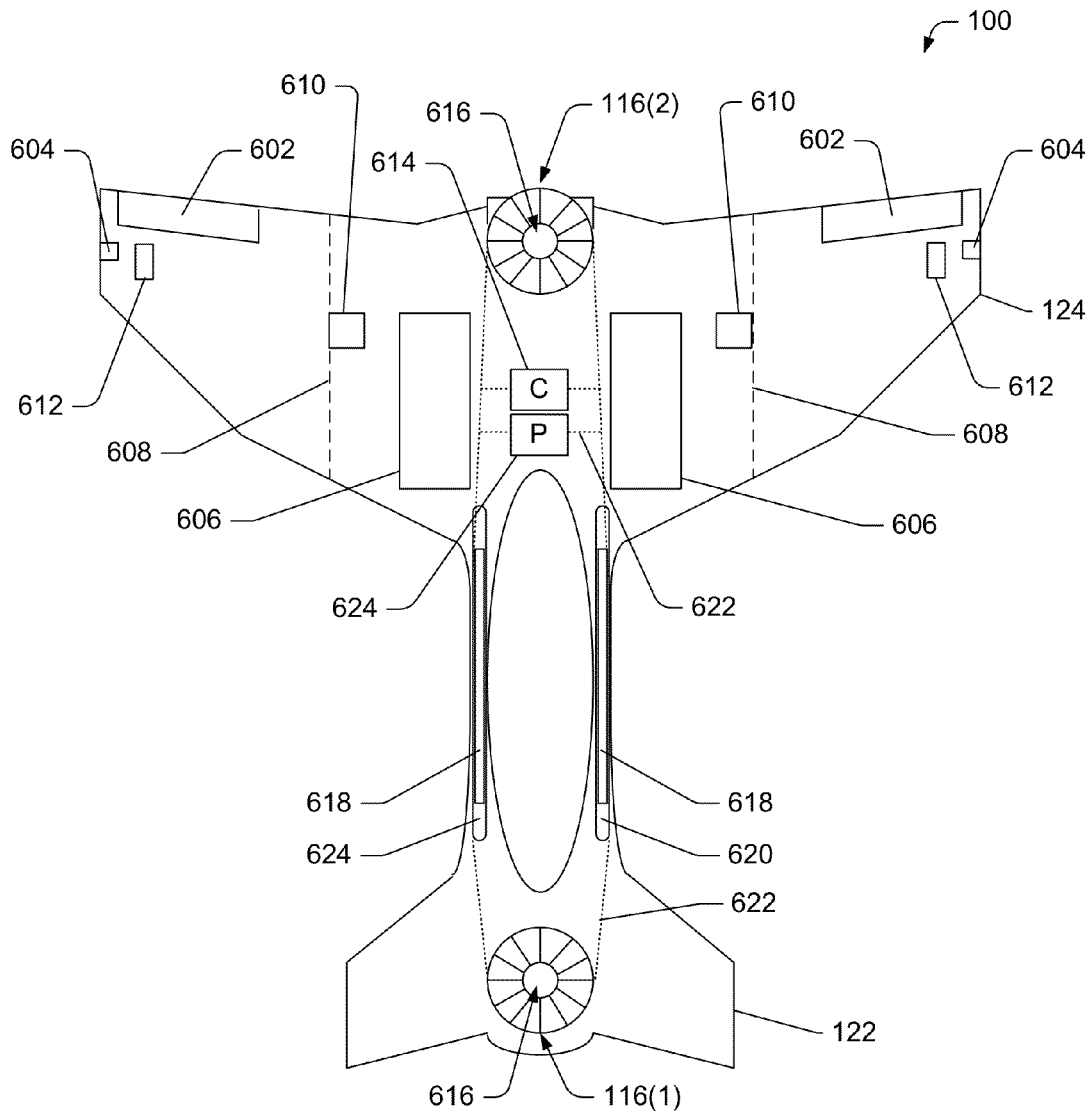

FIG. 6A

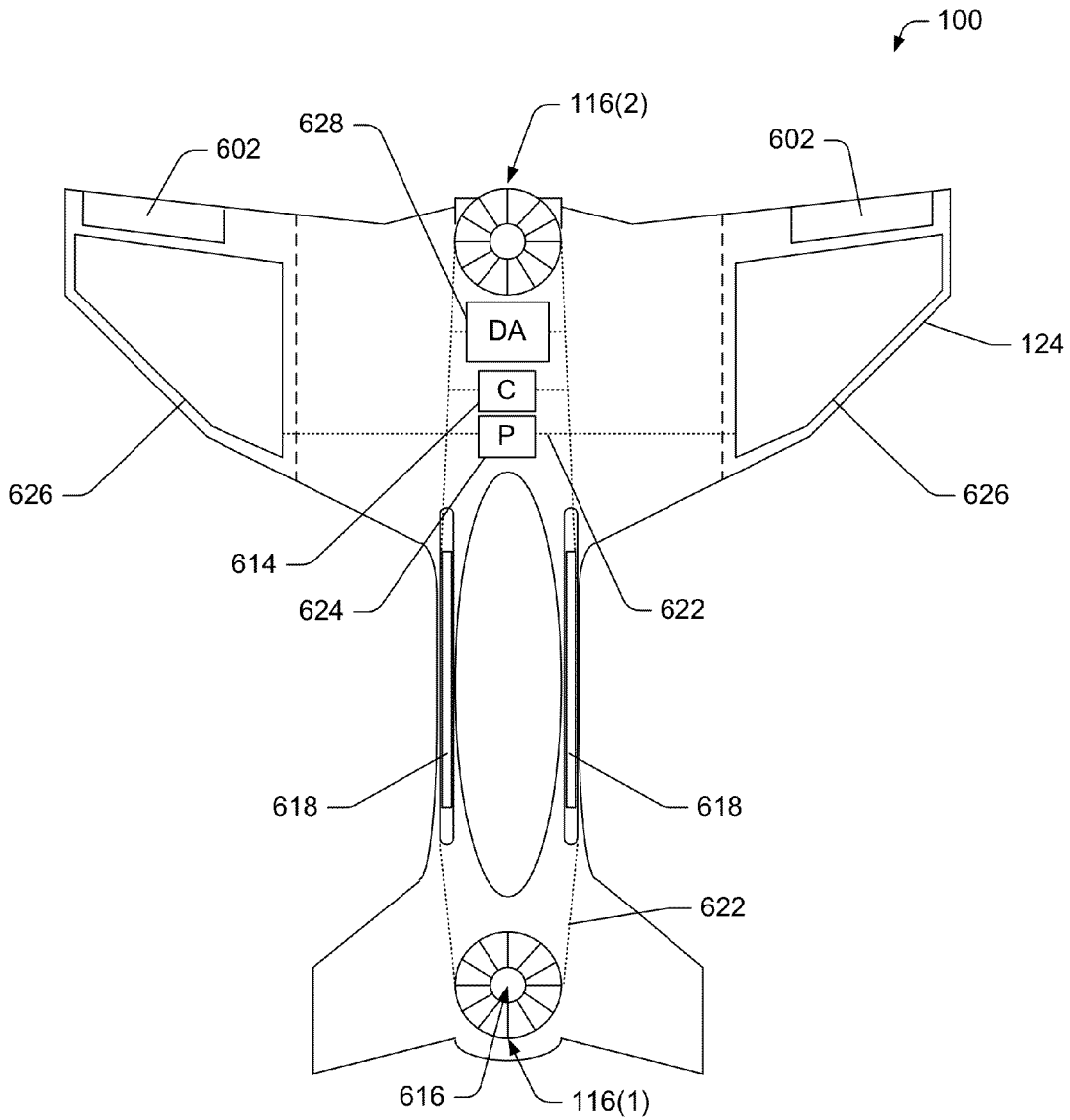

FIG. 6B

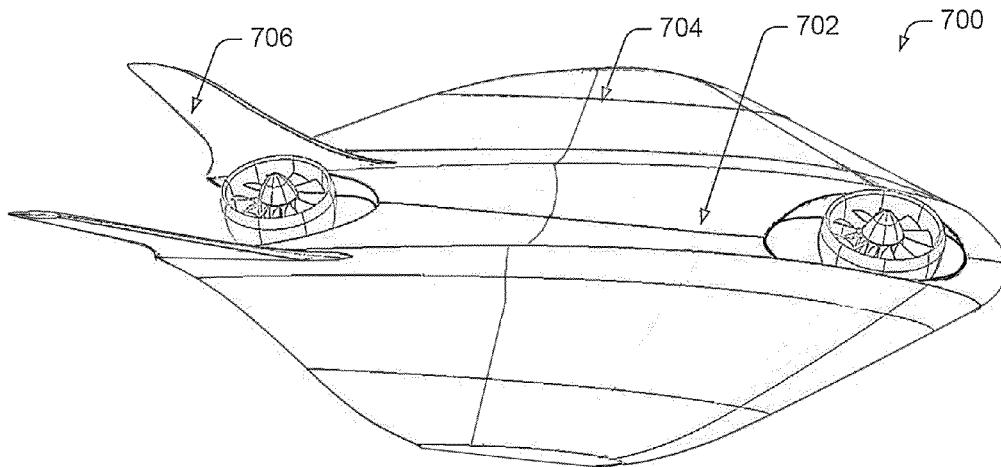

FIG. 7

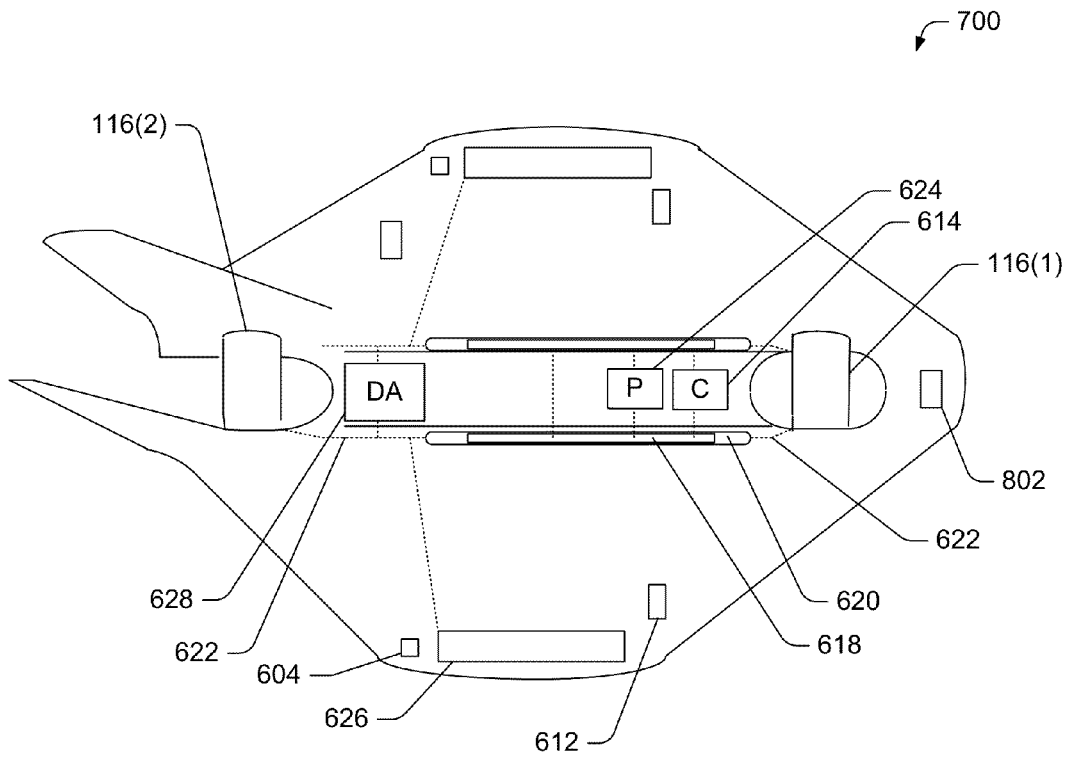

FIG. 8

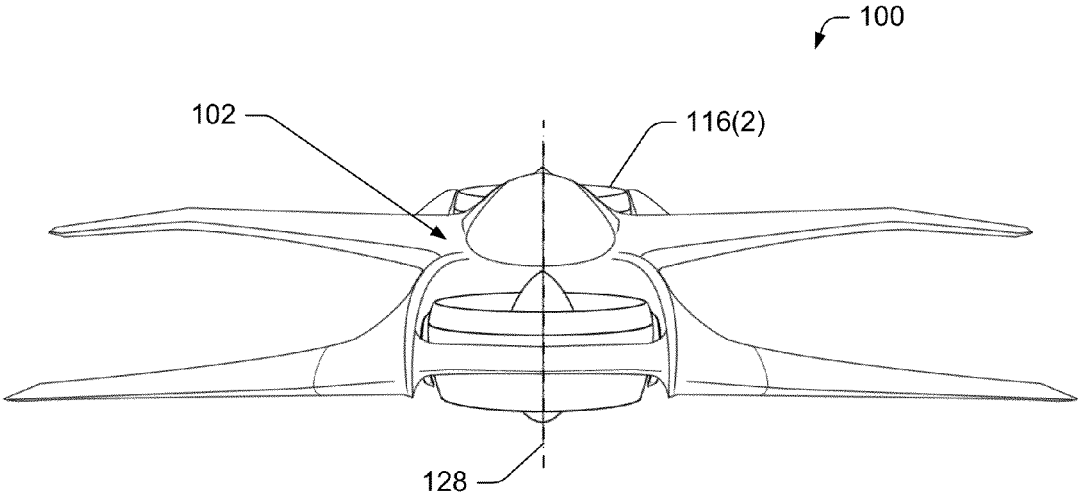

FIG. 9A

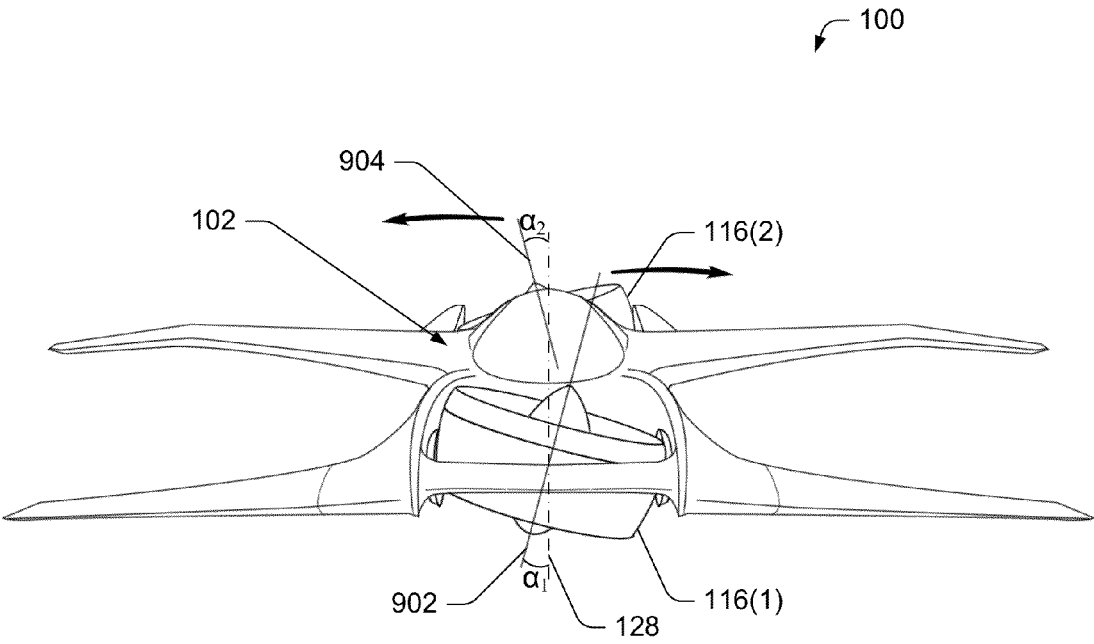

FIG. 9B

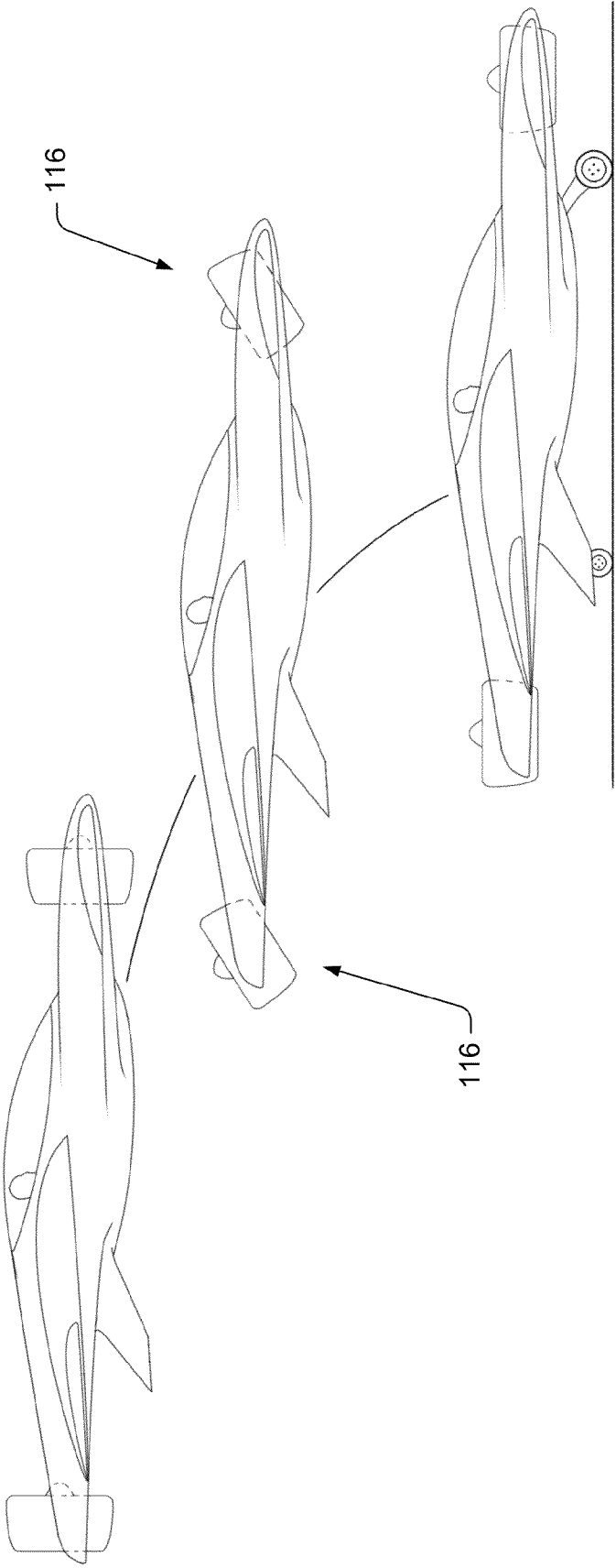

FIG. 9C

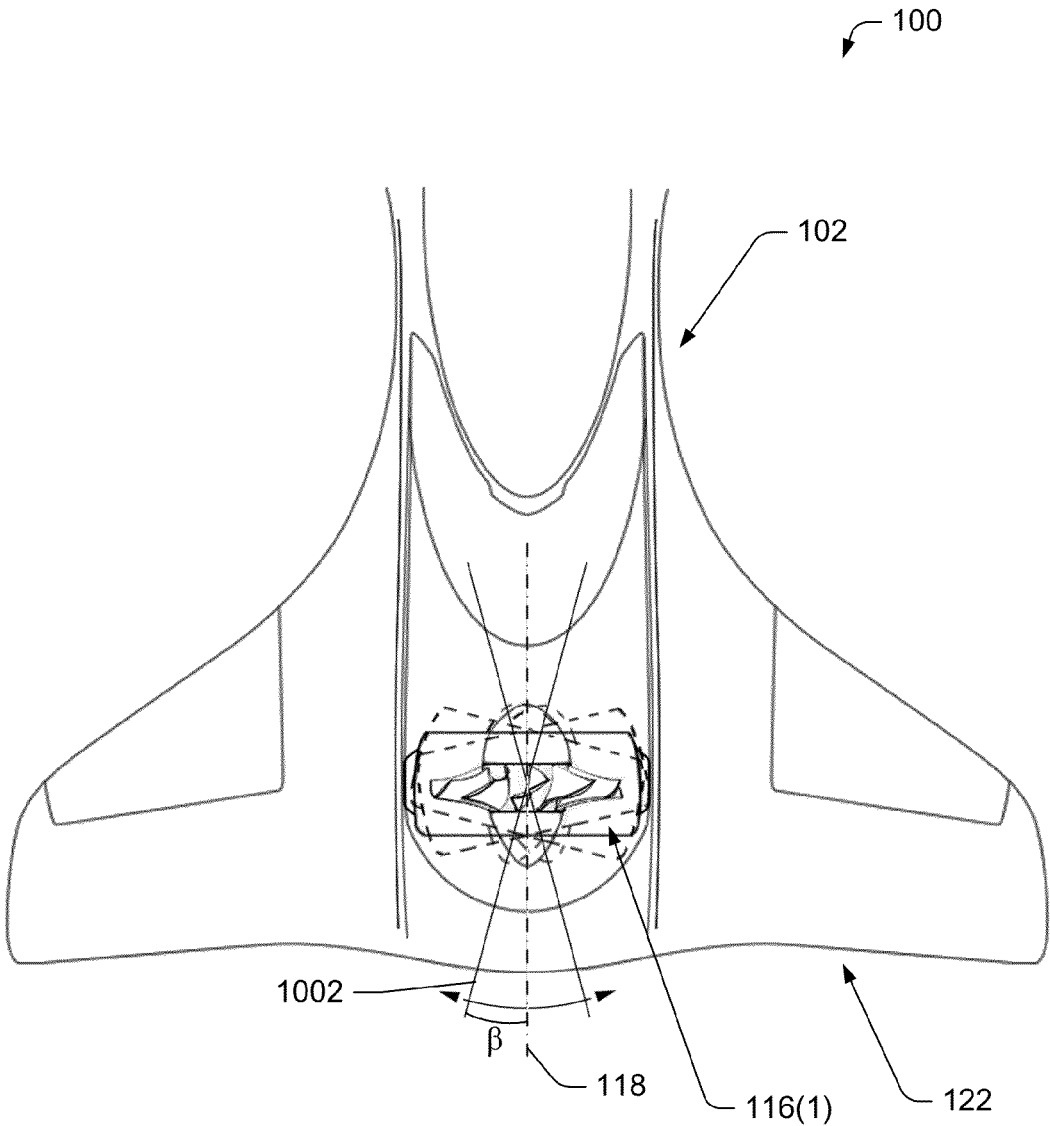

FIG. 10

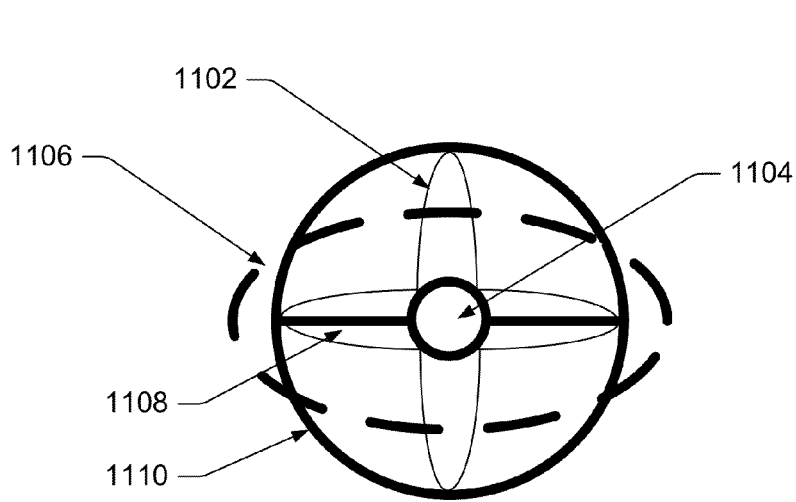

FIG. 11A

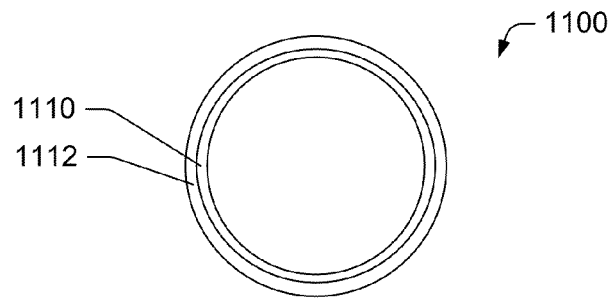

FIG. 11B

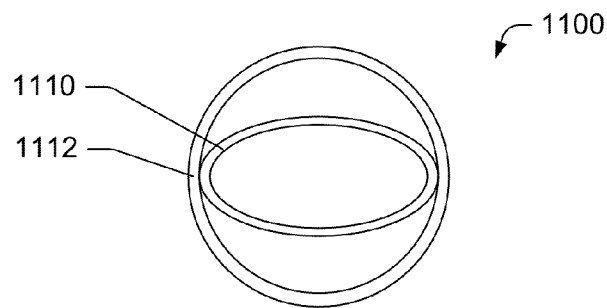

FIG. 11C

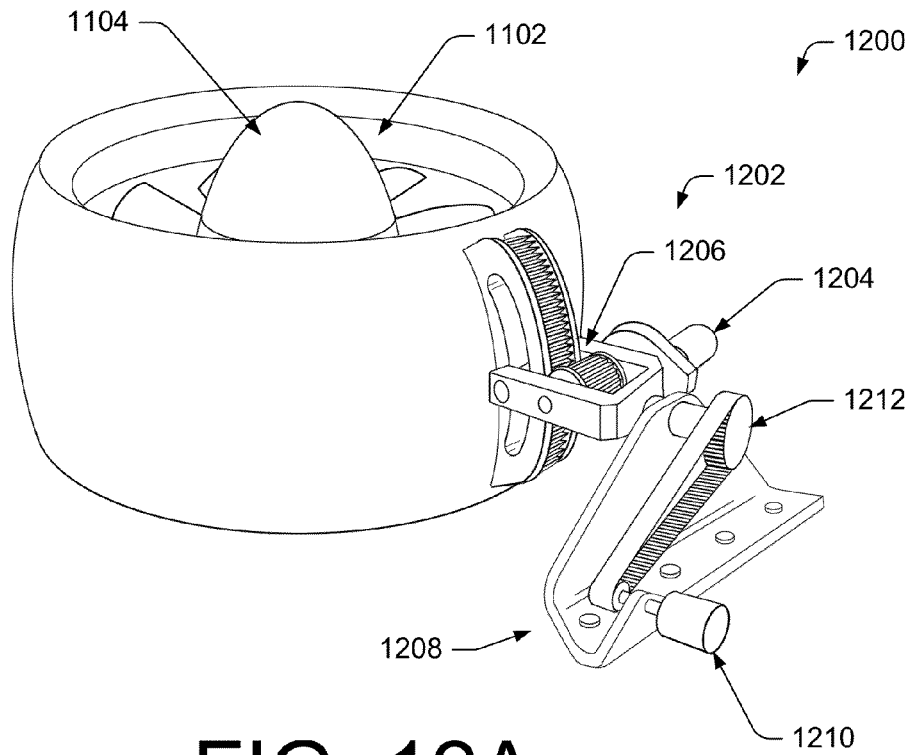

FIG. 12A

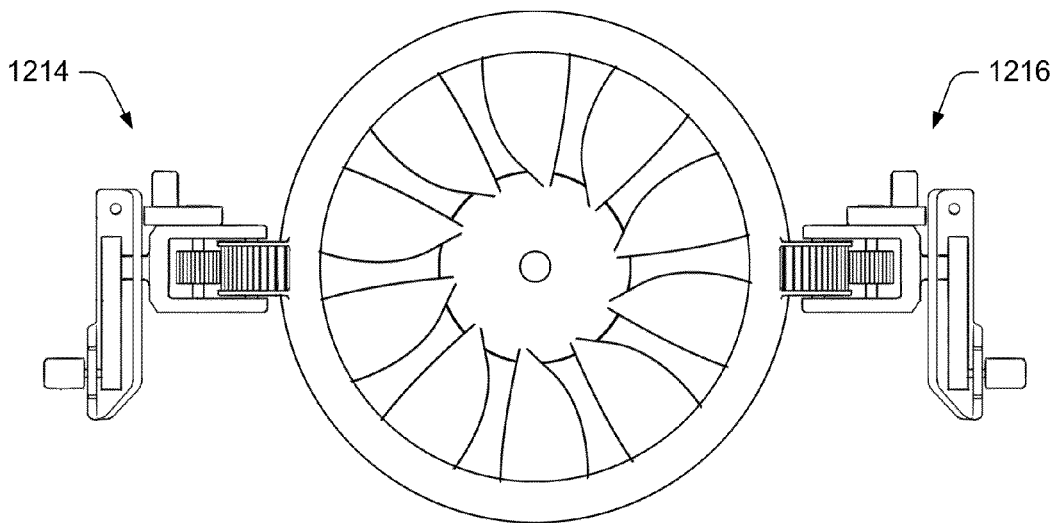

FIG. 12B

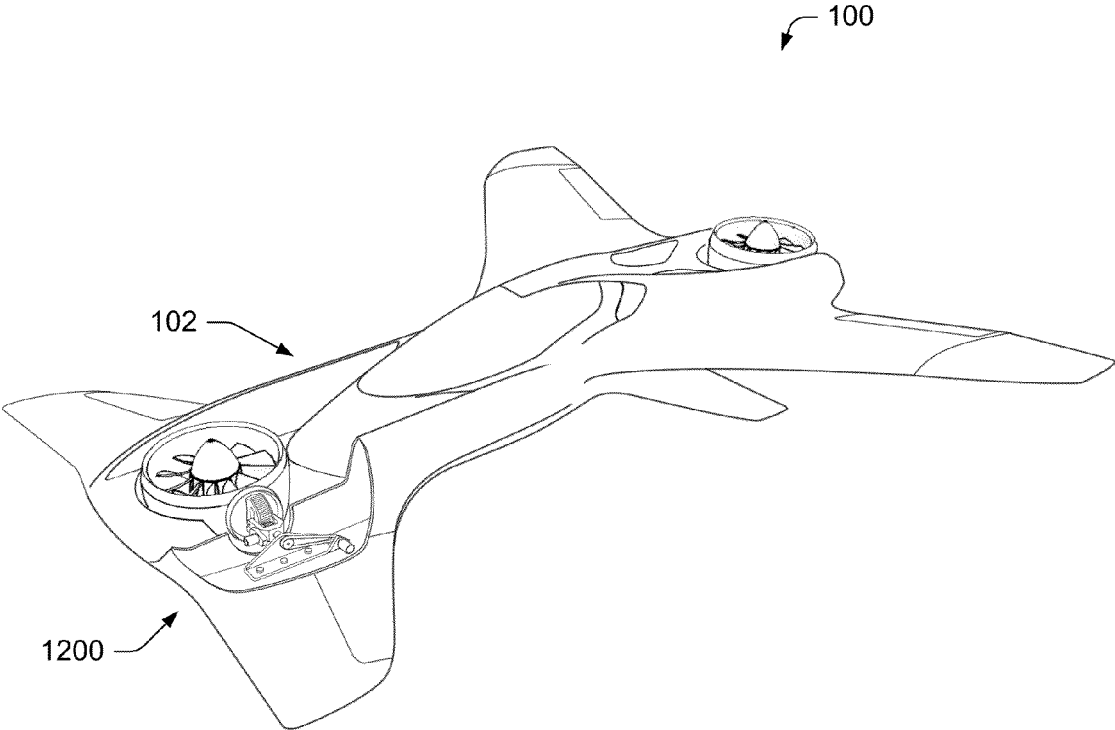

FIG. 12C

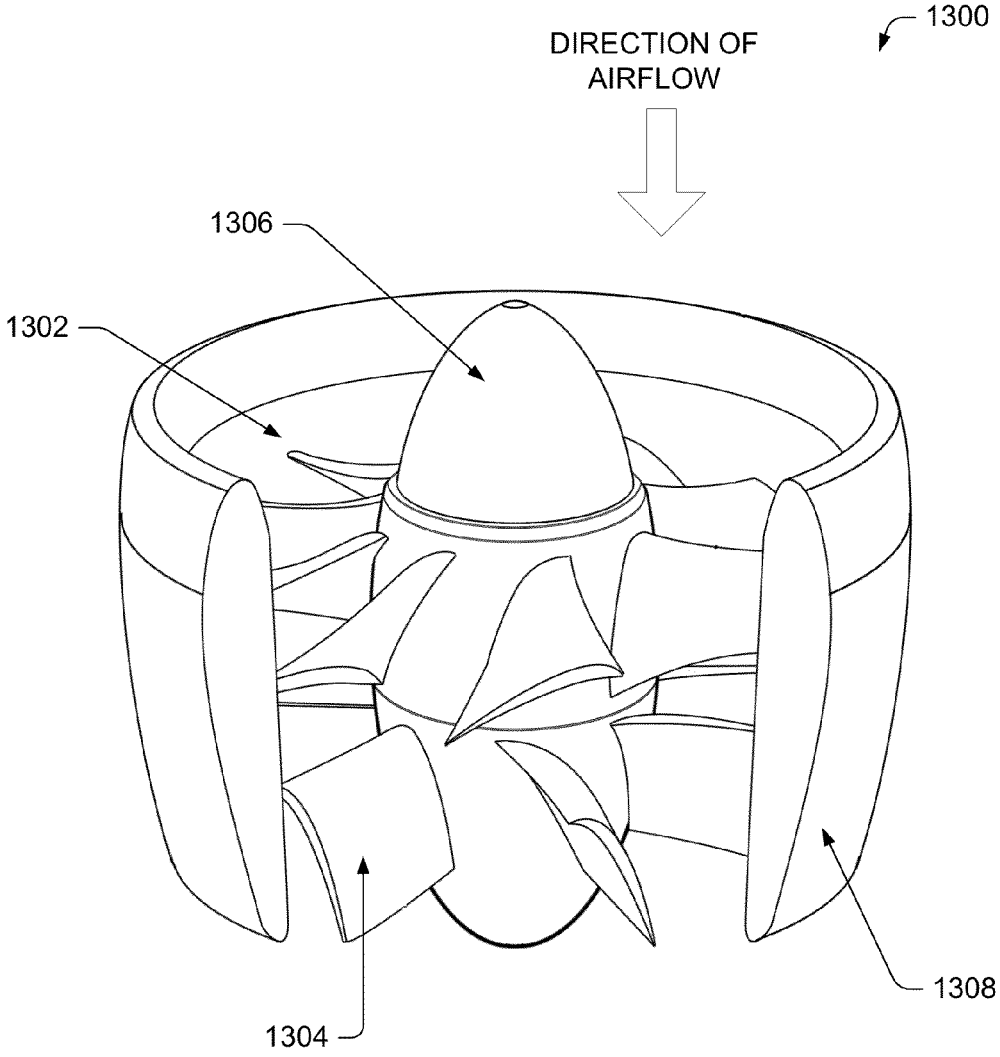

FIG. 13A

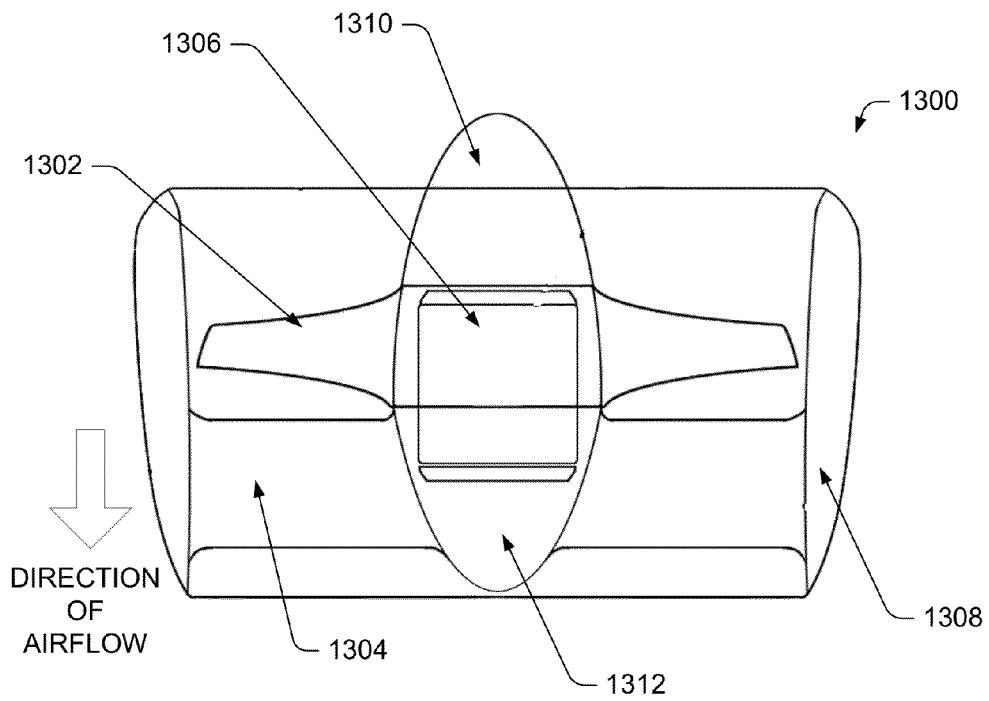

FIG. 13B

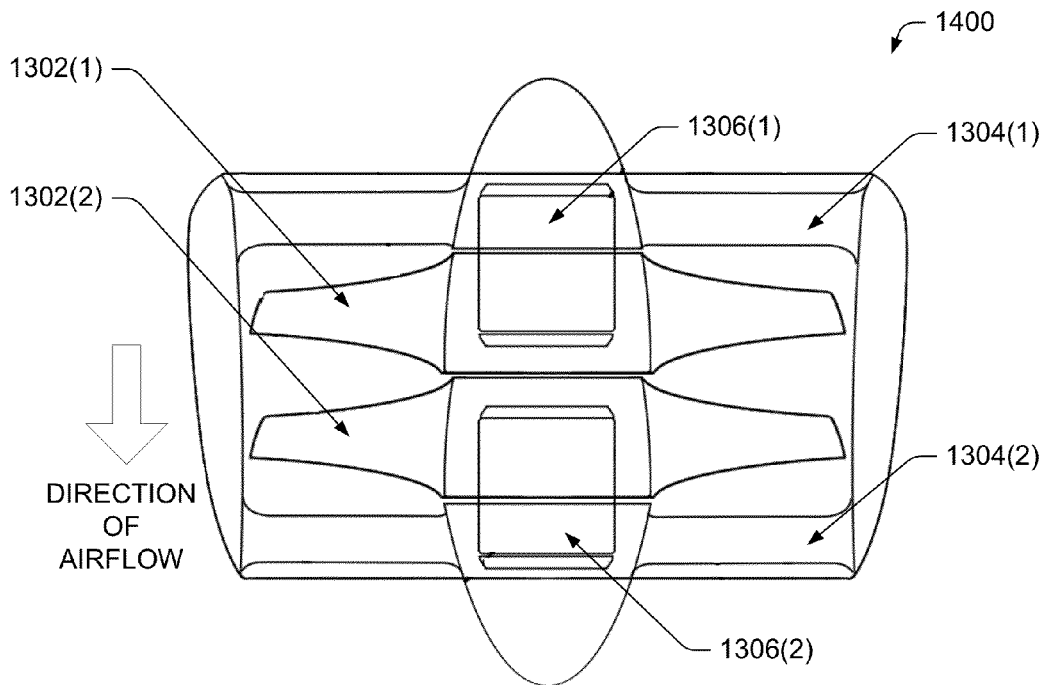

FIG. 14

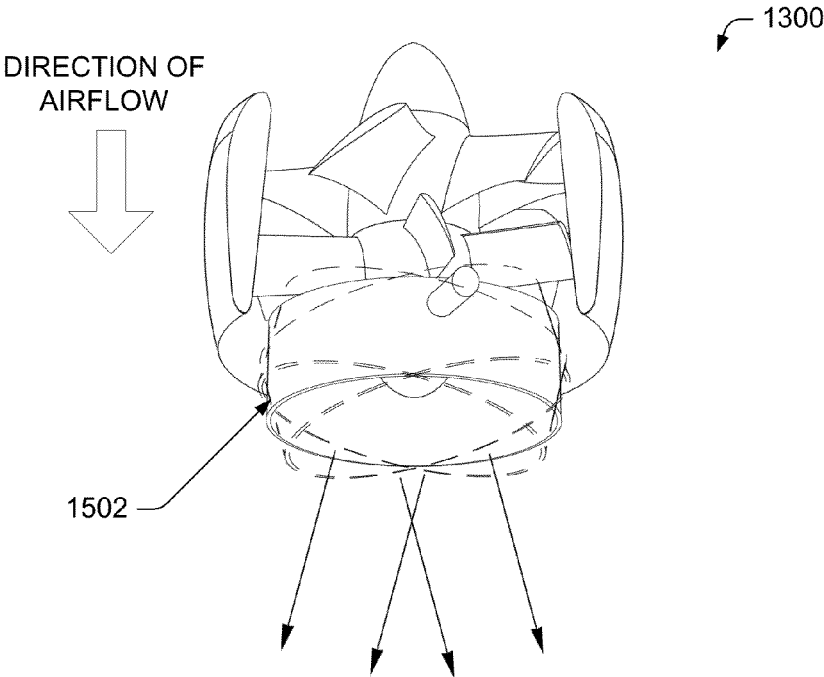

FIG. 15A

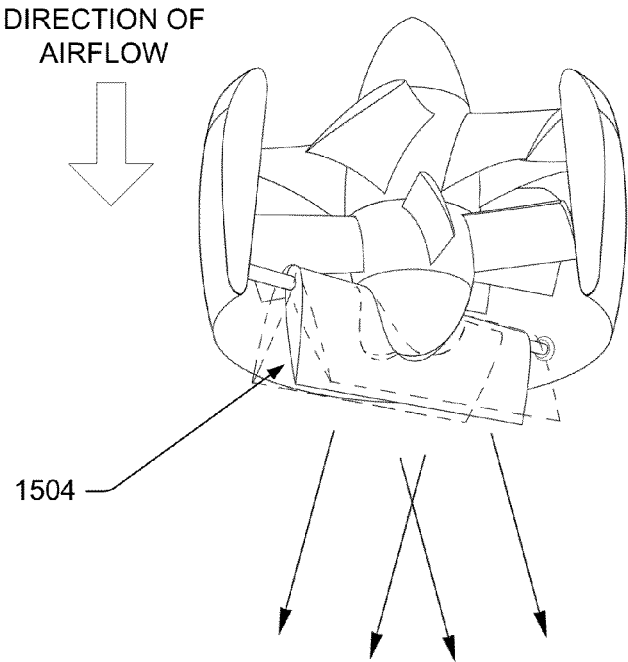

FIG. 15B

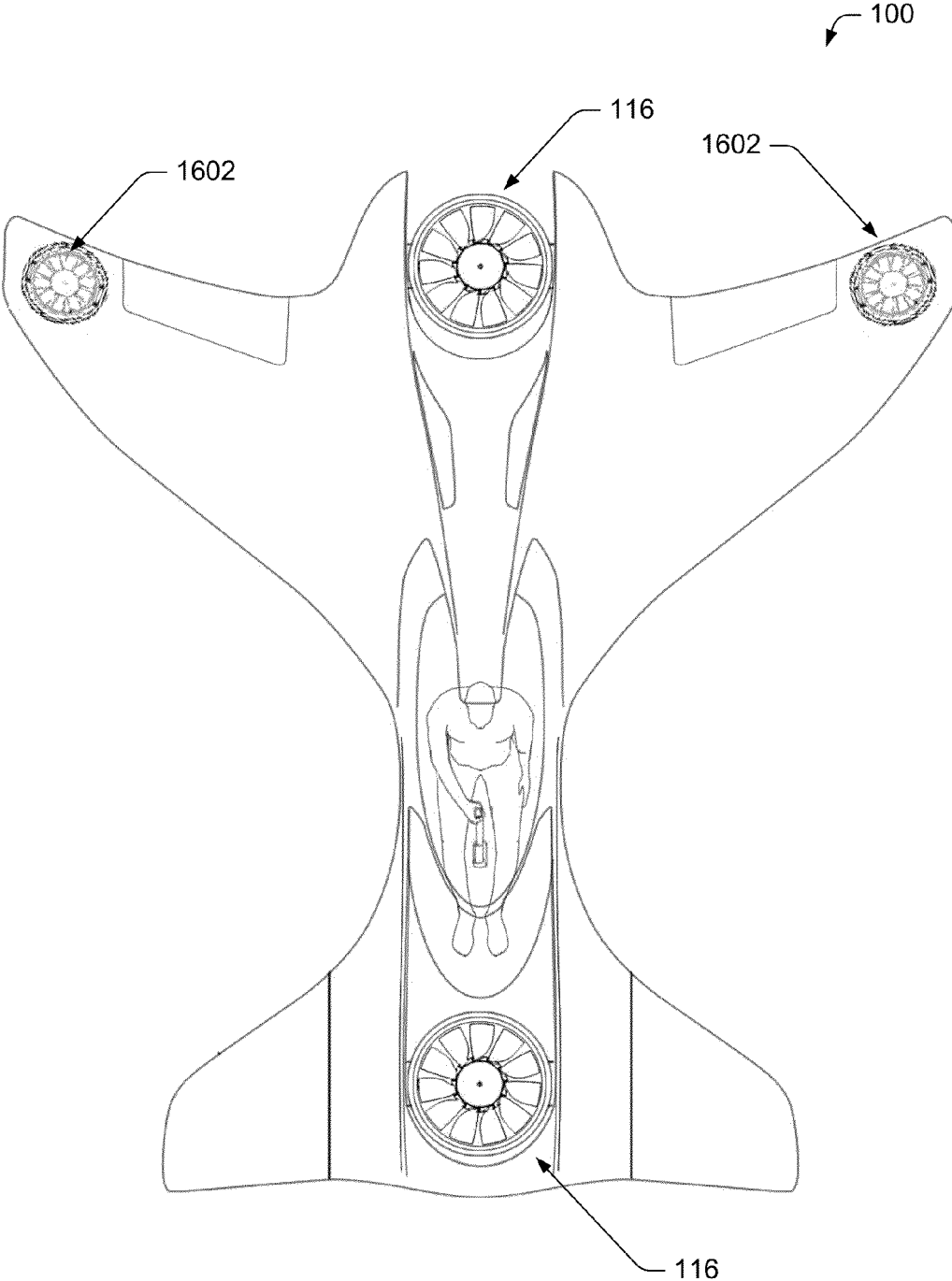

FIG. 16

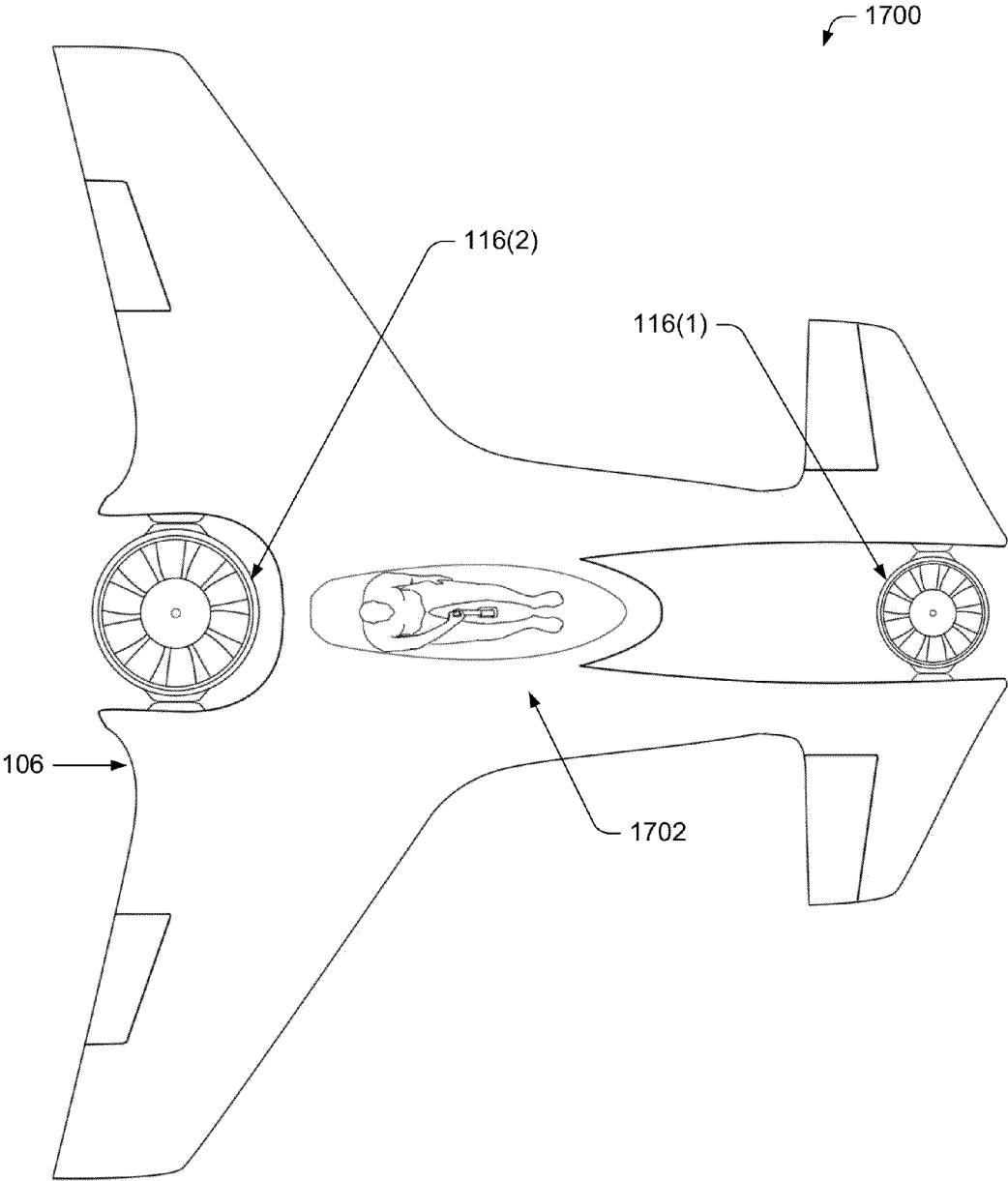

FIG. 17

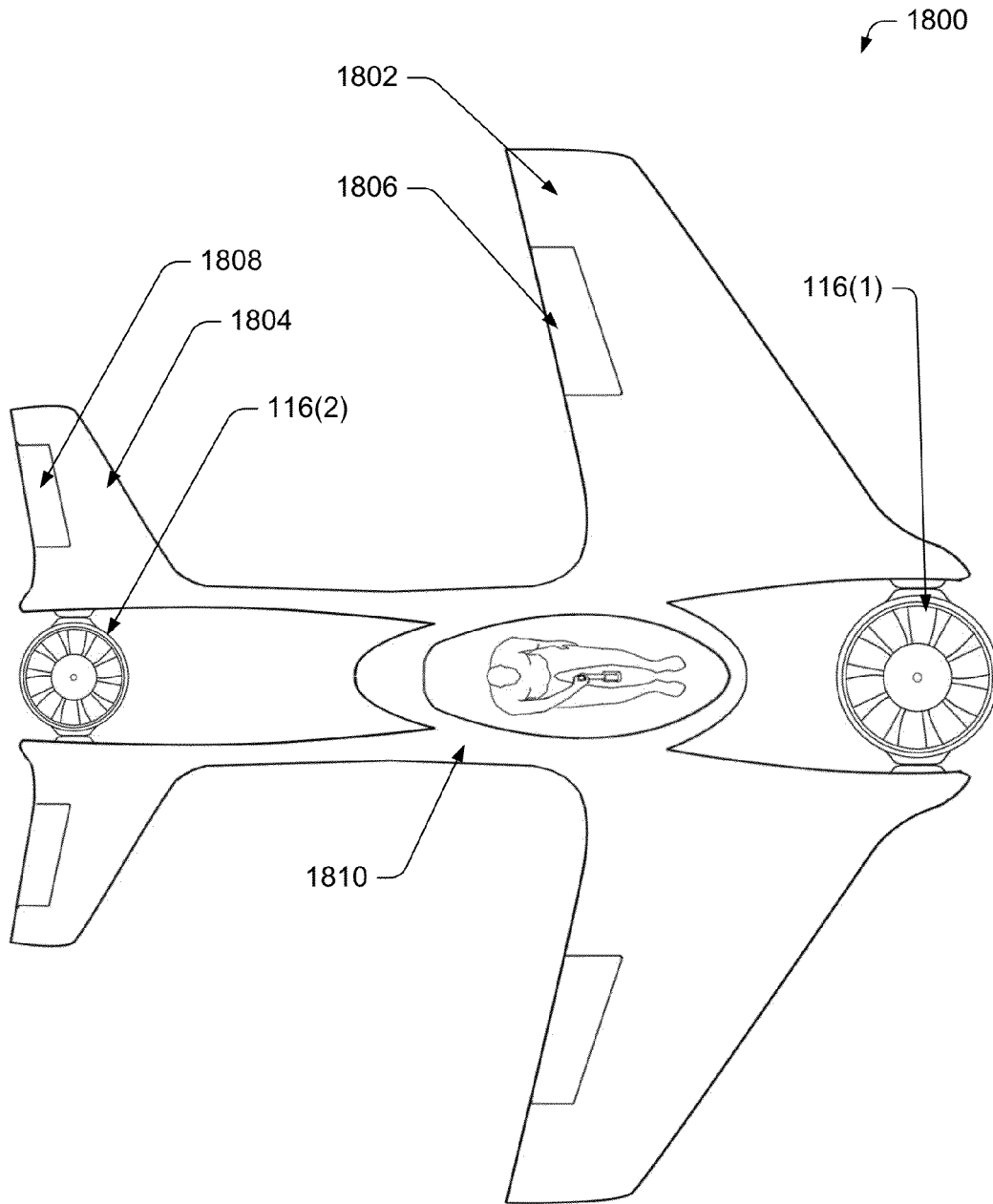

FIG. 18

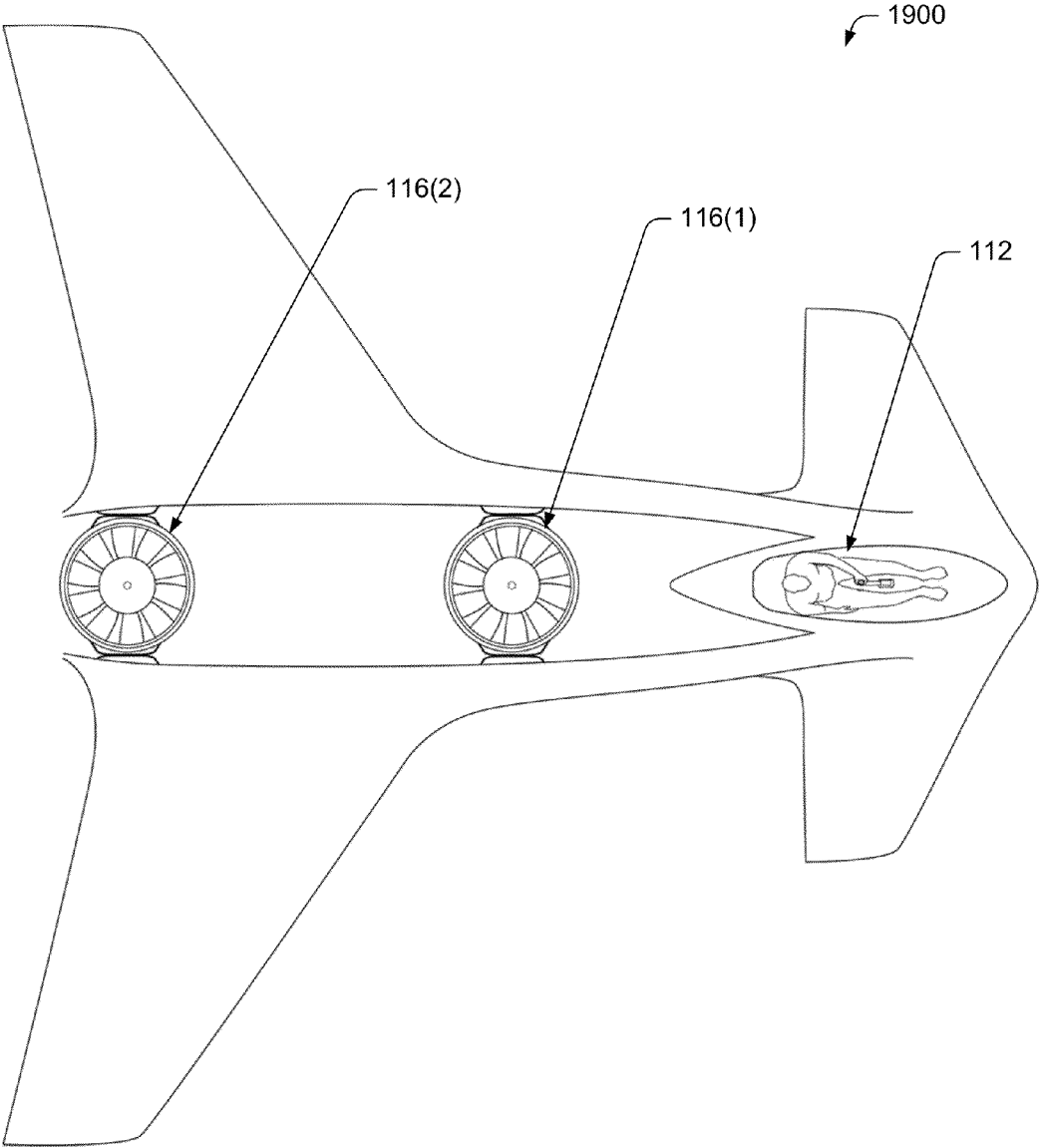

FIG. 19

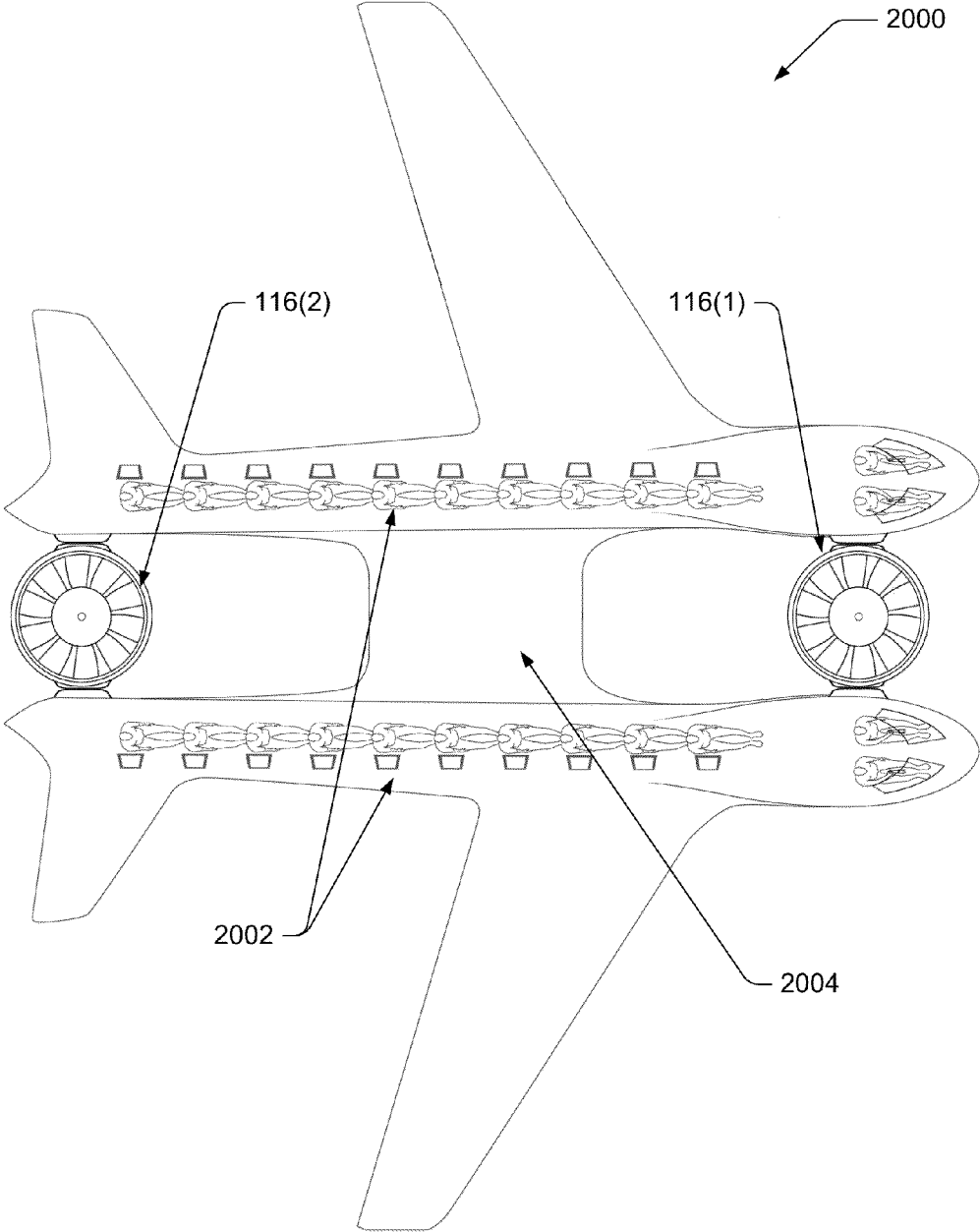

FIG. 20

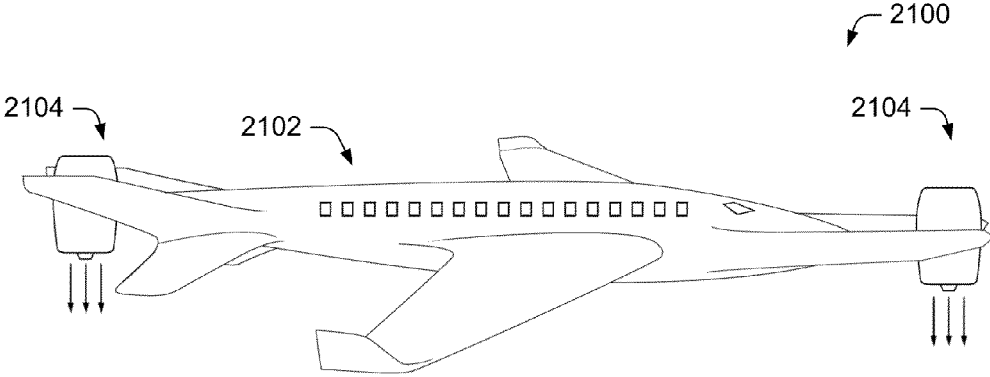

FIG. 21A

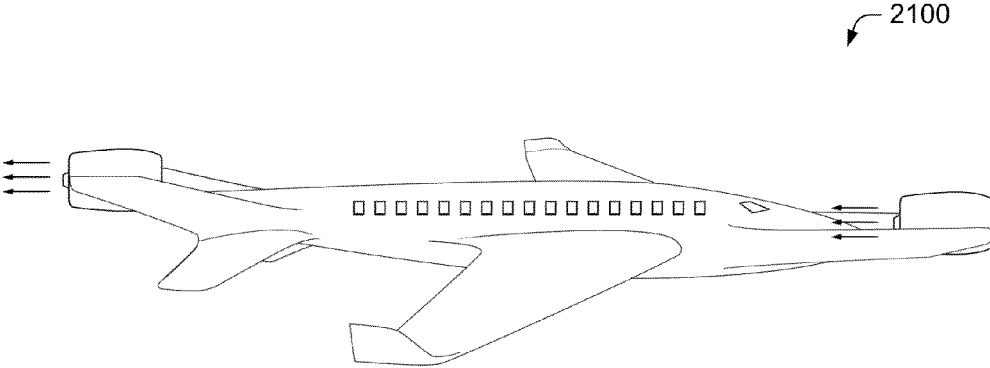

FIG. 21B

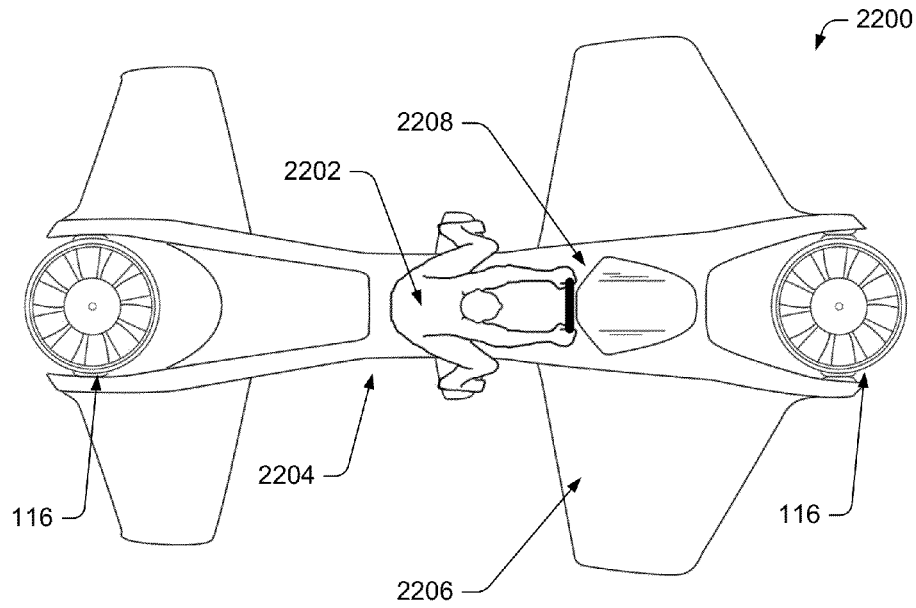

FIG. 22A

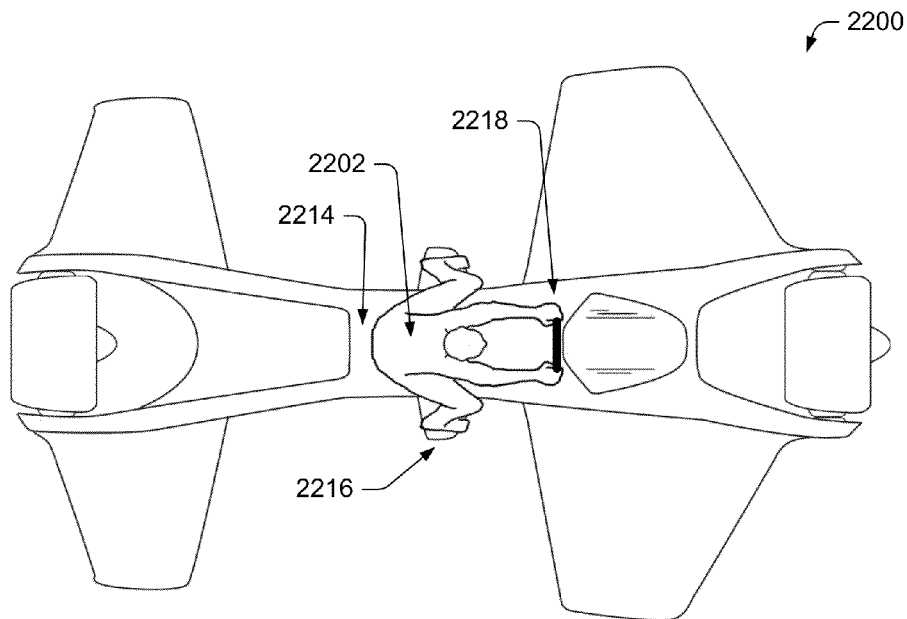

FIG. 22B

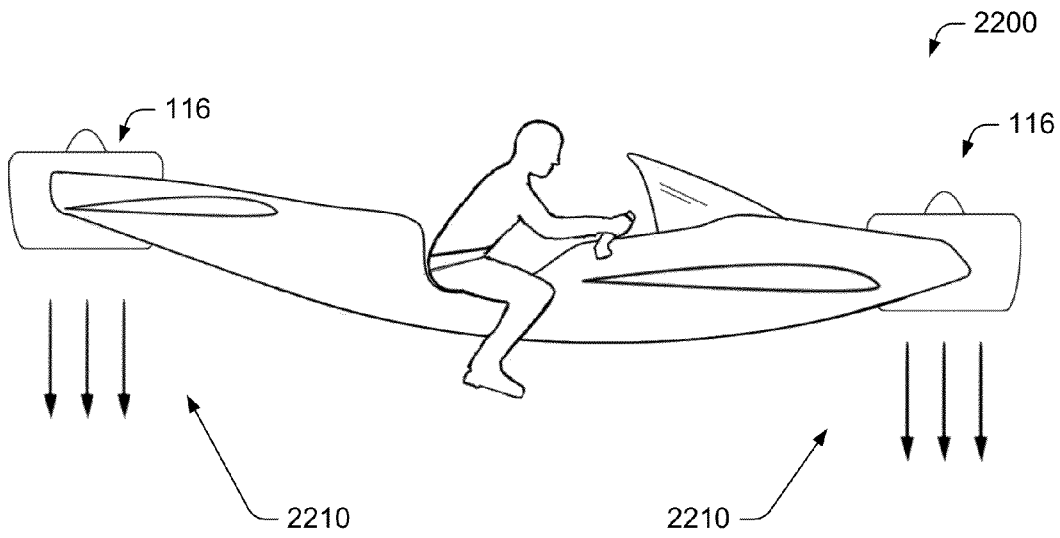

FIG. 22C

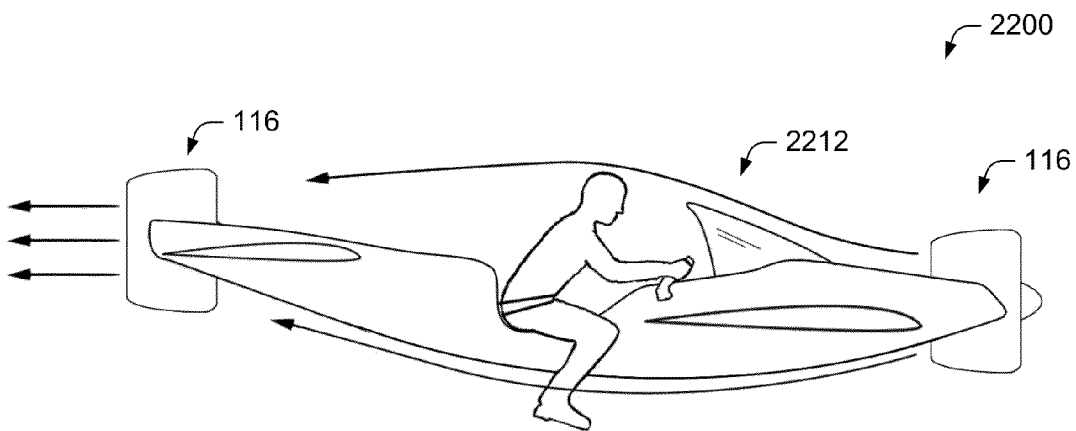

FIG. 22D

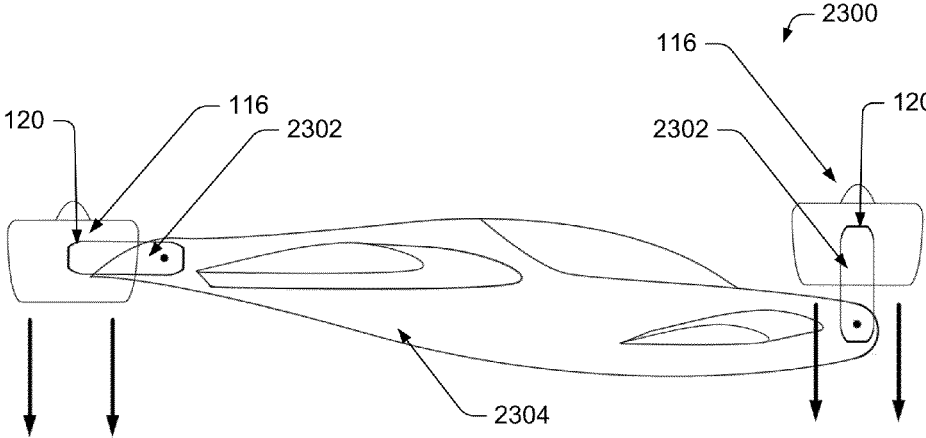

FIG. 23A

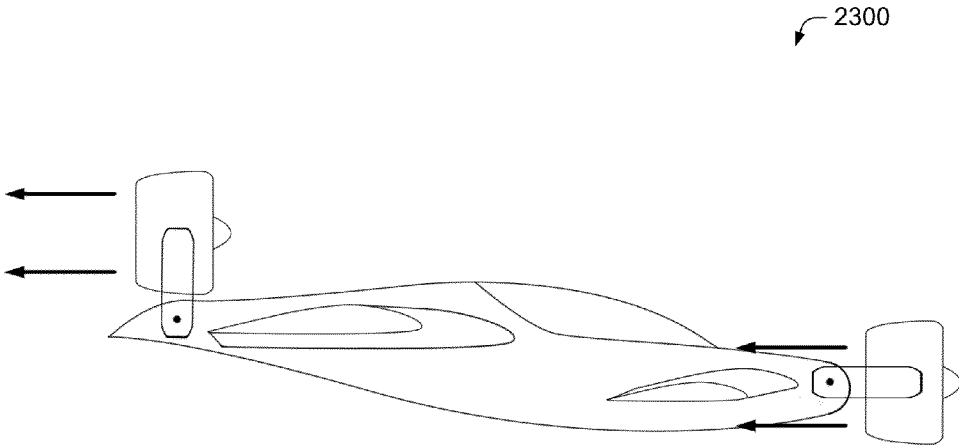

FIG. 23B

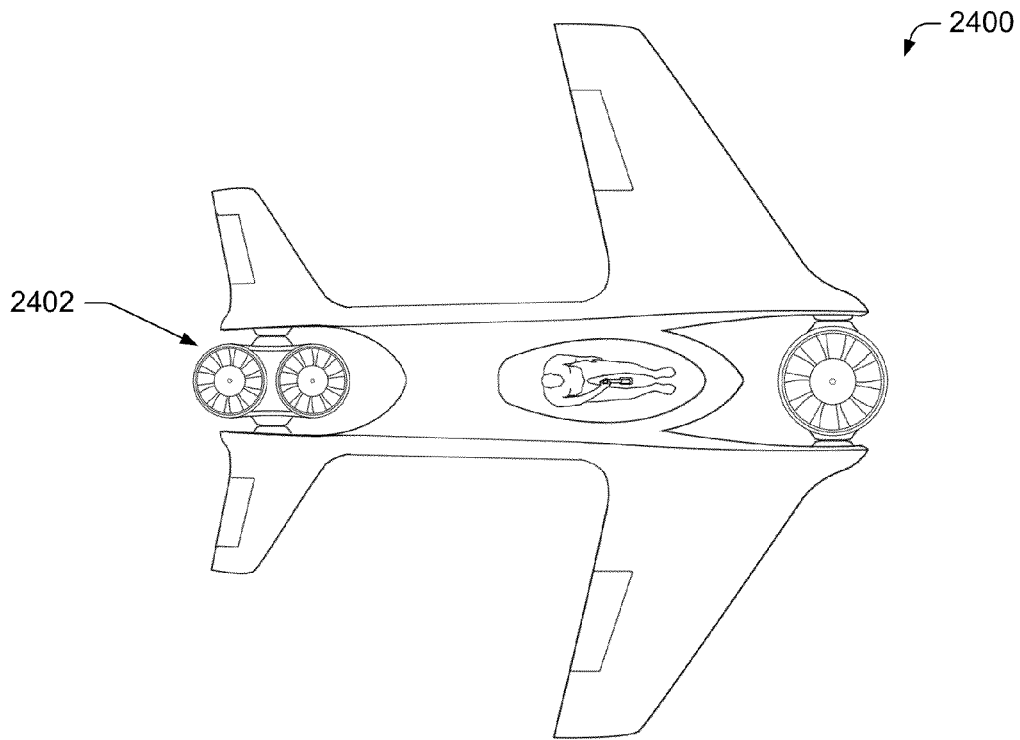

FIG. 24A

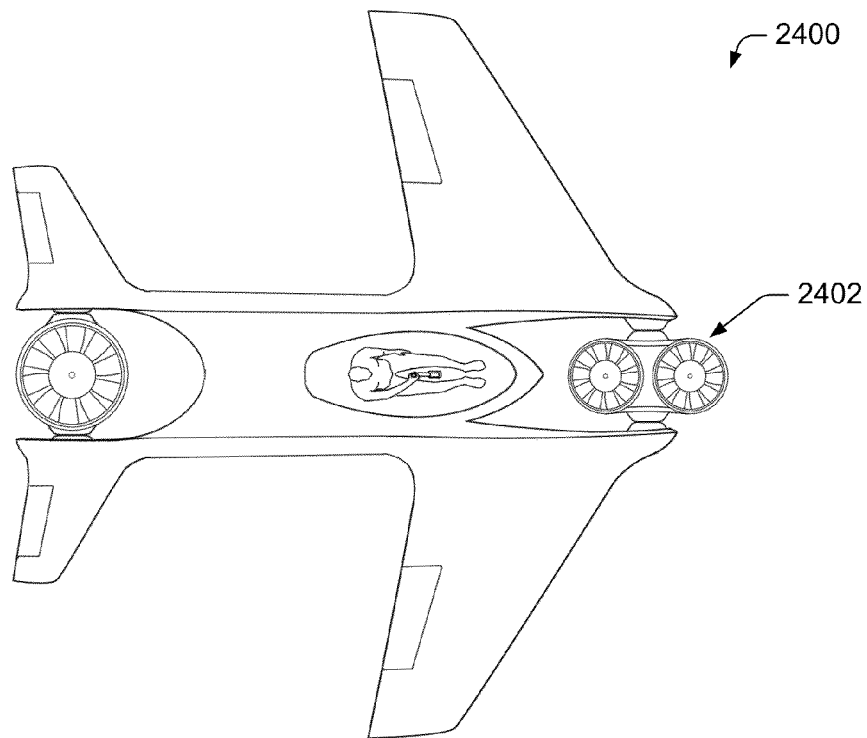

FIG. 24B

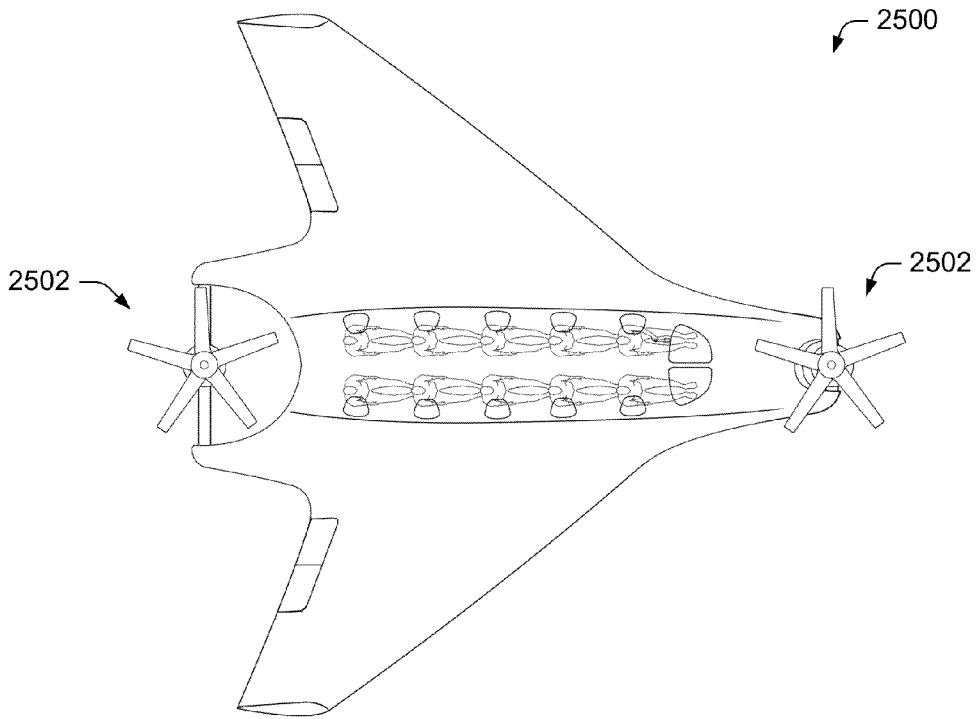

FIG. 25A

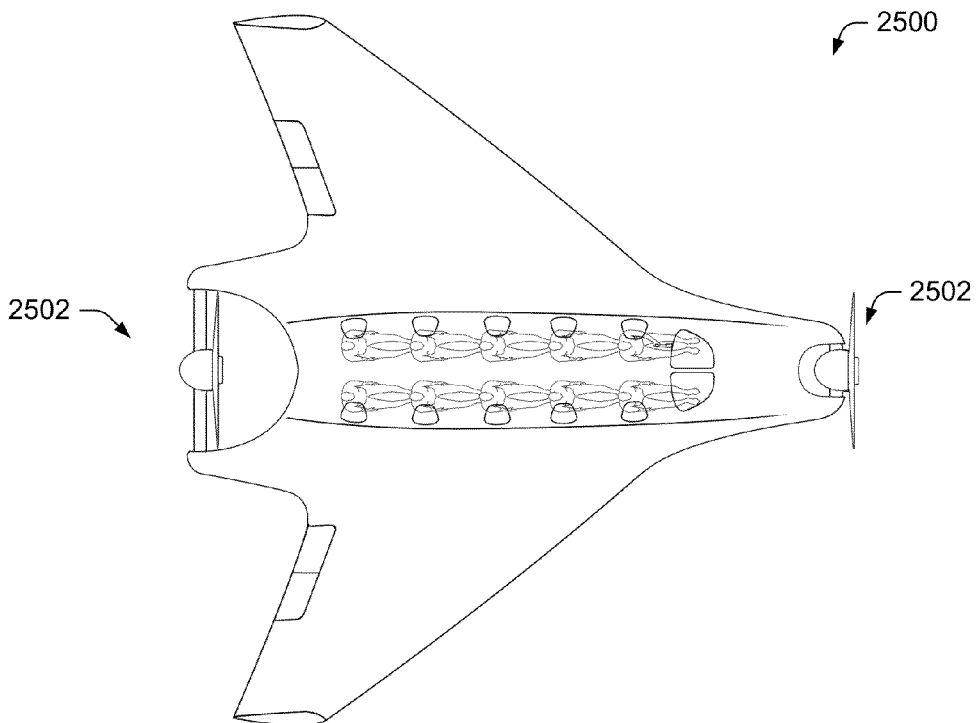

FIG. 25B

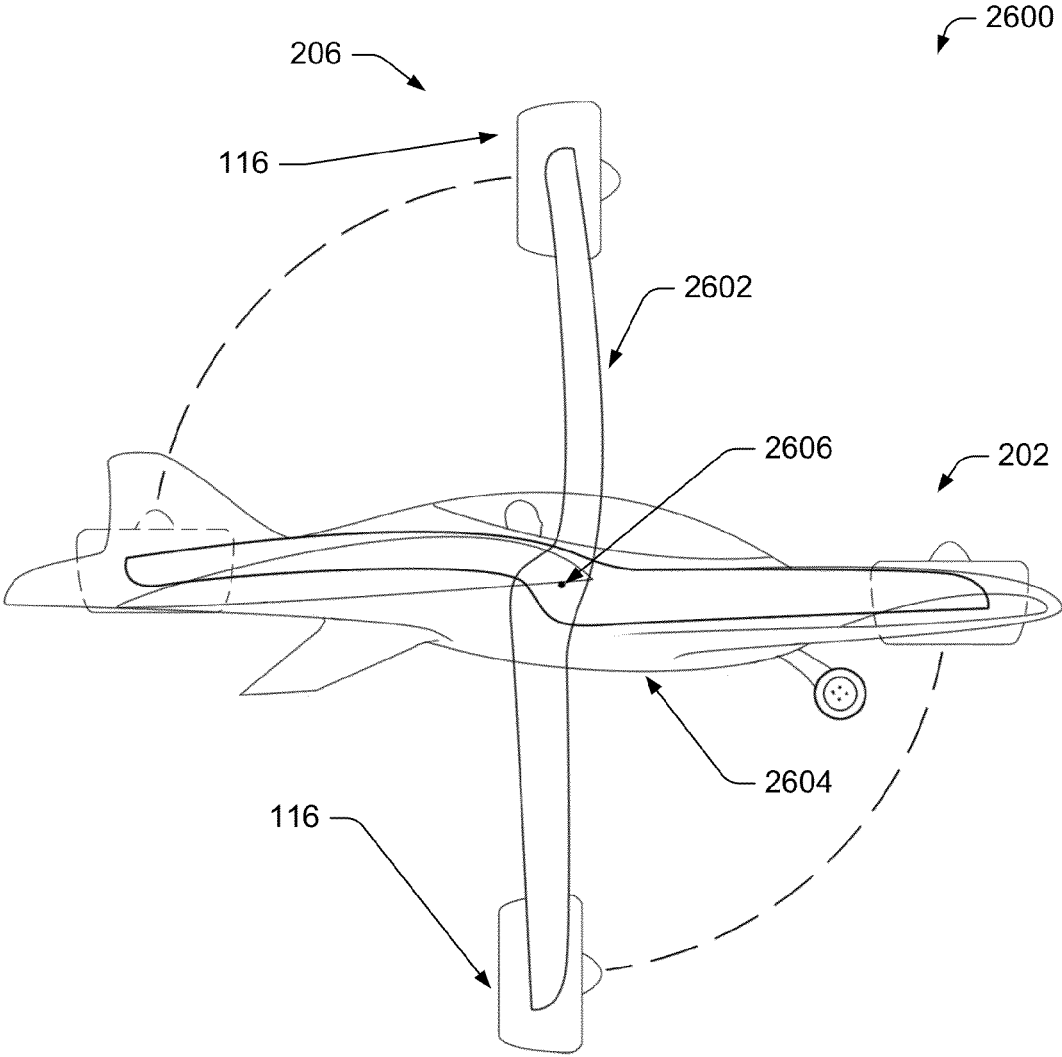

FIG. 26

1

VERTICAL TAKEOFF AND LANDING AIRCRAFT

BACKGROUND

The field of aviation encompasses many different versions of personal aircraft. The vast majority of readily accessible, affordable personal aircraft are fixed wing designs that require the use of a hangar or ramp space for storage, and an air strip for take-off and landing. These requirements increase the overall cost of operating the aircraft, and can render it inaccessible to the average citizen. In addition, most personal aircraft rely on traditional controls and require training and expertise to operate them. The degree of difficulty and knowledge required to operate these aircraft is often multiple times that of driving a traditional automobile, for example.

In contrast, vertical takeoff and landing (VTOL) aircraft can be operated without use of an air strip. Since their inception at the early part of the twentieth century, VTOL aircraft have been powered by internal combustion, turbo-fans or turbo-shaft engines. These types of engines, though reliable, suffer from the threat of engine loss due to foreign object debris (FOD), largely rely on petroleum based products as their fuel, and are highly complex and extremely expensive. The dangerous and cost prohibitive nature of the turbo-fan and turbo-shaft engines used in today's modern VTOL aircraft has deterred their use in the personal aircraft market.

A large number of VTOL aircraft in use today are in the form of tilt-rotor aircraft, and are employed by various militaries throughout the world. Many of these aircraft provide balanced thrust from rotors located on the main wings, thus making them difficult if not impossible to maneuver after a rotor becomes nonoperational. In addition, the overall complexity of today's tilt-rotor aircraft has limited their use to well trained, professional pilots. However, the many advantages of the tilt-rotor platform, including vertical lifting capabilities combined with the speed and efficiency of a conventional fixed wing aircraft, if available to the general public, could revolutionize the transportation industry.

BRIEF DESCRIPTION OF THE DRAWINGS

The detailed description is described with reference to the accompanying figures. In the figures, the left-most digit(s) of a reference number identifies the figure in which the reference number first appears. The same reference numbers in different figures indicate similar or identical items.

FIGS. 1A and 1B are perspective views of an illustrative vertical takeoff and landing (VTOL) aircraft.

FIG. 2 is a schematic diagram showing a transition of flight of an illustrative VTOL aircraft from takeoff to a transitional mode to a forward flight mode.

FIG. 3A is a side elevation view of an illustrative VTOL aircraft with extended landing gear.

FIG. 3B is a side elevation view of an illustrative VTOL aircraft in vertical (hover) flight mode.

FIG. 3C is a side elevation view of an illustrative VTOL aircraft shown in FIG. 2 and shows airflow through rotor units during vertical flight.

FIG. 3D is a side elevation view of an illustrative VTOL aircraft in forward flight mode and shows airflow through rotor units during forward flight.

FIG. 4 is a top view of the illustrative VTOL aircraft shown in FIG. 3B.

FIG. 5 is a top view of the illustrative VTOL aircraft shown in FIG. 1A.

2

FIGS. 6A and 6B are top views of the illustrative VTOL aircraft shown in FIG. 3B and show various components that may be selectively included in the VTOL aircraft.

FIG. 7 is a perspective view of a VTOL unmanned aerial vehicle (UAV).

FIG. 8 is a top view of the illustrative VTOL UAV shown in FIG. 7 and shows various components and compartments including locations of batteries and storage compartments.

FIG. 9A is a front elevation view of the illustrative VTOL aircraft shown in FIG. 3B and shows the fore rotor unit and aft rotor unit configured to provide thrust in a direction of a vertical axis that bisects the aircraft in symmetrical halves.

FIG. 9B is a front elevation view of the illustrative VTOL aircraft shown in FIG. 3B and shows the fore rotor unit and aft rotor unit configured to provide thrust in a direction having an angle α from a vertical axis that bisects the aircraft in symmetrical halves.

FIG. 9C is a schematic diagram showing a transition of flight of an illustrative VTOL aircraft using the rotor units as an air-brake.

FIG. 10 is a partial top view of the illustrative VTOL aircraft shown in FIG. 1A and shows the fore rotor unit configured to provide directed thrust in a direction between an angle β from a longitudinal axis of the fuselage.

FIGS. 11A-11C are isometric views of an illustrative rotating assembly that connects a rotor to the fuselage of the illustrative VTOL aircraft.

FIGS. 12A-12C are views of a rotor and illustrative apparatus to cause lateral movement of the rotor in accordance the FIGS. 9B and 10.

FIG. 13A is a partial cutout perspective view of an illustrative rotor unit.

FIGS. 13B and 14 are side elevation views of illustrative rotor units.

FIGS. 15A and 15B are partial cutout isometric views of the illustrative rotor unit shown in FIG. 13 and show lateral thrust directing apparatuses.

FIG. 16 is a top view of an illustrative VTOL aircraft that includes wingtip rotors.

FIG. 17 is a top view of an illustrative VTOL aircraft having a shortened fuselage and rotors selected to balance a payload of the VTOL aircraft.

FIG. 18 is a top view of an illustrative VTOL aircraft having a traditional wing configuration.

FIG. 19 is a top view of an illustrative VTOL aircraft where the fore rotor unit is located between the aft rotor unit and a cockpit.

FIG. 20 is a top view of an illustrative multi-occupant VTOL aircraft.

FIGS. 21A and 21B are side elevation views of another illustrative multi-occupant VTOL aircraft.

FIGS. 22A and 22B are top views of an illustrative VTOL aircraft where the operator straddles the fuselage.

FIGS. 22C and 22D are side elevation views of an illustrative VTOL aircraft.

FIGS. 23A and 23B are side elevation views of an illustrative VTOL aircraft and show pivoting arms that connect the rotor units to the fuselage.

FIGS. 24A and 24B are top views of an illustrative VTOL aircraft and show a cluster of rotor units.

FIGS. 25A and 25B are top views of an illustrative VTOL aircraft using non-ducted rotors.

FIG. 26 is a side elevation view of another aircraft using rotor units coupled to a rotatable arm.

DETAILED DESCRIPTION

This disclosure is directed, in part, to a vertical takeoff and landing (VTOL) aircraft that includes fixed wing flight capa-

bilities. The VTOL aircraft may include thrust producing rotors located on opposite ends of a fuselage and along a longitudinal axis of the fuselage. The rotors may be electric ducted fans. However, other power sources may be used such as gas powered rotor units. Each rotor unit may be coupled to the fuselage via a rotating or pivoting chassis, which allows each rotor unit to provide directed thrust by movement of the rotor unit about at least one axis. By moving the rotor units, the aircraft can transition from a hover mode to a transition mode and then to a forward flight mode and back. The aircraft may take off without use of an airstrip by liftoff into the hover mode. While in the hover mode, the rotors may generate thrust that is directed primarily in a downward direction relative to the fuselage. Once the aircraft has gained altitude after sustained flight in the hover mode, the rotor units may transition, during the transition mode, to a forward-flight mode where the rotors generate centerline thrust directed primarily toward the aft of the fuselage. The rotor units may later transition back to the hover mode to enable the aircraft to land without use of an airstrip.

The aircraft may include fixed wings to enable prolonged flight with minimal thrust from the rotors. In some embodiments, the aircraft may include a canard wing at the fore end of the fuselage and a delta-shaped main wing at the aft end of the fuselage. However, other wing configurations may be used as discussed below. The wings may include ailerons, flaps, flaperons, and any other control surfaces necessary to control the aircraft in forward flight. In some embodiments, the rotors may provide directed lateral thrust to assist in yaw and roll control of the aircraft.

In accordance with various embodiments, the VTOL aircraft may employ a flight control computer that controls and sustains flight in each of the flight modes (hover mode, transition mode, and forward-flight mode). Operation of the aircraft may be performed by providing simple directional commands from operator controls to the flight control computer, which in turn executes the commands while taking other necessary action to sustain flight and/or avoid objects in the surrounding environment. Thus, control of the aircraft from the operator's perspective may be akin to control of an aircraft in a video game, and may be made possible with minimal training or aviation expertise. In some embodiments, the VTOL aircraft may be an unmanned aerial vehicle (UAV) or a remote-controlled aircraft.

The apparatuses, systems, and techniques described herein may be implemented in a number of ways. Example implementations are provided below with reference to the following figures.

FIGS. 1A and 1B are perspective views of an illustrative vertical takeoff and landing (VTOL) aircraft.

FIG. 1A is an isometric view of an illustrative VTOL aircraft 100 while the VTOL aircraft is in the hover mode. The aircraft in FIG. 1 has a fuselage 102 with a fore end 104, an aft end 106, a top side 108, and a bottom side 110. The VTOL aircraft 100 may include a cockpit 112 located within the top side 108 of the fuselage 102. The cockpit 112 includes space for at least one operator to sit for manned flight. In some embodiments, the cockpit 112 may include space for one or more passengers and/or other payload. In some embodiments, the VTOL aircraft 100 may be equipped for unmanned flight. The cockpit 112 may include a canopy 114 that provides a weatherproof and relatively quiet environment. The canopy 114 may be formed of acrylic, plastic, glass, or any other transparent material.

The VTOL aircraft 100 includes at least two rotor units 116, including a fore rotor unit 116(1) and an aft rotor unit 116(2) that produce thrust for propulsion in a push-pull con-

figuration. The rotor units 116 are located along a longitudinal axis 118 of the fuselage 102. The rotor units may be located along a same plane or along different planes (e.g., one rotor unit located closer to the top side 108 of the fuselage 102 than the other rotor unit, etc.). The rotor units 116 may be powered by electric motors or by gas powered engines. In some embodiments, a hybrid system may be used to convert liquid fuel to electrical energy to drive electric motor powered rotors and/or a fuel powered generator may provide electrical power to electric motors.

In accordance with one or more embodiments, the rotors 116 may be counter-rotating, in which the rotor of the fore rotor unit 116(1) spins clockwise, while the rotor of the aft rotor unit 116(2) spins counter-clockwise, or vice versa. The rotor units 116 may consist of a rotor vane, or both a rotor vane and a straightening vane (stator). In some embodiments that include both the rotor vane and the straightening vane, the rotor vane on both the fore rotor unit and aft rotor unit may rotate in the same direction. The straightening vane may be implemented with a stator that is fixed in place and supports the rotor vane. The straightening vane may be comprised of a plurality of aerodynamic blades, configured to counter the vortex imparted on the thrust from the rotor vane.

The push-pull configuration of the rotor units 116 may allow for greater controllability when only one rotor unit provides thrust in the forward-flight mode because the rotor units 116 are both located along the longitudinal axis 118 and in substantial alignment with direction of forward flight. Therefore, there may be minimal imparted yaw or roll on the VTOL aircraft 100 when only one rotor unit provides forward thrust. The VTOL aircraft 100 may operate in a push mode, in which the fore rotor unit 116(1) provides little or no thrust or a pull mode, in which the aft rotor unit 116(2) provides little or no thrust. The VTOL aircraft may also operate in a glide mode, in which the rotor units 116 provide little or no thrust.

In some embodiments, the rotor units 116 are equipped with a plurality of blades surrounded by a duct (ducted rotor units). Ducted rotor units may provide a high thrust-to-diameter ratio compared to an open propeller. Ducted rotor units are also very efficient because the duct reduces losses in thrust due to tip vortices. The reduction of tip vortices increases the efficiency of both rotor units due to reduced drag on the tip of each blade while operating within a duct. Furthermore, the reduction of tip vortices increases the efficiency of the aft rotor unit due to decreased turbulent air flow from the fore rotor unit. This increased efficiency provides an increase in thrust from the rotor unit during the forward flight mode.

In various embodiments, the rotors may not include the duct (non-ducted rotors). When the VTOL aircraft is configured with non-ducted rotors, the fuselage 102 and/or the canopy 114 may be equipped with vanes to guide laminar airflow directly to the aft rotor unit 116(2). In some embodiments, a dissipation mechanism may be used to divert turbulent air away from the aft rotor unit 116(2), thereby increasing laminar air flow to the aft rotor unit 116(2) and increasing the efficiency of the aft rotor unit 116(2).

In some embodiments, the rotor units 116 may include a housing, a stator coupled to an interior of the housing, a plurality of blades, and an electric motor coupled to the stator and coupled to the plurality of blades. The housing (when ducted) guides airflow through the rotor unit, and increases the efficiency of each rotor unit. The rotor units 116 may be approximately the same size. However different sized rotor units may be used to balance a payload of the VTOL aircraft 100 for flight in the hover mode.

Each rotor unit (107) may be mounted in a rotating chassis 120. The rotating chassis 120 for the fore rotor unit 116(1)

may be coupled to the fore end **104** of the fuselage **102**, possibly between or within a fore wing **122** (such as a canard wing). The rotating chassis **120** for the aft rotor unit **116(2)** may be attached to the aft end **106** of the fuselage **102**, possibly between or within an aft wing **124**. In some embodiments, the rotating chassis may be a gimbaled chassis or a pivoting chassis.

The rotating chassis **120** may allow for at least partial freedom of movement of the rotor unit about the longitudinal axis **118** and a lateral axis **126** of each of the rotor units **116**. The rotor units **116** may move independently of one another, based on a signal from a control management system. The control management system processes signals from an operator (on board operator, remote operator, or both) and a plurality of stability augmentation sensors, and sends an output signal to each of the rotor units **116**, directing each of the rotor units to move about the longitudinal axis and the lateral axis as necessary.

FIG. 1B shows the illustrative VTOL aircraft **100** in a forward-flight mode. The rotor units **116** may move about the lateral axis **126** to transition from the hover mode (shown in FIG. 1A), in which the rotor units **116** direct thrust substantially perpendicular to the longitudinal axis **118** and the lateral axis **126**, through a transition mode, to the forward flight mode shown in FIG. 1B, in which the rotor units **116** direct thrust substantially in line with the longitudinal axis **118**. The movement about a vertical axis that is perpendicular to the longitudinal axis **118** and the lateral axis **126** may provide directed thrust for yaw control during forward flight. In some embodiments, the rotor units **116** may also include a vane at the exhaust, which may operate to direct thrust from the rotor units **116**.

The VTOL aircraft **100** may comprise a monocoque structure, made of carbon fiber, titanium, aluminum, or any other material appropriate for aircraft construction. In another embodiment, the structure may comprise a semi-monocoque design, with a shell and longerons made of carbon fiber, titanium, aluminum, or any other material appropriate for aircraft construction. The aircraft skin is a low friction surface that may include built-in solar cells.

In some embodiments, the fore wing **122** may be a canard wing and the aft wing **124** (main wing in this configuration) may be a delta wing. However, other wing configurations may be used and are described below with reference to some illustrative aircraft. The fore wing **122**, coupled to the fore end **104** of the fuselage **102**, may act as a lifting surface and provide pitch stability in the forward-flight mode. The canard wing may have control surfaces **130** such as ailerons, to allow for maneuverability about the longitudinal axis **118** of the VTOL aircraft **100**. The ailerons, elevators, rudder are actuated in normal fashion during forward flight

The aft wing **124** is attached to the aft end **106** of the fuselage **102** and may be a lift-generating airfoil. The aft wing **124** may be a conventional shaped airfoil, a delta wing, or an ovalar shaped wing. The aft wing **124** may be equipped with control surfaces **132**, comprised of a set of any of the following alone, or in combination: ailerons, flaps, flaperons, and any other control surface which may enable the operator to control the roll, and/or speed of the VTOL aircraft **100** while in the forward-flight mode. The control surfaces **132** on the aft wing **124** may also be configured to move simultaneously in the same direction, thereby providing pitch control of the VTOL aircraft **100** while in forward flight.

The VTOL aircraft **100** may include ventral fins **134** that extend outward from the bottom side **110** of the fuselage **102** near the aft end **106**. The ventral fins **134** may provide directional stability (e.g., yaw and pitch stability). In some

embodiments, the ventral fins **134** may house and/or support landing gear and/or control surfaces, and also serve as energy absorbing devices during hard landings. The landing gear may be implemented as in a tricycle-style configuration that includes two aft struts and one fore strut which may or may not be retractable after take-off in order to reduce drag.

A fixed or movable portion of the fuselage or body surface **136** may enhance inlet airflow entering the rotor units during conversion from hover to forward flight. This may improve the airflow entering the ducts giving better efficiency with less turbulence and/or drag from inlet lip flow separation.

FIG. 2 is a schematic diagram showing a transition of flight of an illustrative VTOL aircraft from a hover mode **202** to a transitional mode **204** to a forward-flight mode **206**.

The hover mode **202** may be initiated prior to takeoff. In the hover mode **202**, the rotor units **116** may be substantially parallel to the ground. Landing gear **208** may be deployed. The control management system may make rapid micro and/or macro adjustments to the thrust level and direction of each of the rotor units **116** to support flight in the hover mode **202**. The operator may direct the aircraft in the hover mode **202**, which may include providing directional data to the control management system. After take-off into the hover mode **202**, the operator may direct the aircraft to remain in the hover mode, or start a transition to forward flight, via the transition mode **204**.

The transition mode **204** may be a temporary mode used to transition between the hover mode **202** and the forward-flight mode **206**. However, the VTOL aircraft **100** may sustain prolonged flight in the transition mode **204**. The transition mode may be controlled largely by the control management system. In the transition mode **204**, the rotor units **116** may rotate substantially simultaneously from a position that directs thrust downward toward the ground (used in the hover mode **202**) to a position that directs thrust rearward to cause forward flight. In the transition mode **204**, the fore wing **122** and the aft wing **124** may begin to generate some lift, and the control surfaces **130**, **132** may become effective to control the pitch and roll of the VTOL aircraft **100**. The VTOL aircraft **100** initiates the forward-flight mode **206** once airspeed of the VTOL aircraft **100** has reached a threshold airspeed and the wings provide lift. In some embodiments, the thrust from one or more of the rotor units **116** may be significantly reduced once the VTOL aircraft **100** begins operation in the forward-flight mode because the lift provided by the wings may replace the lift generated by the rotor units **116** during the hover mode **202** and during the transition mode **204**.

In the forward flight mode **206**, the rotor units **116** may operate in a push-pull capacity to generate thrust and propel the aircraft forward. In the forward flight mode **206**, the rotor units may provide directed thrust under control of the operator and/or the control management system. The directed thrust may increase the stability of the aircraft in forward flight mode.

FIGS. 3A-3D show the illustrative VTOL aircraft **100** in various operational modes. FIG. 3A is a side elevation view of an illustrative VTOL aircraft with extended landing gear. The VTOL aircraft **100** may include the landing gear **208** that is fixed or retractable. The aft landing gear may be coupled to the ventral fins **134**. The landing gear may be implemented as in a tricycle-style configuration that includes two aft struts and one fore strut which may or may not be retractable after take-off in order to reduce drag. However, other configurations of the landing gear **208** may be used depending on the type of wings used in the VTOL aircraft **100**. For example, when the VTOL aircraft **100** is configured with the fore wing

122 as a main wing, then the landing gear may include two fore struts and one aft strut (tail dragging configuration).

The fore wheel **302** may extend and retract from the fuselage **102**. The fore wheel **302** may include a fore strut **304** that provides some shock absorption for the fore wheel **302**. In some embodiments, the ventral fins **134** may be coupled to an aft strut or may act as the aft strut.

FIG. 3A also shows the rotation of the rotor units **116**, thereby enabling the transition from hover mode **202** to forward flight mode **206**, and vice versa, as described above. FIG. 3A also shows a rotor unit configuration whereby conventional launches and landings may be accomplished, as the rotating ducts are clear of the ground plane in forward flight mode.

FIG. 3B is a side elevation view of the illustrative VTOL aircraft **100** in the hover mode **202**. FIG. 3B shows the fore rotor unit **116(1)** being located on a lower plane than the aft rotor unit **116(2)**. However, the fore rotor unit **116(1)** may be located on a higher plane or a same plane as the aft rotor unit **116(2)**. Turbulent airflow from the fore rotor unit **116(1)** may be at least partially diverted away from the aft rotor unit based on the placement of the rotor units with respect to the fuselage while the rotor units **116** are still situated along the longitudinal axis **118**. The diversion of airflow allows more undisturbed air to reach the aft rotor unit **116(2)**, possibly increasing an efficiency of the aft rotor unit **116(2)**.

As previously discussed, the VTOL aircraft **100** may include a cockpit **112** mounted on the top side **108** of the fuselage **102**. The cockpit **112** may include space for an operator to sit for manned flight. The cockpit **112** may include hardware, controls, the control management system (or portions thereof), and/or other control, navigational, or flight equipment. In some embodiments, the VTOL aircraft **100** may be equipped for unmanned flight, and therefore may or may not include the cockpit **112**.

FIG. 3C is a side elevation view of an illustrative VTOL aircraft **100** shown in FIG. 3B and shows airflow **306** through the rotor units **116** during vertical flight in the hover mode **202**. The airflow **306** may create a low pressure volume **308** above the rotor units **116** and a high pressure volume **310** below the rotor units **116**. The low pressure volume **308** sustains flight by drawing the respective portion of the aircraft toward the low pressure volume **308**. The low pressure volume **308** and the high pressure volume **310** create a pressure differential across the airflow **306**. The pressure differential creates the lift needed to keep the aircraft airborne, while the rotor units **116** move air to create thrust. The higher location of the low pressure volume **308** provides stability to flight of the VTOL aircraft **100** that is akin to attachment of ends of a hammock that create stability to a body supported by the hammock. A low center of mass **312** relative to the pressure centers **314** of the rotor units creates inherent stability via the pendulum effect.

The airflow **306** through the rotor units **116** lifts the VTOL aircraft **100** into a hover. The airflow **306** is determined based in part on a speed of rotation of the rotors **116**, a pitch of the blades in the rotor units, and other factors. The rotors **116** may rotate at a same speed during hover, or they may rotate at a different speed during hover. The speed of each of the rotors **116** is determined by the control management system based on operator input and sensor input of stability augmentation sensors. The fore rotor unit **116(1)** and the aft rotor unit **116(2)** may be the same size or may be different sizes. The rotor units **116** produce enough lift to maintain a hover in and out of ground effect.

FIG. 3D is a side elevation view of the illustrative VTOL aircraft **100** in the forward flight mode **206** and shows airflow

316 through the rotor units **116** during forward flight. As the operator directs, the VTOL aircraft **100** may transition from the hover mode **200** to the forward-flight mode **206**. The airflow **316** includes a boundary airflow having some laminar and some turbulent airflow. Various considerations may be employed to reduce turbulent airflow into the aft rotor unit **116(2)**. Vanes may be added to wings and/or the fuselage **102** (or other locations) to provide laminar airflow to the aft rotor unit **116(2)**. A dissipation mechanism may divert turbulent air away from the aft rotor unit **116(2)**.

In some embodiments, forward flight may be powered by a single rotor unit, such as the fore rotor unit **116(1)**, which may negate a desire to reduce turbulent airflow in some regions around the VTOL aircraft **100** during forward flight.

In the forward flight mode **206**, the rotor units **116** provide thrust that is directed substantially parallel to the flight path. The rotor units **116** may operate in a push-pull capacity, with the aft rotor unit **116(2)** pushing the aircraft forward, and the fore rotor unit **116(1)** pulling the aircraft forward. The forward-flight airflow generates a pressure differential between the top of the aircraft, fuselage and wings, and the bottom. The pressure differential creates the lift needed to keep the aircraft airborne, while the rotor units push and pull the air through to create thrust for forward movement. In various embodiments, the lift may be generated largely by the wings during flight in forward-flight mode **206** while the lift may be largely or solely generated by thrust of the rotor units **116** during flight in the hover mode **202**.

FIG. 4 is a top view of the illustrative VTOL aircraft **100** shown in FIG. 3B and shows the rotor units **116** in the hover mode **202**. The VTOL aircraft **100** is shown with the fore wing **122** as a canard wing and the aft wing **124** as a delta wing that is a main wing. The rotor units **116** are aligned with the longitudinal axis **118**. In some embodiments, the fore wing **122** may include the fore control surfaces **130** that rotate an entire portion of the fore wing. However, the fore wing **122** may employ traditional ailerons and/or other control surfaces, vanes, and/or other air directing features.

FIG. 5 is a top view of the illustrative VTOL aircraft shown in FIG. 1A. The VTOL aircraft **100** is shown with the rotor units **116** in the forward-flight mode **206**. The fore control surfaces **130** show a configuration with traditional ailerons.

FIG. 6A is a top view of the illustrative VTOL aircraft **100** shown in FIG. 3B and shows various components and compartments including control services and storage compartments. The VTOL aircraft **100** may include some or all of the features described below, in accordance with various embodiments.

The aft wing **124** may be a main wing and may provide a lifting surface during flight in the forward-flight mode **206**. The aft wing **124** may include ailerons **602**, which provide roll control during flight in the forward-flight mode **206** and possibly during flight in the transition mode **204**. In some embodiments, the aft wing **124** may include flaps or flaperons for speed and roll control during flight in the forward-flight mode **206** and possibly during flight in the transition mode **204**.

In some embodiments, the aft wing **124** may include wing tip thrusters **604** to provide roll stability during flight in the hover mode **202** and possibly during flight in the transition mode **204**. The wing tip thrusters **604** may comprise an exhaust connected to compressed air, which releases high pressure air downward, substantially perpendicular to the aft wing **124**. In some embodiments, the wing tip thrusters may be electrically driven rotors mounted in the aft wing **124** and/or possibly mounted on the fore wing **122**, which is described in more detail with reference to FIG. 16.

The aft wing **124** may include a storage compartment **606** for storing compressed air, extra batteries, hardware, personal items, and/or other payload. The aft wing **124** may comprise a hinge **608** that enables folding of the aft wing **124** during storage of the VTOL aircraft **100**. The hinge **608** may enable folding an outer section of the wing against or toward an inner section of the wing (or vertically) to reduce a width of the aft wing **124**. A folding mechanism **610** may be used to transition the wing from a folded position to a flight position (via rotation about the hinge **608**). The folding mechanism **610** may include a motor to aid in lifting the outer section of the aft wing **124**. The folding mechanism **610** may lock and unlock the aft wing **124**. The folding mechanism **610** may transmit a signal to indicate whether the aft wing **124** is locked or unlocked and/or folded or not folded. The hinge **608** and the folding mechanism **610** may be implemented on the fore wing **122**. For example, when the fore wing **122** is the main wing, then the hinge **608** and the folding mechanism may be located on the fore wing **122**.

In accordance with one or more embodiments, the VTOL aircraft **100** may include one or more stability augmentation sensors **612** that monitor a position, angle, acceleration, and/or orientation of a portion of the VTOL aircraft. For example, the stability augmentation sensors **612** may comprise gyroscopes and/or accelerometers that monitor the pitch, roll, and yaw of the VTOL aircraft **100**, and changes of each over time. The stability augmentation sensors **612** may provide input via signals to a control management system **614**.

The control management system **614** may process the signals from the stability augmentation sensors **612**, as well as input from an operator (pilot) via operator controls, to determine how to direct and power the rotor units **116** to maintain flight in the hover mode **202**, the transition mode **204**, and the forward-flight mode **206**. For example, the stability augmentation sensors **612** may detect a sudden tilt of the aircraft due to a gust of wind or other force exerted on the VTOL aircraft **100**. In response, the stability augmentation sensors **612** may transmit a signal to the control management system **614**. The control management system **614** may cause repositioning of one or more of the rotor units **116** to cause the one or more rotor units to direct a thrust to counter the force of the wind, etc., and thus stabilize flight of the VTOL aircraft **100**. Meanwhile, the control management system **614** may also process commands from the operator. The control management system **614** may prioritize control input from the stability augmentation sensors **612** and the operator to maintain stable flight. For example, when an operator provides a command that may compromise sustained flight, the control management system **614** may ignore the command and/or only execute the command for a limited duration before issuing another command (possibly in response to a signal from the stability augmentation sensors **612**) to take action to sustain flight.

The operator, using flight controls, sends input signals to the control management system **614**. In turn, the control management system receives the signals from the flight controls and/or the stability augmentation sensors **612**. The control management system **614** prioritizes the inputs from the stability augmentation sensors **612** and inputs from the operator and then adjusts a direction/orientation and/or power level of each rotor unit. The control management system **614** may also determine the position of the ailerons **602** and/or other control services for roll control during flight in the forward-flight mode **206** and possibly during flight in the transition mode **204**. However, in some embodiments, the ailerons **602** and/or other control services may be controlled mechanically, such as by use of cables and levers, and thus bypass use of the

control management system **614**. During flight in the hover mode **202**, the control management system **614** may send signals to the wing tip thrusters **604** to provide for directed thrust to cause or counter roll control.

The rotors **116** may be driven by electric motors **616** located at a hub of each of the rotors **116**. The electric motors **616** may be brushless magnet motors. The electric motors **616** may be powered by one or more battery in a battery set **618**. The battery set **618** may be implemented using one or more cells that are placed in one or more locations in the VTOL aircraft **100**. Placement of the battery or batteries may include consideration of a distribution of a payload such that the center of mass is substantially near a midpoint between the rotor units. Thus, the battery or batteries may be placed in other locations throughout the VTOL aircraft to distribute the weight of the battery or batteries. The battery **118** may be in fluid communication with a cooling duct **620**, which may pass external air and/or fluid past the battery **118** to reduce heat generated by the battery **118**. A wiring grid **622** may connect the battery set **618**, the control management system **614**, and a power management system **624**.

The power management system **624** may determine, monitor, and manage battery power of the battery set **618**. The power management system **624** may communicate battery power and/or other information to the control management system **614**, which may then use this information when determining how to control the VTOL aircraft (e.g., determining direction and amount of thrust, transmitting warning messages to an operator, causing and/or preventing modes of flight, etc.). For example, when the power management system **624** indicates that the battery power is depleted or close to being depleted (e.g., past a threshold amount), the control management system **614** may provide a signal to the operator to land the VTOL aircraft using an airstrip while sustaining flight in the forward-flight mode **206** because the battery set **618** may not be capable of powering the rotor units **116** to provide sustained flight in the hover mode **202**.

In some embodiments, the power management system **624** may provide for the operator to choose a power conservation mode, in which one rotor provides all of the thrust for the aircraft in a pull mode (e.g., the fore rotor unit **116(1)**) or a push mode (e.g., using the aft rotor unit **116(2)**).

FIG. 6B is a top view of the illustrative VTOL aircraft **100** shown in FIG. 6A and shows various components to provide reserve and/or emergency power. The various components may be selectively included and/or used to provide power to the electric motors **616** and/or charge the battery set **618**.

In accordance with some embodiments, the VTOL aircraft **100** may be equipped with solar cells **626** in communication with the power management system **624** via the wiring grid **622**. The solar cells **626** may enable charging the battery set **618** while the VTOL aircraft is in flight and/or while the VTOL aircraft **100** is not in flight (e.g., stored in a sunny spot, etc.). The solar cells **626** may be mounted on the main wings (e.g., the aft wing **124** in FIG. 6B). However, the solar cells **626** may be mounted on any surface of the VTOL aircraft **100**, or the solar cells (**709**) may be integrated in at least a portion of the skin of the VTOL aircraft **100**.

In various embodiments, the VTOL aircraft may include a drag alternator **628** that deploys a fan, blade, or wing. The fan, blade or wing may cause motion which may in turn cause the drag alternator to generate a current. The drag alternator **628** may be in communication with the battery **118** and the power management system **624** via the wiring grid **622**. The current generated by the drag alternator **628** may be used to charge the battery set **618**. The fan, blade, or wing of the drag alternator may be stored within the aircraft skin when not in use to

negate drag. Upon signal from the operator, the power management system 624, and/or the control management system 614, the fan, blade, or wing may be deployed to generate the current that may be converted to DC power to charge the battery set 618. Use of the drag alternator may be reserved to emergency situations where the VTOL aircraft is able to deploy the drag alternator 628 during glided flight or other situations where the additional drag from the fan, blade, or wing does not hinder flight of the VTOL aircraft 100.

FIG. 7 is a perspective view of a VTOL unmanned aerial vehicle (UAV) 700. The VTOL UAV 700 may include a recessed fuselage 702 located between one or more wings. In some embodiments, the VTOL UAV 700 may include a single wing 704 (e.g., an ovalar-shaped wing surrounding the recessed fuselage 702) and one or more stabilizers 706 to reduce aerodynamic side slip and increase directional stability in forward flight. However, the VTOL UAV 700 may only differ from the VTOL aircraft 100 in that the VTOL UAV 700 does not include a cockpit and operator controls located within the aircraft. The VTOL UAV 700 may include a control management system that may or may not receive input from an operator that is located remote from the VTOL UAV 700. The VTOL UAV 700 may include a monocoque structure, made of carbon fiber, titanium, aluminum, or any other material appropriate for an aircraft frame. In some embodiments, the structure may be a semi-monocoque design, with a shell and longerons made of carbon fiber, titanium, aluminum, or any other material appropriate for an aircraft frame. The skin is a low friction surface that may include built-in solar cells, as discussed above.

FIG. 8 is a top view of the illustrative VTOL UAV 700 shown in FIG. 7 and shows various components and compartments including locations of batteries and storage compartments. The VTOL UAV 700 includes the rotor units 116 that produce thrust for propulsion in a push-pull configuration. The rotor units 116 and/or other components may be configured in a similar manner as discussed above with reference to the VTOL aircraft 100. For example, the VTOL UAV 700 may include one or more of the wing tip thrusters 604, the stability augmentation sensors 612, the control management system 614, the electric motors 616, the battery set 618, the cooling duct 620, the wiring grid 622, the power management system 624, the solar cells 626, and/or the drag alternator 628.

In some embodiments, the VTOL UAV 700 may include surveillance and/or operational components 802, such as a plurality of cameras. For example, a camera may be located on the bottom of the fuselage and be capable of viewing objects, landscape, and so forth below the VTOL UAV 700. Another camera (or the same camera, may be able to view objects, landscape, and so forth in front of and/or behind the aircraft. Other cameras and/or surveillance components (e.g., radios, thermo sensors, etc.) may be employed by the VTOL UAV 700. The surveillance and/or operational components 802 may transmit signals to the operator or other person or device located remote from the VTOL UAV 700 via transmission of data using a radio, optics, or other transmission techniques.

FIG. 9A is a front elevation view of the illustrative VTOL aircraft 100 shown in FIG. 3B and shows the fore rotor 116(1) configured to provide thrust in a direction of the vertical axis 128 that bisects the fuselage 102 in symmetrical halves. Thrust from the fore rotor unit 116(1) is directed substantially parallel to the vertical axis 128.

FIG. 9B is a front elevation view of the illustrative VTOL aircraft 100 shown in FIG. 9A and shows the fore rotor 116(1) configured to provide thrust in a direction having an angle α_1 between a fore rotor unit thrust axis 902 and the vertical axis

128 that bisects the aircraft in symmetrical halves. The rotor unit thrust axis 902 is parallel to a direction of thrust generated by the fore rotor unit 116(1). The aft rotor 116(2) may be configured to provide thrust in a direction having an angle α_2 between an aft rotor unit thrust axis 904 and the vertical axis 128. As discussed above, the control management system 614 may cause the rotor units to move via the rotating chassis 120 to provide stabilized flight in response to signals from the stability augmentation sensors 612 and/or inputs from an operator. Thus, the rotor units 116 may move independently of one another and under control of the control management system 614 to maintain flight of the VTOL aircraft 100. The freedom of movement of the rotor units described herein aids in maintaining stable flight in the hover mode 202.

FIG. 9C shows the rotor units rotated negatively beyond 90 degrees to rapidly slow the aircraft prior to landing. In this configuration, the thrust generated from the rotor units is directed in the direction of flight, thereby slowing the forward airspeed of the aircraft.

FIG. 10 is a partial top view of the illustrative VTOL aircraft 100 shown in FIG. 1A and shows the fore rotor 116(1) configured to provide directed thrust in a direction between an angle 13 between the fore rotor unit thrust axis 1002 and the longitudinal axis 118 of the fuselage 102. As discussed above, the control management system 614 may cause the rotor units to move via the rotating chassis 120 to provide directed thrust in response to signals from the stability augmentation sensors 612 and/or inputs from an operator. Thus, the rotor units 116 may move independently of one another and under control of the control management system 614 to maintain flight of the VTOL aircraft 100. The freedom of movement of the rotor units described herein allows for directed thrust laterally during flight in the forward-flight mode 206 and possibly during flight in the transition mode 204.

FIGS. 11A-11C are isometric views of an illustrative rotating assembly 1100 that moveably couples a rotor unit to the fuselage 102 of the illustrative VTOL aircraft 100.

FIG. 11A shows the illustrative rotating assembly 1100 including a rotor 1102 with an electric motor 1104 located at the center of the rotor unit 1102. The rotor 1102 is mounted in a rotating chassis 1106, which allows rotation about its lateral and longitudinal axes. The rotating chassis 1106 may include an inner frame 1110 connected to a beam 1108 (e.g., stator), which supports the rotor 1102 and the electric motor 1104. The dashed line depicts the rotor unit in the transition mode 204.

FIG. 11B shows the illustrative rotating assembly 1100 with an outer frame 1112 supporting the inner frame 1110. The outer frame 1112 and the inner frame 1110 are rotatable with respect to each other about the longitudinal and lateral axes, as shown in FIG. 11C. The fuselage 102 of the VTOL aircraft 100 may provide the outer frame 1112, or the outer frame 1112 may be coupled to the fuselage 102. In some embodiments, the rotating chassis may be a gimbaled chassis and/or a pivoting chassis.

FIGS. 12A-12C are isometric views of an illustrative mechanism 1200 to cause movement of the rotor 1102 via the rotating assembly 1100 in accordance the FIGS. 9B and 10.

FIG. 12A shows a first drive assembly 1202 that includes a first motor 1204 and a gear 1206 that causes movement of the rotor unit 1102. The first drive assembly 1202 may be under control of the control management system 614, which may selectively power the first motor 1204 in either direction to cause transition of the rotor 1102 about a first axis (e.g., such as the transition shown in FIG. 9B and FIG. 10). The first drive assembly 1202 may include the inner frame 1110 described with reference to the rotating assembly 1100.

13

A second drive assembly **1208** may include a second motor **1210** and pulley **1212** that causes movement of the rotor **1102** for tilt control along an axis. The second drive assembly **1208** may be under control of the control management system **614**, which may selectively power the second motor **1210** in either direction to cause transition of the rotor unit **1102** about a second axis (e.g., such as the transition shown in FIG. 3A). The second drive assembly **1208** may include the inner frame **1110** described with reference to the rotating assembly **1100**. FIG. 12b shows a configuration that includes multiple instances of the mechanism **1200**, such as a first mechanism **1214** and a second mechanism **1216**. FIG. 12C shows the illustrative mechanism **1200** within the fuselage **102** of the VTOL aircraft **100**.

FIG. 13A is a partial cutout isometric view of an illustrative rotor unit **1300**. The rotor unit **1300** (also referred to herein as a rotor and/or the rotor units **116**) includes a rotor vane **1302**, a stator **1304**, and an electric motor **1306**. In some embodiments, the rotor unit **1300** may include a duct **1308**, which may be a housing that directs airflow through and from the rotor unit **1300**. The rotor vane **1302** may be rotated by the electric motor **1306**, and pulls air through the rotor unit to produce thrust. As the air flows through the rotor unit vane **1302**, a rotation is imparted on the air in the duct **1308**. The stator **1304** couples the rotor unit vane **1302** and electric motor **1306** to the duct **1308** (which also acts as a housing).

guide vanes may be arranged radially within each duct, and actuated to direct thrust

In some embodiments, the stator **1304** may include curved blades that provide structural support and act as a straightening vane. The straightening vane includes blades that are pitched in a direction opposite to the blades of the rotor unit vane **1302**. The opposite direction of the pitched blades of the straightening vane reduces the rotation imparted on the air by the rotor unit vane **1302**; thereby resulting in exhaust air that is substantially less turbulent than without use of the straightening vane. However, a second vane **1302(2)** may be rotatable and a separate part from the stator **1304**. In some embodiments, the rotor unit **1300** may be a non-ducted rotor unit and may not include the duct **1308**.

FIG. 13B is a side elevation view of the illustrative rotor unit **1300**. The electric motor **1306** may be housed between a fore cone **1310** and an aft cone **1316**, which is located on the side of the rotor unit that exhausts the thrust of air. The fore cone **1310** and the aft cone **1316** are aerodynamic features that reduce drag caused by the rotor unit **1300** during flight of the VTOL aircraft **100**. The fore and aft cones may be ventilated to improve motor cooling.

FIG. 14 is a side elevation view of an illustrative multi-vane rotor unit **1400**. The multi-vane rotor unit **1400** may include a fore rotor vane **1302(1)** and an aft rotor vane **1302(2)**, a fore stator **1304(1)** and an aft stator **1304(2)**, and a fore motor **1306(1)** and an aft motor **1306(2)**. In some embodiments, the fore motor **1306(1)** and the aft motor **1306(2)** may cause rotation of the respective rotor unit vanes in opposite directions. The fore stator **1304(1)** may include straight blades while the aft stator **1304(2)** may be a straightening vane and may include blades curved opposite the curvature of the blades of the rotor unit vane **1302(2)**. When more than one rotor vane is in each duct, rotors may rotate in opposite directions to counter vortex effect, and improve efficiency.

FIGS. 15A and 15B are partial cutout isometric views of the illustrative rotor unit shown in FIG. 13 and show thrust directing apparatuses. FIG. 15A shows the rotor unit **1300** with a rotating inner duct **1502** that is rotatably coupled to the inner duct. FIG. 15B shows the rotor unit **1300** with a rotating vane **1504** that is rotatably coupled to the inner duct. The

14

rotating inner ring **1502** and the rotating vane **1504** may provide yaw and roll control during VTOL and horizontal flight in the forward-flight mode **206** and the transition mode **204**, and may provide yaw and roll control during flight in the hover mode **202**. During flight in the forward flight mode **206**, the ailerons (or other control surfaces) may control yaw and roll.

FIG. 16 is a top view of an illustrative VTOL aircraft **100** that includes wing tip rotors **1602**. The wing tip rotors **1602** may provide roll stability during flight in the hover mode **202** and possibly during flight in the transition mode **204**. The wing tip rotors **1602** may be located near a tip of the main wing. However, the wing tip rotors **1602** may be located in other locations to direct thrust outward towards the general direction of the wing tips and/or downward from the wingtips.

The wing tip rotors **1602** may be smaller sized rotors than the main rotors **116** described above. The wing tip rotors **1602** may also be thinner than the main rotors **116** such that a profile of the wing tip rotors does not project substantially above a top surface of the wing or below a bottom surface of the wing. In some embodiments, the wing tip rotors may not include the rotating chassis **120** and therefore may not be able to move to direct thrust in different directions. However, the wing tip rotors **1602** may be configured to include directional mechanisms, such as the rotating chassis **120**, the rotating inner duct **1502**, and/or the rotating vane **1504**.

In the hover mode, the thrust from the main rotor units **116** is directed down, allowing for the VTOL aircraft **100** to hover, both in and out of ground effect. The control management system **614** may vary the rotor speed in the hover mode **202** in order to maintain a level, balanced hover. The control management system **614** may also send signals to the rotor units **116**, directing the rotor units **116** to move slightly about the longitudinal and lateral axes to maintain a stable hover, or to move the VTOL aircraft **100** forward, aft, or laterally. Wing tip rotors **1602** may be controlled by the control management system **614** and may aid the main rotor units **116** in lift and in hover stability.

The wing tip rotors **1602** may generate thrust perpendicular to the VTOL aircraft **100** at varying intervals as necessary to maintain a stable hover. The power output of the wing tip rotors **1602** may be determined by the control management system **614**. In some embodiments, the wing tip rotors may include a cover that can be placed over the wing tip rotors **1602** during flight in the forward-flight mode **206** to reduce drag caused by the wing tip rotors **1602**. The wing tip rotors **1602** may have a cover on the top side and the bottom side of the wing which opens below a certain airspeed. The cover may be substantially flush with the aircraft skin in order to decrease drag during flight in the forward-flight mode **206** and the transition mode **204**.

FIGS. 17-25B show various configurations of VTOL aircraft that utilize the rotor units **116** configured substantially as described above. The VTOL aircraft shown and described below may be implemented with an on-board operator (pilot) and/or in a UAV configuration that may or may not include a cockpit.

FIG. 17 is a top view of an illustrative VTOL aircraft **1700** having a shortened fuselage and rotor units of differing sizes selected to balance a payload of the VTOL aircraft **1700** is located closer to the aft end **106**, then the aft rotor unit **116(2)** may be a larger or more powerful rotor unit than the fore rotor unit **116(1)** to enable stable flight in the hover mode **202**. The larger rotor unit may produce more thrust at the same revolution-per-minute speed. The VTOL aircraft **1700**

15

may have a stronger push-type thrust from the aft rotor unit 116(2) when the aft rotor unit is the larger rotor unit.

The VTOL aircraft 1700 may include shortened fuselage 1702 as compared to the fuselage 102 depicted in the VTOL aircraft 100 shown in FIG. 1. The shortened fuselage 1702 may allow for increased dissipation of airflow from the fore rotor unit 116(1) resulting in increased efficiency of the aft rotor unit 116(2).

FIG. 18 is a top view of an illustrative VTOL aircraft 1800 having a traditional wing configuration. The VTOL aircraft 1800 includes two lift generating surfaces, a fore wing 1802 and an aft wing 1804. The fore wing 1802 provides the majority of the lift for the aircraft. The fore wing 1802 has ailerons 1806, which allow the operator to maneuver the aircraft about the longitudinal axis. The aft wing 1804 acts as a lifting surface and provides pitch stability. The aft wing 1804 has elevators 1808, which allow the operator to maneuver the aircraft about the lateral axis, to pitch up and down.

The VTOL aircraft 1800 has two rotor units mounted in a rotating chassis along a longitudinal axis of a fuselage 1810. In this embodiment, the fore rotor unit 116(1) has a larger diameter than the aft rotor unit 116(1). The larger rotor unit may produce more thrust at the same revolution-per-minute speed. The configuration show in FIG. 18 may result in a stronger pull-type thrust from the fore rotor unit 116(1).

The VTOL aircraft 1800 may include shortened fuselage 1810 as compared to the fuselage 102 depicted in the VTOL aircraft 100 shown in FIG. 1. The shortened fuselage 1810 may allow for increased dissipation of airflow from the fore rotor unit 116(1) resulting in increased efficiency of the aft rotor unit 116(2).

FIG. 19 is a top view of an illustrative VTOL aircraft 1900 where the fore rotor is located between the aft rotor and a cockpit. The cockpit 112, when included, may be located forward of the fore rotor unit 116(1). In some embodiments, the cockpit 112 may be located behind the aft rotor 116(2), which may be another alternative configuration.

FIG. 20 is a top view of an illustrative multi-occupant VTOL aircraft 2000. The multi-occupant VTOL aircraft 2000 may effectively have two fuselages 2002 with a fore end and an aft end, two main wings, and two rotor units 116. The fuselages 2002 may be configured substantially parallel to each other, and may be large enough to hold passengers or other payload. The two fuselages 2002 may be coupled by an aerodynamic strut 2004 in substantially the center of mass of the aircraft, and between the fore and aft rotor units.

FIGS. 21A and 21B are side elevation views of another illustrative multi-occupant VTOL aircraft 2100. FIG. 21A shows the multi-occupant VTOL aircraft 2100 in the hover mode 202. FIG. 21B shows the multi-occupant VTOL aircraft 2100 in the forward-flight mode 206. The multi-occupant VTOL aircraft 2100 may include a single fuselage 2102 that may be used to transport passenger or payload. The VTOL aircraft 2100 may use gas powered engines 2104 to generate thrust, such as gas powered turbo propellers, jet turbines, and/or other non-electric power plants.

FIGS. 22A and 22B are top views of an illustrative VTOL aircraft 2200 where the operator 2202 straddles a fuselage 2204. FIG. 22A shows the VTOL aircraft 2200 in flight in the hover mode 202. The VTOL aircraft 2200 may include two wings 2206, the rotor units 116, and a windshield 2208. The fuselage 2204 may be shaped to accommodate an operator situated above the fuselage akin to an operator straddling a frame while seated on a motorcycle. The wings 2206 may provide lift while the VTOL aircraft 2200 is in flight in the forward-flight mode 206. FIG. 22B shows the VTOL aircraft 2200 in flight in the forward-flight mode 206.

16

The windshield 2208 may protect the operator from wind, debris, or any other object in the air. The windshield 2208 may be large enough to protect the operator's torso and head. In some embodiments, the windshield 2208 may shield the operator's entire body. The windshield 2208 may be made out of acrylic, plastic, glass, or any other transparent material. The windshield 2208 may be formed from a shatterproof material.

With reference to FIG. 22B, the operator 2202 may control the VTOL aircraft 2200 from a seated position near the center of the fuselage 2204. The fuselage 2204 may include a seat 2214 and foot rests 2216 for the operator. The operator 2202 may issue control commands to the VTOL aircraft 2200 with handlebars 2218, similar to motorcycle handlebars. The handlebar 2218 may include a throttle, through which the operator 2202 may change the power output of the rotor units 116. In some embodiments, the operator 2202 may issue the control commands using a lever (e.g., joystick), a steering wheel, or any other device capable of transmitting the operator's desired power and direction of the VTOL aircraft 2200. The mechanical motion of the handlebars 2218 may be transmitted into an electronic signal by the control management system 614. The control management system 614 may process signals from an operator and the plurality of stability augmentation sensors 612, and send an output signal to each rotor unit 116, directing the rotor units to independently to move about the longitudinal axis and the lateral axis as necessary to transition from the hover mode 202 (FIG. 22A) to the forward-flight mode 206 (FIG. 22B). The control management system 614 may also receive an input signal from the throttle. The speed of each rotor unit 116 may be determined by operator input through the throttle, and stability augmentation sensor 612 input mixed in the computer management system 614. The rotor units 116 may produce enough lift to maintain a hover in and out of ground effect.

FIGS. 22C and 22D are side elevation views of an illustrative VTOL aircraft. FIG. 22C shows airflow 2210 through the rotor units 116 during flight in the hover mode 202. FIG. 22D shows airflow 2212 through the rotor units 116 and across the VTOL aircraft 2200 during flight in the forward-flight mode 206. In some embodiments, during forward flight, the backwash from the forward rotor unit(s) may provide enhanced lifting ability of the by directing a majority of the fore rotor unit's backwash over the upper surfaces, creating a lower pressure area relative to the lower surfaces.

FIGS. 23A and 23B are side elevation views of an illustrative VTOL aircraft 2300 and show mounting arms 2302 that connect the rotor units 116 to the fuselage 2304.

The rotor units 116 may be moveably coupled to the fuselage 2304 via the mounting arms 2302 that include the rotating chassis 120 and mounting arms 2302. The rotating chassis 120 may allow for freedom of movement about the longitudinal axis of each rotor unit, while the mounting arms 2302 provide the transition from a hover mode 202 as shown in FIG. 23A, to a forward-flight mode 206 as shown in FIG. 23B. In some embodiments, the mounting arm 2302 may move the thrust and backwash at least partially away from the fuselage 2304. For example, the air received by the aft rotor unit 116(2) may not flow directly from the fore rotor unit 116(1) since the rotor units 116 may be located on different planes due to use of the mounting arms 2302. In some embodiments, the mounting arms 2302 may be "L" shaped or have other configurations, including structural supports or wings.

FIGS. 24A and 24B are top views of an illustrative VTOL aircraft 2400 and show a cluster of rotor units. The VTOL aircraft may include one or more clusters 2402 of rotor units. In some embodiments, the cluster 2402 may include rotor

17

units aligned along a longitudinal axis of the fuselage. This configuration may result in displacement of the rotor units in the forward flight mode 206, which causes the rotor units to move above or below the fuselage after rotation and thereby receive cleaner intake air. However, other configurations of the cluster 2402 may be used. The cluster 2402 may be used for the aft rotor units as shown in FIG. 24A, for the fore rotor units as shown in FIG. 24B, or in both the fore rotor units and aft rotor units. The rotor units selected for inclusion in the cluster 2402 may be selected to balance power based on a location of a center of mass of the VTOL aircraft 2400.

FIGS. 25A and 25B are top views of an illustrative VTOL aircraft 2500 using non-ducted rotors 2502. The non-ducted rotors 2502 may be similar or the same as conventional propeller blades. In some instances, the blades of the non-ducted rotors 2502 may be feathered or otherwise adjusted to change an angle of the blades relative to a drive shaft.

FIG. 26 is a side elevation view of another aircraft 2600 using rotor units coupled to a rotatable arm 2602. The rotor units 116 may be moveably coupled to the fuselage 2604 via the rotatable arm 2602 having a pivot location 2606. The rotatable arm 2602 may enable the transition from the hover mode 202 to a forward-flight mode 206 by rotation of the rotatable arm 2602. In some embodiments, the rotatable arm 2602 may move the thrust and backwash at least partially away from the fuselage 2604.

CONCLUSION

Although the subject matter has been described in language specific to structural features and/or methodological acts, it is to be understood that the subject matter defined in the appended claims is not necessarily limited to the specific features or acts described. Rather, the specific features and acts are disclosed as illustrative forms of implementing the claims.

What is claimed is:

1. A vertical takeoff and landing (VTOL) aircraft comprising:

- a fuselage having a fore end, an aft end, a top side, and a bottom side;
- a main wing coupled to the fuselage;
- at least one vertical stabilizer coupled to the fuselage;
- a fore rotor unit located at the fore end of the fuselage and intersecting a longitudinal axis of the fuselage;
- an aft rotor unit located at the aft end of the fuselage and intersecting the longitudinal axis of the fuselage, the fore rotor unit and the aft rotor unit each including:
 - a ducted housing including a stator;
 - at least one rotor vane including a plurality of pitched blades;
 - an electric motor coupled to the stator, the electric motor to rotate the at least one rotor vane to create thrust;
- a rotating support for coupling each ducted housing to the fuselage, the rotating support allowing rotation of each rotor unit about at least one axis, the rotating support configured to transition each rotor unit between:
 - a hover flight orientation such that thrust from each rotor unit is directed substantially perpendicular to the longitudinal axis, the thrust from each rotor unit generating lift to support the VTOL aircraft in hover flight, and
 - a forward flight orientation such that thrust from each rotor unit is directed substantially parallel to the longitudinal axis, the thrust from each rotor unit causing propulsion of the VTOL aircraft in forward flight; and
 - a battery set to provide power for each electric motor.

18

2. The VTOL aircraft as recited in claim 1, wherein the rotating support provides a lateral directing of the rotor unit's thrust to enable roll and yaw control while hovering, and yaw control during forward flight.

3. The VTOL aircraft as recited in claim 1, wherein a height of pressure centers of the rotor units is above a center of mass of the aircraft while hovering to provide stability via a pendulum effect.

4. The VTOL aircraft as recited in claim 1, wherein the main wing provides upward lift to support flight while the VTOL aircraft is moving in a forward direction.

5. The VTOL aircraft as recited in claim 1, further comprising:

- a plurality of stability augmentation sensors located on the VTOL aircraft, the plurality of stability augmentation sensors to generate signals that include motion and orientation information during operation of the VTOL aircraft; and

- a control management system to receive the signals from at least the plurality of stability augmentation sensors, the control management system to issue commands to orient and power the fore rotor unit and aft rotor unit based at least in part on the inputs from the stability augmentation sensors.

6. The VTOL aircraft as recited in claim 1, further comprising a power management system to monitor power capacity of the battery set.

7. The VTOL aircraft as recited in claim 1, wherein the main wing further comprises:

- a fixed wing section coupled to the aft end of the fuselage;
- a foldable wing section rotatably coupled to the fixed wing section; and

- a folding mechanism located between the fixed wing section and the foldable wing section to transition the foldable wing section from a folded state to an extended state that provides lift during forward flight.

8. The VTOL aircraft as recited in claim 1, further comprising a cockpit that includes operator controls that, when manipulated by an operator, adjust power and orientation of the fore rotor unit and the aft rotor unit.

9. A vertical takeoff and landing (VTOL) aircraft comprising:

- a fuselage having a fore end and an aft end;

- a main wing having a fore end, an aft end, a lateral axis extending between tips of the main wing, a longitudinal axis perpendicular to the lateral axis and extending between the fore end and the aft end, a top side, and a bottom side;

- a fore rotor unit located at the fore end of the fuselage and intersecting a longitudinal axis of the fuselage;

- an aft rotor unit located at the aft end of the fuselage and intersecting the longitudinal axis of the fuselage, the fore rotor unit and the aft rotor unit each including:

- a ducted housing;

- at least one rotor vane including a plurality of pitched blades; and

- a motor coupled to a stator, the motor to rotate the at least one rotor vane to create thrust;

- a rotating support for coupling the housing to at least the one of the fuselage or the main wing, the rotating support allowing rotation of each rotor unit about at least the lateral axis, the rotating support configured to transition each rotor unit between:

- a hover flight orientation such that thrust from each rotor unit is directed substantially perpendicular to the lon-

19

longitudinal axis, the thrust from each rotor unit gener-
 ating lift to support the VTOL aircraft in hover flight,
 and
 a forward flight orientation such that thrust from each
 rotor unit is directed substantially parallel to the longi- 5
 tudinal axis, the thrust from each rotor unit causing
 propulsion of the VTOL aircraft in forward flight; and
 a power distribution system in communication with each
 motor to deliver power for flight.
10. The VTOL aircraft as recited in claim 9, wherein the
 rotating support orients each rotor unit such that thrust from 10
 the rotors is directed substantially parallel to the longitudinal
 axis, the thrust from the rotors causing propulsion of the
 VTOL aircraft in forward flight, and wherein a wing provides
 upward lift during forward flight.
11. The VTOL aircraft as recited in claim 9, wherein the
 main wing provides upward lift during the forward flight.
12. The VTOL aircraft as recited in claim 9, further com-
 prising a regenerative battery charging system that, when 20
 activated, converts air drag of at least one rotor unit into an
 electrical charging current for a battery set while the main
 wing provides upward lift to support forward flight of the
 VTOL aircraft.
13. The VTOL aircraft as recited in claim 9, further com-
 prising one or more cameras that transmit imagery to an 25
 operator of the VTOL aircraft.
14. A vertical take-off and landing (VTOL) aircraft com-
 prising:
 a fuselage having a fore end and an aft end;
 a wing coupled to the fuselage, the wing to generate lift 30
 when the VTOL aircraft is in forward flight;
 at least one fore rotor unit and at least one aft rotor unit
 intersecting a longitudinal axis of the fuselage, the fore
 rotor unit and aft rotor unit each including a rotor vane
 that generates thrust; 35
 a motor for each rotor vane to rotate the respective rotor
 vane;
 a power source to provide power to each motor;
 a mounting surface located at the fore end and the aft end of
 the fuselage, the mounting surface for coupling the fore 40
 rotor unit and the aft rotor unit to the fuselage, and for

20

independently rotating the fore rotor and the aft rotor
 about at least one axis, wherein the mounting surface is
 configured to rotationally transition each rotor unit
 between:
 a hover mode where each rotor unit is oriented such that
 thrust from each rotor unit is directed substantially
 perpendicular to the longitudinal axis, the thrust from
 each rotor unit generating lift to support the VTOL
 aircraft in hover flight, and
 a forward flight mode where each rotor unit is oriented
 such that thrust from each rotor unit is directed sub-
 stantially parallel to the longitudinal axis, the thrust
 from each rotor unit causing propulsion of the VTOL
 aircraft in forward flight, and wherein the wing pro-
 vides upward lift during the forward flight; and
 a control processor, the control processor for processing a
 plurality of inputs and sending an output signal to con-
 trol power and orientation of the fore rotor unit and the
 aft rotor unit.
15. The VTOL aircraft as recited in claim 14, wherein the
 mounting surface is further configured to orient each rotor
 unit in a transition mode where each rotor unit is oriented in
 a position between the hover mode and the forward flight
 mode, the thrust from each rotor unit generating lift to support
 the VTOL aircraft and to cause propulsion of the VTOL in
 forward flight.
16. The VTOL aircraft as recited in claim 14, further com-
 prising a plurality of stability augmentation sensors located
 on the VTOL aircraft, the plurality of stability augmentation
 sensors to generate signals that include motion and orienta-
 tion information during operation of the VTOL aircraft, and
 wherein the control processor uses the signals from the plu-
 rality of stability augmentation sensors to generate the output
 signal to control power and orientation of the fore rotor unit
 and the aft rotor unit.
17. The VTOL aircraft as recited in claim 14, wherein the
 power source includes a battery set, and wherein at least one
 wing, the fuselage, or both, include solar cells to provide
 current to recharge the battery set.

* * * * *