



US010615496B1

(12) **United States Patent**  
**Zeppettella**

(10) **Patent No.:** **US 10,615,496 B1**  
(45) **Date of Patent:** **Apr. 7, 2020**

(54) **NESTED SPLIT CRESCENT DIPOLE ANTENNA**

6,342,867 B1 1/2002 Bell  
6,384,790 B2 5/2002 Dishart et al.  
6,529,170 B1 3/2003 Nishizawa et al.  
6,828,947 B2 12/2004 Apostolos et al.  
6,853,342 B2 2/2005 Podger  
6,879,291 B2 4/2005 Duxbury et al.

(Continued)

(71) Applicant: **Government of the United States, as represented by the Secretary of the Air Force**, Wright-Patterson AFB, OH (US)

(72) Inventor: **David L. Zeppettella**, Centerville, OH (US)

FOREIGN PATENT DOCUMENTS

EP 1071161 B1 10/2003  
WO 2017100126 A1 6/2017

(\* ) Notice: Subject to any disclaimer, the term of this patent is extended or adjusted under 35 U.S.C. 154(b) by 80 days.

OTHER PUBLICATIONS

Azenui, N. et al., "A Printed Crescent Patch Antenna for Ultrawideband Applications," IEEE Antennas and Wireless Propagation Letters, vol. 6, 2007, pp. 113-116.

(Continued)

(21) Appl. No.: **15/915,706**

(22) Filed: **Mar. 8, 2018**

Primary Examiner — Hoang V Nguyen

(74) Attorney, Agent, or Firm — AFMCLO/JAZ; Matthew Fair

(51) **Int. Cl.**

**H01Q 9/28** (2006.01)  
**H01Q 9/16** (2006.01)  
**H01Q 3/01** (2006.01)  
**H01Q 1/28** (2006.01)

(52) **U.S. Cl.**

CPC ..... **H01Q 3/01** (2013.01); **H01Q 9/16** (2013.01); **H01Q 9/28** (2013.01); **H01Q 1/28** (2013.01)

(58) **Field of Classification Search**

CPC ..... H01Q 3/01; H01Q 9/065; H01Q 9/16; H01Q 9/28; H01Q 9/285  
See application file for complete search history.

(57)

**ABSTRACT**

An antenna including a crescent-shaped antenna body having a plurality of crescent-shaped arms with crescent-shaped notched ends; and a connector positioned on a substantially non-jagged portion of the crescent-shaped antenna body to receive input energy, wherein the antenna body operates in a continuous frequency band of operation. The antenna body may transmit an omni-directional output beam. The antenna body may be structurally conformable. The antenna body may be configured to attach to flexible surfaces. The antenna body may be configured to attach to non-planar surfaces. The continuous frequency band of operation may include approximately 165 MHz to 1.35 GHz. The antenna body may be configured to have an average voltage standing wave ratio of approximately 1.72:1 across the continuous frequency band of operation.

(56) **References Cited**

U.S. PATENT DOCUMENTS

3,573,834 A \* 4/1971 McCabe ..... H01Q 13/18 343/769  
5,173,715 A 10/1992 Rodal et al.  
5,418,544 A 5/1995 Elliot  
5,745,079 A 4/1998 Wang et al.  
5,874,919 A 2/1999 Rawnick et al.

**9 Claims, 11 Drawing Sheets**

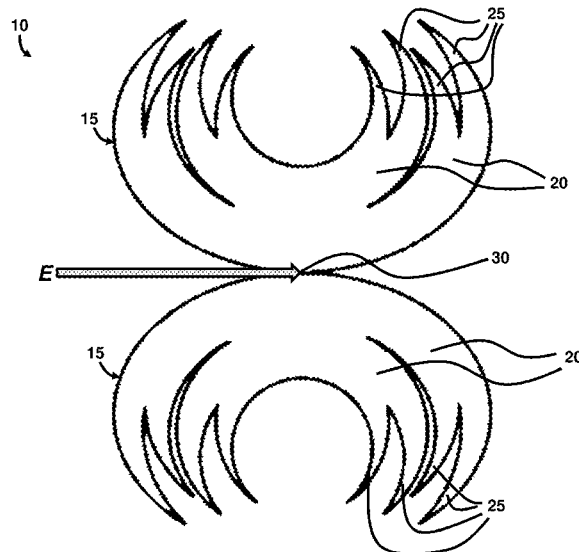

(56)

**References Cited**

U.S. PATENT DOCUMENTS

7,015,868	B2	3/2006	Puente Baliarde et al.	
7,148,850	B2	12/2006	Puente Baliarda et al.	
7,170,461	B2	1/2007	Parsche	
7,193,575	B2	3/2007	Mohammadian	
7,583,236	B1	9/2009	Lopez	
7,598,867	B2	10/2009	Carrender	
7,839,347	B2*	11/2010	Schneider	H01Q 19/10 343/741
8,855,730	B2	10/2014	Sanford	
8,994,600	B2*	3/2015	Schneider	H01Q 19/10 343/741
9,000,991	B2	4/2015	Ramberg et al.	
2003/0098814	A1	5/2003	Keller et al.	
2005/0162332	A1*	7/2005	Schantz	H01Q 13/10 343/795
2012/0062433	A1	3/2012	Balanis et al.	
2012/0068898	A1	3/2012	Clow et al.	
2012/0092220	A1	4/2012	Tani et al.	

OTHER PUBLICATIONS

Liang, Q., "Nested Array for Antenna Deployment in Massive MIMO with Spectrum Efficiency," 2016 IEEE International Con-

ference on Mobile Services, San Francisco, CA, Jun. 27-Jul. 2, 2016, pp. 196-199.

DeNoia, V., et al., "Input impedance behavior of a planar elliptical ring dipole antenna," Antennas and Propagation Society International Symposium (APSURSI), 2012 IEEE, Chicago, IL, Jul. 8-14, 2012, 2 pages.

Irani, K., et al., "Semi-Elliptical Dipole Antenna for RF Energy Scavenging," Antennas and Propagation (ISAP), 2015 International Symposium, Hobart, TAS, Australia, Nov. 9-12, 2015, 4 pages.

Nazli, H., et al., "An Improved Design of Planar Elliptical Dipole Antenna for UWB Applications," IEEE Antennas and Wireless Propagation Letters, vol. 9, Mar. 29, 2010, pp. 264-267.

Obsiye, A., et al., "Modified Printed Crescent Patch Antenna for Ultrawideband RFID (UWB-RFID) Tag," 2008 IEEE International RF and Microwave Conference Proceedings, Kuala Lumpur, Malaysia, Dec. 2-4, 2008, 3 pages.

Sallam, M., et al., "2.4/5 GHz WLAN crescent antenna on flexible substrate," 2016 10th European Conference on Antennas and Propagation (EuCAP), Davos, Switzerland, Apr. 10-15, 2016, 3 pages.

Schantz, H., "Planar Elliptical Element Ultra-Wideband Dipole Antennas," Antennas and Propagation Society International Symposium, IEEE, San Antonio, TX, Jun. 16-21, 2002, pp. 44-47.

Yu, J., et al., "Study of an Ultra Wideband Planar Elliptical Dipole Antenna," International Conference on Microwave Technology and Computational Electromagnetics, ICMTCE, Beijing, China, Nov. 3-6, 2009, pp. 49-52.

\* cited by examiner

FIG. 1

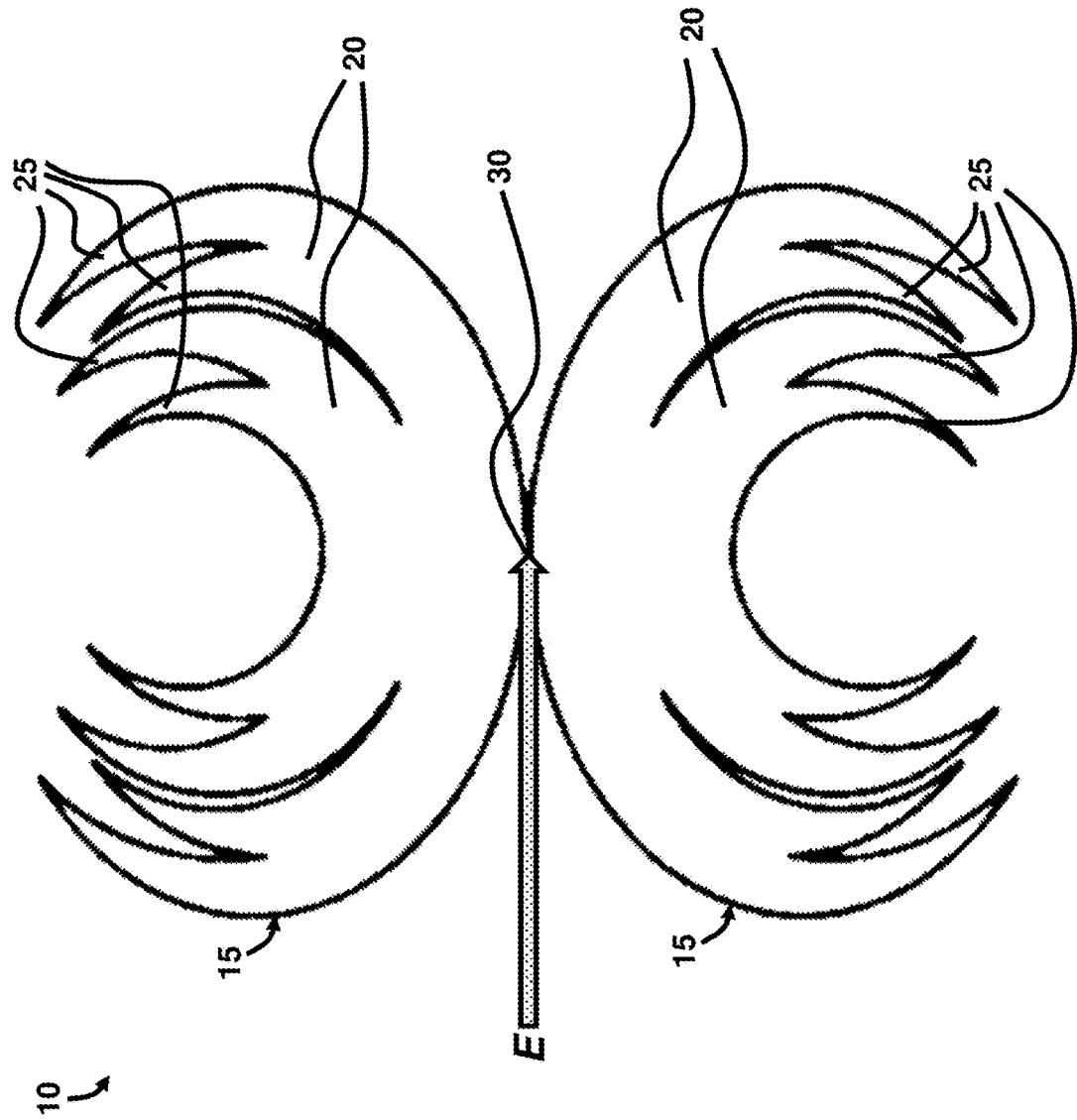

**FIG. 2A**

Elevation  
Radiation Beam Pattern

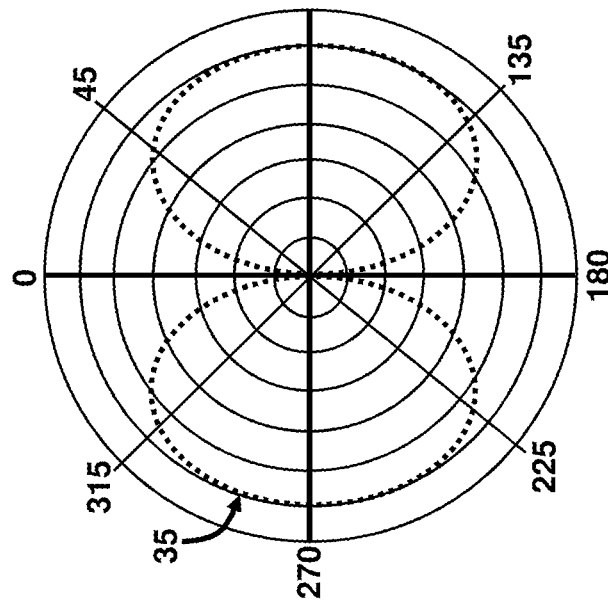

**FIG. 2B**

Azimuth  
Radiation Beam Pattern

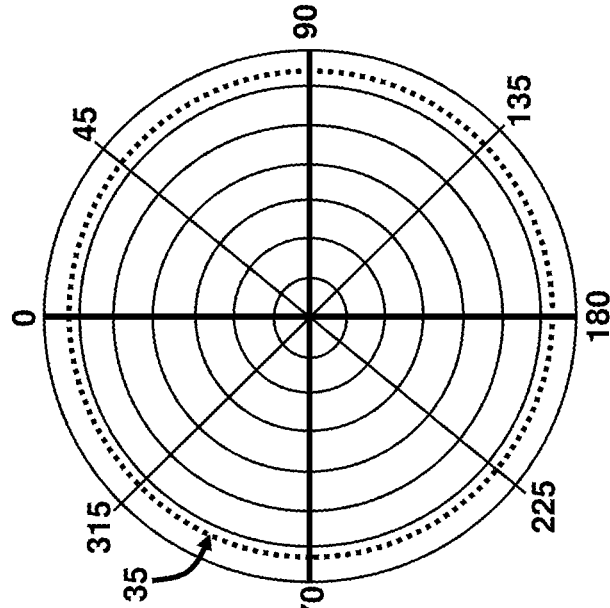

**FIG. 2C**

3D Radiation Beam Pattern  
(165 MHz)

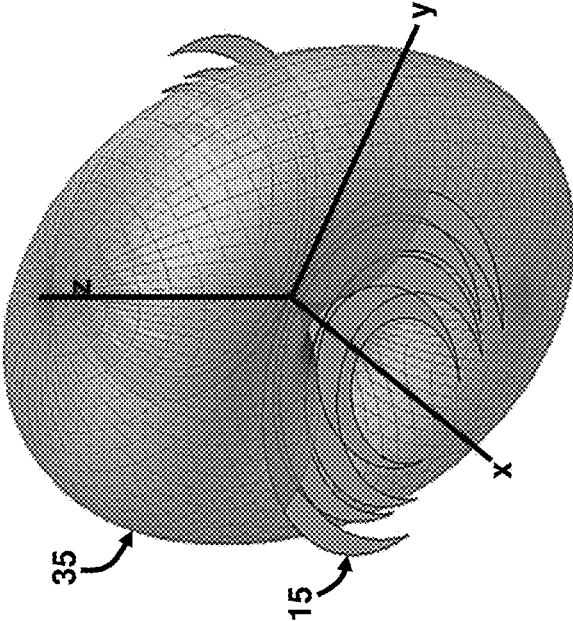

**FIG. 2D**

3D Radiation Beam Pattern  
(300 MHz)

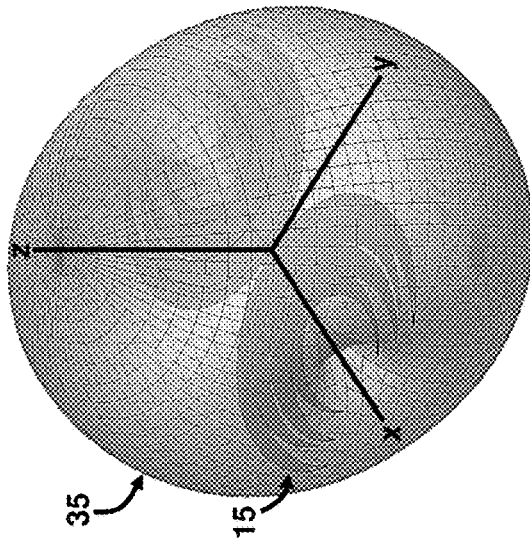

**FIG. 2E**

3D Radiation Beam Pattern  
(800 MHz)

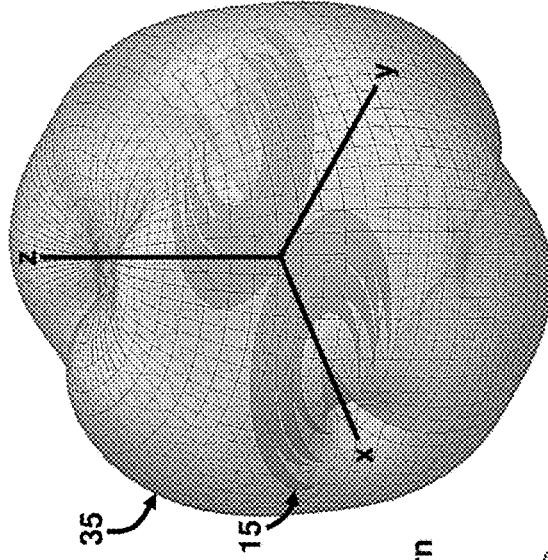

**FIG. 2F**

3D Radiation Beam Pattern  
(1.3 GHz)

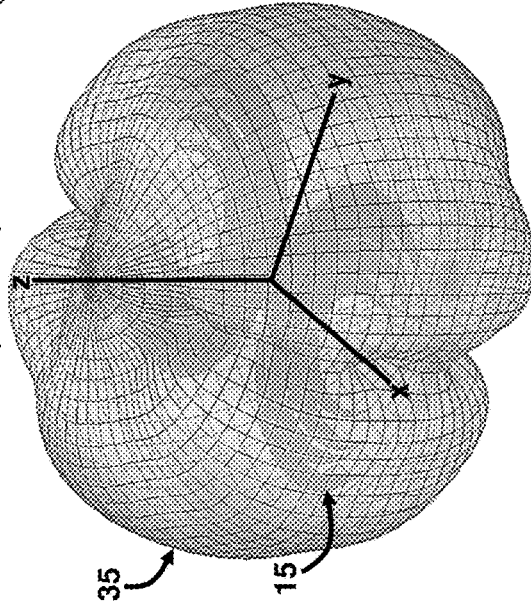

FIG. 3A

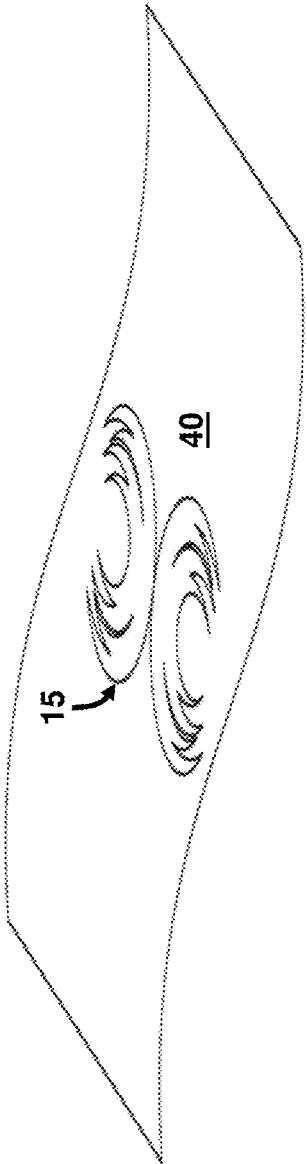

FIG. 4

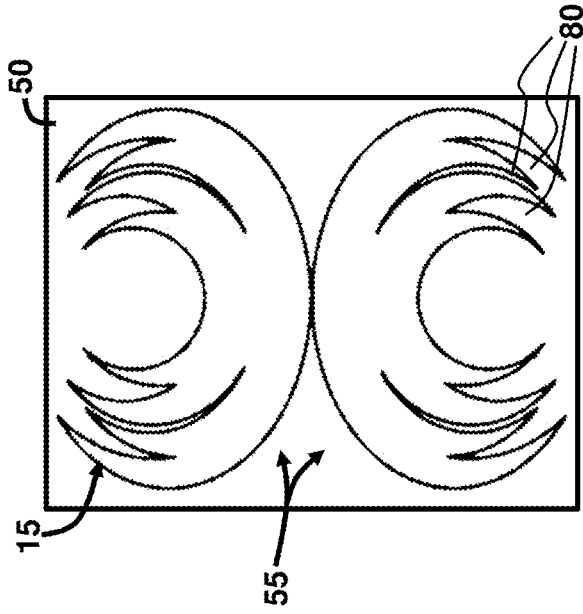
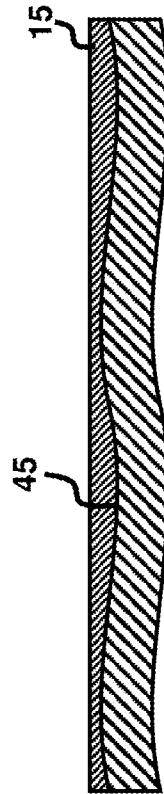

FIG. 3B



**FIG. 5**

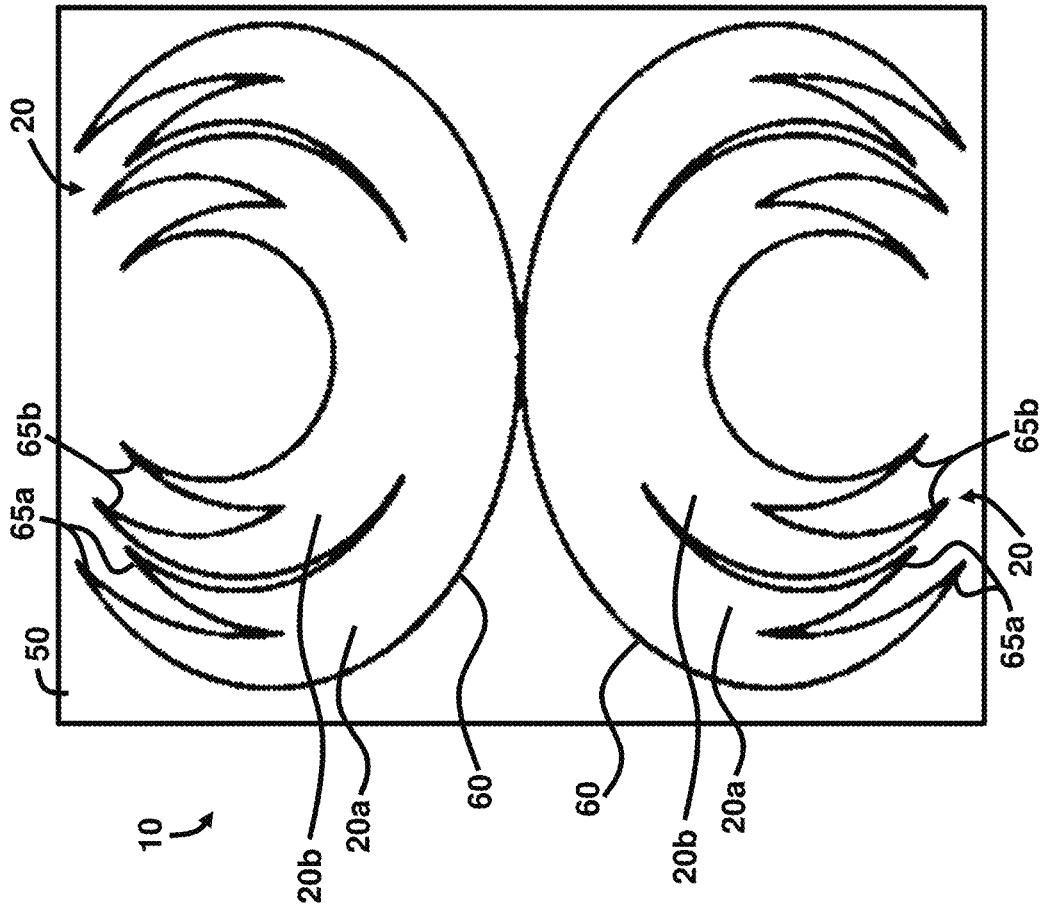
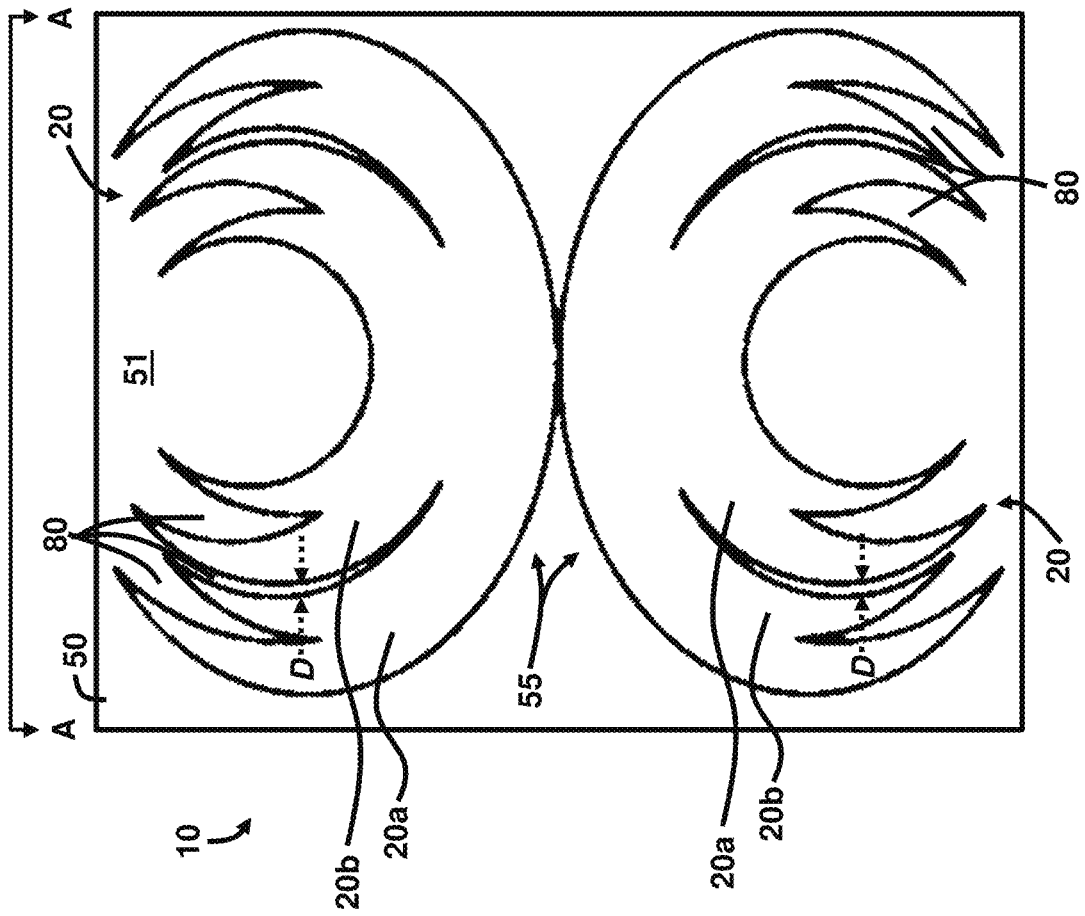
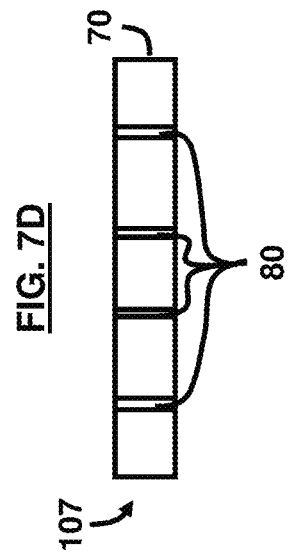
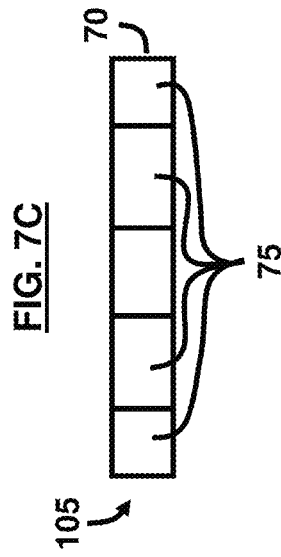
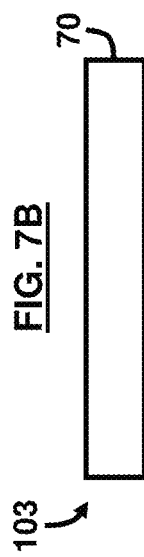
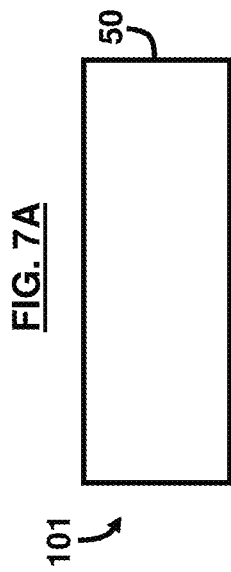
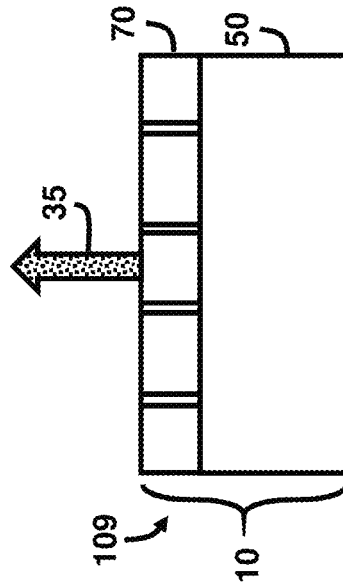
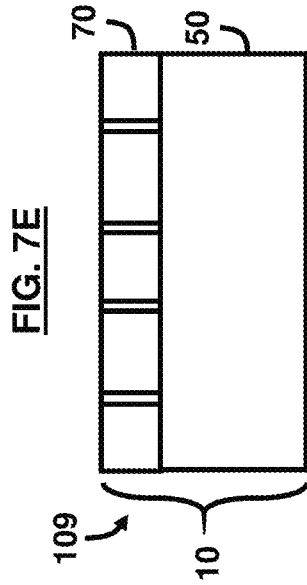

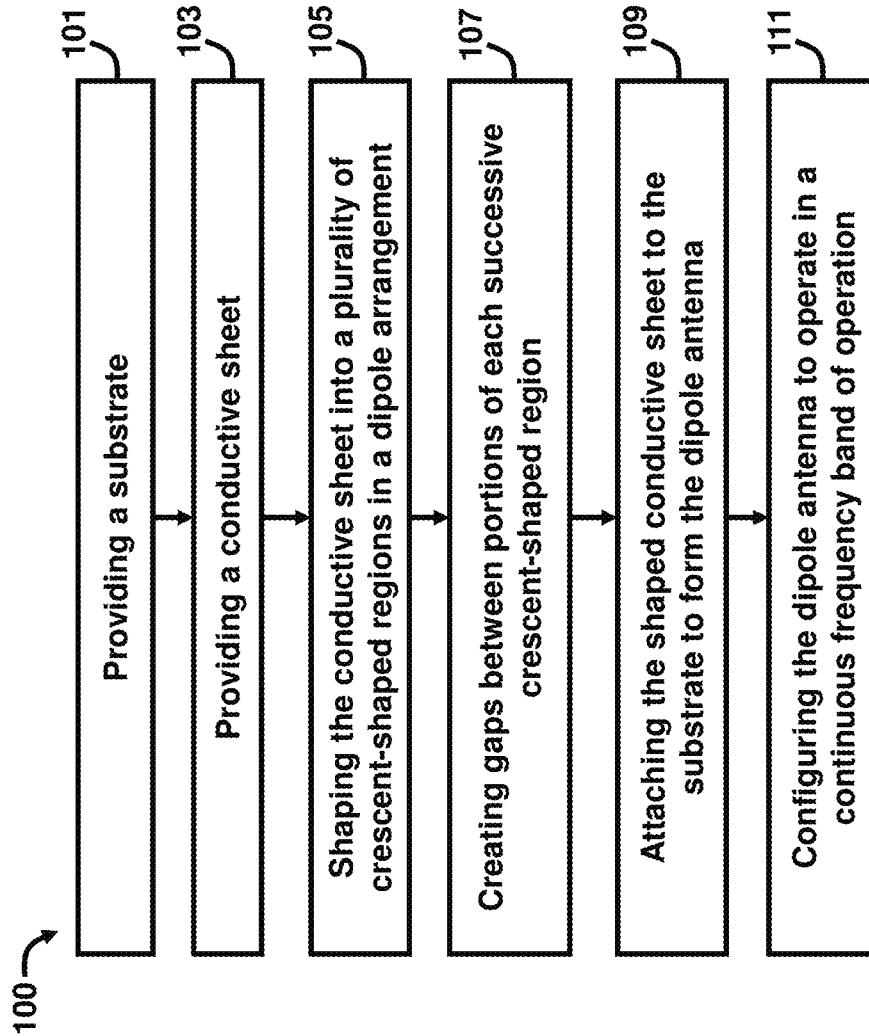

FIG. 6





**FIG. 8**



**FIG. 9**

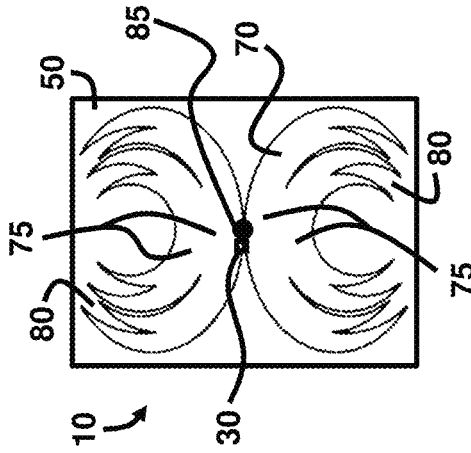

FIG. 10

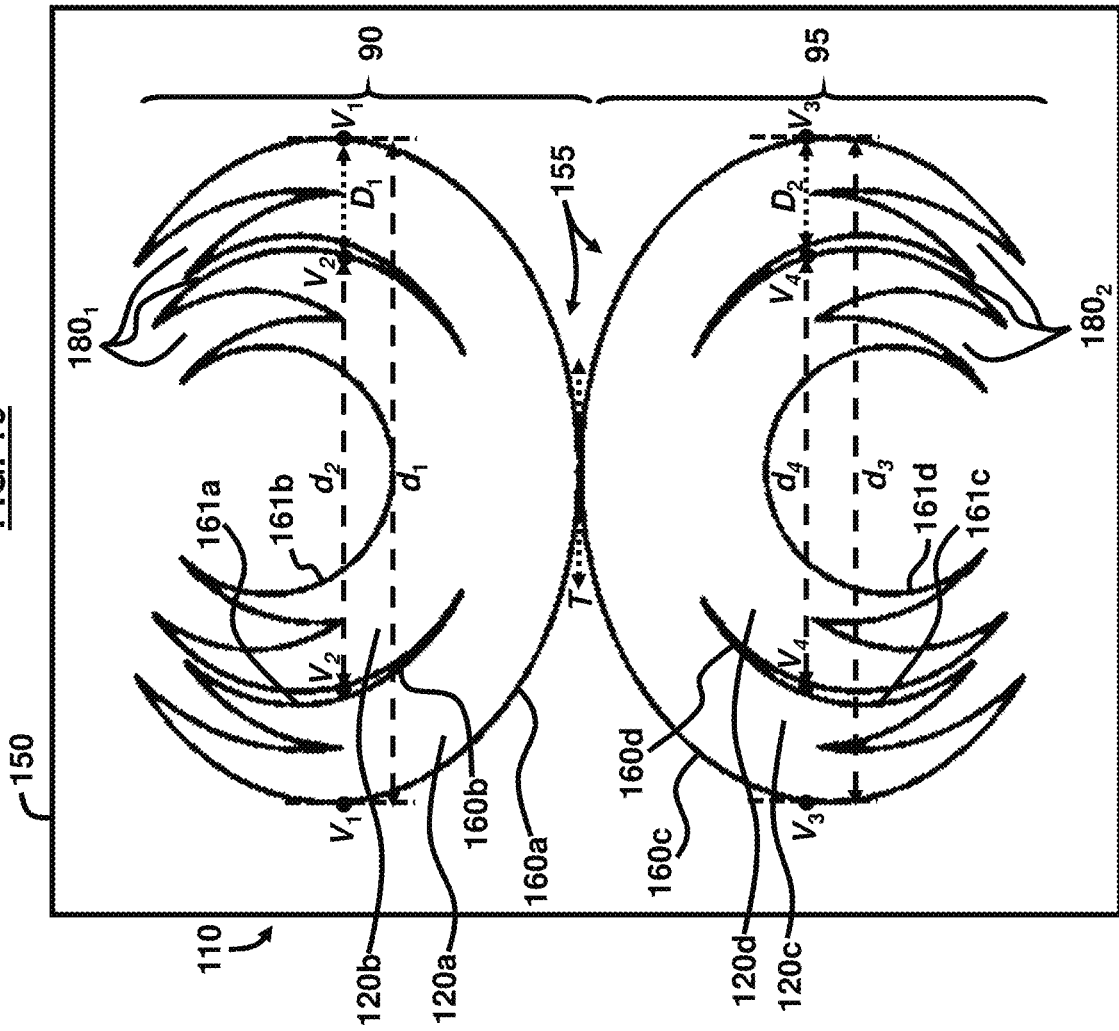
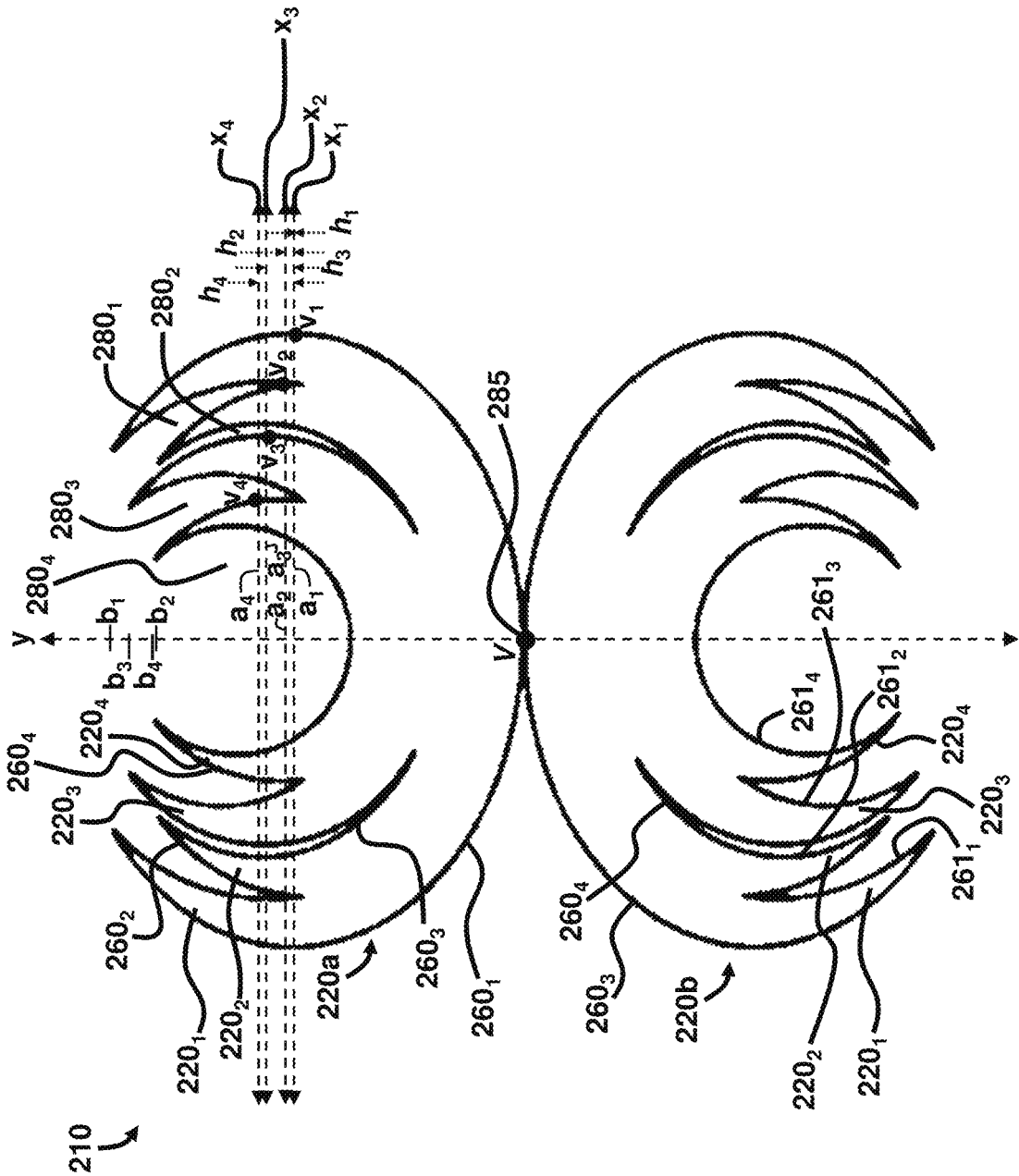

FIG. 11



1

## NESTED SPLIT CRESCENT DIPOLE ANTENNA

### GOVERNMENT INTEREST

The invention described herein may be manufactured and used by or for the Government of the United States for all government purposes without the payment of any royalty.

### BACKGROUND

#### Field of the Invention

The embodiments herein generally relate to antennas, and more particularly to dipole antennas.

#### Background of the Invention

Antennas can generally be categorized as directional antennas and omni-directional antennas. Directional antennas typically focus a beam in one direction while an omni-directional antenna radiates power uniformly over 360° in a single plane. The choice of the type of antenna to use is typically based on the application, signal requirements, and location. The use of conformal and load-bearing antennas in polymer composite structures has been proposed as a means of addressing the space and weight constraints associated with autonomous and remotely piloted aircraft. Moreover, at a very high frequency (VHF) and a lower ultra high frequency (UHF), the size of the antenna becomes large and conformal application on curved surfaces, such as aircraft, becomes difficult. As such, although the use of self-complementary geometry (such as a pair of ellipses or disks) is well-known to provide ultra wideband (UWB) antenna performance, the required antenna size at VHF frequencies combined with the solid nature of the geometric shape presents difficulty in either allowing a flexible surface to change shape or attaching the geometry to a complex shape.

### BRIEF SUMMARY OF THE INVENTION

In view of the foregoing, an embodiment herein provides an antenna comprising a crescent-shaped antenna body comprising a plurality of crescent-shaped arms having crescent-shaped notched ends; and a connector positioned on a substantially non-jagged portion of the crescent-shaped antenna body to receive input energy, wherein the antenna body operates in a continuous frequency band of operation. The antenna body may transmit an omni-directional output beam. The antenna body may be structurally conformable. The antenna body may be configured to attach to flexible surfaces. The antenna body may be configured to attach to non-planar surfaces. The continuous frequency band of operation may comprise approximately 165 MHz to 1.35 GHz. The antenna body may be configured to have an average voltage standing wave ratio of approximately 1.72:1 across the continuous frequency band of operation. The antenna body may be comprised of a foam substrate and is configured to have an average voltage standing wave ratio of approximately 1.85:1 across the continuous frequency band of operation. The antenna body may comprise a dipole configuration.

Another embodiment provides a dipole antenna comprise a substrate; and a pair of antenna arms, wherein each pair of antenna arms comprises a first crescent-shaped arm configured on the substrate and comprising a convex outer edge and a first set of tapered notched ends; and a second

2

crescent-shaped arm configured on the substrate, contacting the first crescent-shaped arm, and comprising a second set of tapered notched ends, wherein the second crescent-shaped arm is smaller in size than the first crescent-shaped arm, and wherein each of the first crescent-shaped arms of the pair of antenna arms contact each other on the convex outer edge. A separation distance between each of the first and second crescent-shaped arms may be a function of a dielectric constant of the substrate. A separation distance between each of the first and second crescent-shaped arms may be approximately 2 mm. The pair of antenna arms may form a symmetrical arrangement.

Another embodiment provides a method of forming a dipole antenna, the method comprising providing a substrate; providing a conductive sheet; shaping the conductive sheet into a plurality of crescent-shaped regions in a dipole arrangement; creating gaps between portions of each successive crescent-shaped region; attaching the shaped conductive sheet to the substrate to form the dipole antenna; and configuring the dipole antenna to operate in a continuous frequency band of operation. The method may comprise shaping the conductive sheet using a photoetching process. The method may comprise machining the conductive sheet from a predetermined material. The predetermined material may comprise flexible graphite. The predetermined material may comprise expanded metal. The method may comprise positioning an input power feed point on the dipole antenna; and attaching a radio frequency connector at the input power feed point of the dipole antenna. The method may comprise configuring a thickness and material composition of the dipole antenna such that that dipole antenna is structurally conformable.

These and other aspects of the embodiments herein will be better appreciated and understood when considered in conjunction with the following description and the accompanying drawings. It should be understood, however, that the following descriptions, while indicating preferred embodiments and numerous specific details thereof, are given by way of illustration and not of limitation. Many changes and modifications may be made within the scope of the embodiments herein without departing from the spirit thereof, and the embodiments herein include all such modifications.

### BRIEF DESCRIPTION OF THE DRAWINGS

The embodiments herein will be better understood from the following detailed description with reference to the drawings, in which:

FIG. 1 is a schematic diagram illustrating an antenna, according to an embodiment herein;

FIG. 2A is a schematic diagram illustrating the elevation radiation beam pattern associated with the antenna of FIG. 1, according to an embodiment herein;

FIG. 2B is a schematic diagram illustrating the azimuth radiation beam patterns associated with the antenna of FIG. 1, according to an embodiment herein;

FIG. 2C is a schematic diagram illustrating the three-dimensional radiation beam pattern associated with the antenna of FIG. 1 at 165 MHz, according to an embodiment herein;

FIG. 2D is a schematic diagram illustrating the three-dimensional radiation beam pattern associated with the antenna of FIG. 1 at 300 MHz, according to an embodiment herein;

FIG. 2E is a schematic diagram illustrating the three-dimensional radiation beam pattern associated with the antenna of FIG. 1 at 800 MHz, according to an embodiment herein;

FIG. 2F is a schematic diagram illustrating the three-dimensional radiation beam pattern associated with the antenna of FIG. 1 at 1.3 GHz, according to an embodiment herein;

FIG. 3A is a schematic diagram illustrating an antenna body attached to a flexible surface, according to an embodiment herein;

FIG. 3B is a cross-sectional diagram illustrating an antenna body attached to a non-planar surface, according to an embodiment herein;

FIG. 4 is a schematic diagram illustrating an antenna in a dipole configuration and attached to a substrate, according to an embodiment herein;

FIG. 5 is a schematic diagram illustrating a dipole antenna with notched ends, according to an embodiment herein;

FIG. 6 is a schematic diagram illustrating a dipole antenna with gaps between antenna arms, according to an embodiment herein;

FIG. 7A is a schematic diagram illustrating a first step in a process for manufacturing a dipole antenna, according to an embodiment herein;

FIG. 7B is a schematic diagram illustrating a second step in a process for manufacturing a dipole antenna, according to an embodiment herein;

FIG. 7C is a schematic diagram illustrating a third step in a process for manufacturing a dipole antenna, according to an embodiment herein;

FIG. 7D is a schematic diagram illustrating a fourth step in a process for manufacturing a dipole antenna, according to an embodiment herein;

FIG. 7E is a schematic diagram illustrating a fifth step in a process for manufacturing a dipole antenna, according to an embodiment herein;

FIG. 7F is a schematic diagram illustrating use of a dipole antenna, according to an embodiment herein;

FIG. 8 is a flow diagram illustrating a method of forming a dipole antenna, according to an embodiment herein;

FIG. 9 is a schematic diagram illustrating a dipole antenna with a connector, according to an embodiment herein;

FIG. 10 is a schematic diagram illustrating a dipole antenna depicting vertices of the crescent-shaped arms, according to an embodiment herein; and

FIG. 11 is a schematic diagram illustrating a dipole antenna depicting the various axes of the crescent-shaped arms, according to an embodiment herein.

#### DETAILED DESCRIPTION OF THE INVENTION

Embodiments of the disclosed invention, its various features and the advantageous details thereof, are explained more fully with reference to the non-limiting embodiments that are illustrated in the accompanying drawings and detailed in the following description. Descriptions of well-known components and processing techniques are omitted to not unnecessarily obscure what is being disclosed. Examples may be provided and when so provided are intended merely to facilitate an understanding of the ways in which the invention may be practiced and to further enable those of skill in the art to practice its various embodiments. Accordingly, examples should not be construed as limiting the scope of what is disclosed and otherwise claimed.

In the drawings, the size and relative sizes of layers and regions may be exaggerated for clarity. The embodiments herein provide a dipole antenna configured with a series of crescent-shaped arms with gaps/notches in between portions of the arms. The shape of the antenna arms together with the gaps/notches allows the antenna to be attached to complex, non-planar, or curved underlying surfaces such as an aircraft's wings. The complete dipole antenna is formed by placing a second arm, identical to the first arm, in a mirror image position across a line tangent to the inflection point of the convex side on large crescent of the first arm. The crescent-shaped arms are positioned adjacent to one another with the successive arms being smaller than the preceding arms. A mirror image of the crescent-shaped arms with gaps is provided to create a dipole antenna configuration. The antenna is an ultra-wide band dipole antenna that has an 8:1 bandwidth ratio beginning at approximately 165 MHz up to approximately 1.35 GHz and operates in a continuous frequency band. The antenna has an average voltage standing wave ratio of 1.72:1 across the continuous operating frequency band. The antenna is non-fractal and is an omnidirectional antenna. Referring now to the drawings, and more particularly to FIGS. 1 through 11, where similar reference characters denote corresponding features consistently throughout, there are shown exemplary embodiments.

FIG. 1 illustrates an antenna 10 comprising a crescent-shaped antenna body 15 comprising a plurality of crescent-shaped arms 20 having crescent-shaped notched ends 25. The crescent-shaped arms 20 are one continuous structure in one example, or may be discontinuous structures that are electrically connected to each other, in another example. The crescent-shaped notched ends 25 provide both electrical (e.g., current flow) and mechanical (e.g., structural flexing) functions. A connector 30 is positioned on a substantially non-jagged portion of the crescent-shaped antenna body 15 to receive input energy E and to drive the electrical signals of the antenna 10, wherein the antenna body 15 operates in a continuous frequency band of operation, as opposed to a fractal frequency band of operation. The continuous frequency band of operation is provided by inputting the energy E on the smooth portion (i.e., location of the connector 30) of the crescent-shaped antenna body 15. The number of crescent-shaped arms 20 may be selected based on the desired bandwidth of the antenna 10. Generally, the more arms 20, the greater the bandwidth.

In an example, the arms 20 are conductive and may comprise copper or flexible graphite. The antenna body 15 may be structurally conformable or flexing, wherein the crescent-shaped notched ends 25 permit the antenna body 15 to be shape-changing. The connector 30 is configured as an electrical connector that is operable at radio frequencies in the multi-megahertz range. In an example, the connector 30 may be a coaxial radio frequency (RF) connector, wherein a coaxial cable (not shown) may be connected to the connector 30.

As shown in FIGS. 2A through 2C, with reference to FIG. 1, the antenna body 15 may transmit an omni-directional output beam 35. In a two-dimensional view, the omni-directional output beam 35 is shown in a polar format; with the elevation radiation beam pattern shown in FIG. 2A, and the azimuth radiation beam pattern shown in FIG. 2B. Generally, the omni-directional output beam 35 is substantially doughnut-shaped when viewed as a three-dimensional (3D) radiation beam pattern at 165 MHz, as shown in FIG. 2C. The radiation or antenna pattern typically describes the relative strength of the radiated electric field in various directions from the antenna body 15 at a constant distance.

In an example, the gain of the omni-directional antenna **10** may be increased by narrowing the beamwidth (e.g., the angular aperture where the main/significant power is radiated from the antenna **10**) in the vertical or elevation plane, which focuses the energy of the antenna **10** toward the horizon. The radiation beam pattern changes based on the frequency of operation of the antenna **10**. FIGS. 2D through 2F, with reference to FIGS. 1 through 2C, depict example 3D radiation beam patterns associated with the omni-directional output beam **35** from the antenna body **15**, at 300 MHz, 800 MHz, and 1.3 GHz, respectively. As shown in FIGS. 2D through 2F, the conductive geometry of the radiation beam patterns become significantly larger than a wavelength as frequency increases, which aligns with expected patterns characteristic of wideband antennas, and which further reveals the proper operability of the antenna **10**. The operational band is determined by the physical size of the geometry of the antenna **10**. For example, if the dimensions of the antenna **10** are scaled by a factor of  $\frac{1}{6}$ , the antenna **10** operates from about 1 GHz to 8 GHz and has a footprint of approximately 8 cm $\times$ 11 cm.

The antenna body **15** is structurally conformable in that it is able to attach to an underlying surface by adapting the shape/configuration of the antenna body **15** to align with the shape/configuration of the underlying surface. In other words, the antenna body **15** is capable of shape-changing. The configuration of the crescent-shaped arms **20** with the crescent-shaped notched ends **25** permits this conformable, shape-changing functionality. In an example, the antenna body **15** may be configured to attach to flexible surfaces **40** as shown in FIG. 3A, with reference to FIGS. 1 through 2F. In another example, the antenna body **15** may be configured to attach to non-planar surfaces **45** as shown in the cross-sectional diagram of FIG. 3B, with reference to FIGS. 1 through 3A. As indicated in FIG. 3B, the antenna body **15** shape-changes to match the corresponding shape of the underlying non-planar surface **45** without any gaps, voids, or spaces between the antenna body **15** and the non-planar surface **45**.

In an example, the continuous frequency band of operation may comprise approximately 165 MHz to 1.35 GHz. The antenna body **15** may be configured to have an average voltage standing wave ratio (VSWR) of approximately 1.72:1 across the continuous frequency band of operation. The VSWR indicates the quality of the impedance match of the antenna **10**. A high VSWR is an indication that power that could potentially go into the radiation pattern **35** is reflected back along a feed cable instead of being radiated by the antenna **10**. In an example, a VSWR of 2.0:1 or less is considered acceptable in accordance with the embodiments herein.

As shown in FIG. 4, with reference to FIGS. 1 through 3B, the antenna body **15** is configured on a substrate **50**. The type of substrate **50** will impact VSWR. For example, a FR4 circuit board may be considered, wherein the FR4 circuit board is a flame retardant, fiberglass-reinforced epoxy laminate printed circuit board containing a thin layer of copper foil laminated to one or both sides of a fiberglass epoxy material. A FR4 circuit board with a relative permittivity (i.e., dielectric constant ( $\epsilon_r$ ))=4.4 and a dielectric loss tangent ( $\tan \delta$ )=0.01 results in average VSWR=1.72:1; while, in an example, the substrate **50** may comprise foam, which approaches the dielectric properties of air, with  $\epsilon_r \sim 1$ , and results in an average VSWR=1.85:1. The dielectric loss tangent ( $\tan \delta$ ) refers to the dissipation of electromagnetic energy (i.e., heat) of the dielectric material of the substrate **50**. As such, the antenna body **15** may be comprised of a

foam substrate **50** and is configured to have an average voltage standing wave ratio of approximately 1.85:1 across the continuous frequency band of operation. As further illustrated in FIG. 4, the antenna body **15** may comprise a dipole configuration **55**.

In an example, the aggregate shape of the arms **20** can be photo-etched from a copper sheet using any of laser and chemical cutting of the copper sheet to form the desired shaped of the arms **20**. Alternatively, the arms **20** could be cut from a copper sheet using computer-aided machine tools. The arms **20** are then attached to a substrate **50** that could be either a flexible material or a dielectric composite structure. The method of attachment is governed by the intended substrate **50**. In the case of structural composites, the arms **20** can be included in the lay-up process to form a stack of materials constituting the arms **20**, and the resin used to bind the plies together also bonds the antenna **10** to the surface of the underlying component.

The shape of both arms **20** in each dipole shape may be considered as four partially overlapped crescent shapes of different sizes. The process of forming these shapes is the same as for creating a lune in planar geometry. Each of the crescent-shaped arms **20** is derived through the reduction in the area of an ellipse by subtracting the area of a partially overlapping ellipse of the same or slightly smaller size. Each of the three smaller crescent shapes is offset some distance from the convex side of the largest crescent which, when combined with the varying radii of the underlying elliptical geometry, creates notched ends **25** of different sizes that extend down into the antenna arms **20**. From a mechanical perspective, these notched ends **25** allow the antenna **10** to conform to complex surfaces and flexible substrates **50**. Electrically, the notched ends **25** act in conjunction with each gap **80** between the arms **20** to establish antenna input impedance and also serve to suppress lateral current flow that typically degrades antenna performance. The notched ends **25** may be formed using laser etching patterning techniques followed by a chemical etching process in an appropriate solution.

In an example, the antenna **10** may be used on aircraft such as manned or unmanned aircraft systems. Furthermore, such use may be in either commercial or military aircraft. Moreover, the conformal antenna **10** provided by the embodiments herein may be used for composite aircraft structures to enhance radio communications in the upper VHF and lower UHF bands. More particularly, the antenna **10** may be used on aircraft that are constructed of dielectric structural composites or have structural components constructed of such materials. Some examples of such components include fuselage, vertical stabilizers, and winglets. Alternate applications include installation of the antenna **10** on conformal surfaces of watercraft with dielectric structures or as a portable antenna for remote ground stations where the reduced surface area of the antenna **10** decreases the wind loading on the antenna **10**.

FIG. 5, with reference to FIGS. 1 through 4, illustrates the dipole antenna **10** comprising a substrate **50**. A pair of antenna arms **20** is also provided, wherein each pair of antenna arms **20** comprises a first crescent-shaped arm **20a** configured on the substrate **50** and comprising a convex outer edge **60** and a first set of tapered notched ends **65a**; and a second crescent-shaped arm **20b** configured on the substrate **50**, contacting the first crescent-shaped arm **20a**, and comprising a second set of tapered notched ends **65b**, wherein the second crescent-shaped arm **20b** is smaller in size than the first crescent-shaped arm **20a**, and wherein



each of the first crescent-shaped arms **20a** of the pair of antenna arms **20** contact each other on the convex outer edge **60**.

As shown in FIG. 6, with reference to FIGS. 1 through 5, a separation distance  $D$  between each of the first and second crescent-shaped arms **20a**, **20b** may be a function of a dielectric constant of the substrate **50**. The separation distance  $D$  between each of the first and second crescent-shaped arms **20a**, **20b** may be approximately 2 mm, in an example. The pair of antenna arms **20** (arms **20a**, **20b**) may form a symmetrical arrangement, however the embodiments herein are not restricted to a symmetrical arrangement.

The embodiments herein enable an ultra-wideband VHF/UHF antenna **10** to be conformally integrated with a dielectric surface **51** of a substrate **50** that either is flexible or has a fixed, complex curvature. In contrast to the conventional antenna solutions, the antenna **10** provided by the embodiments herein enables shape change (e.g., is structurally conformal) and integration with complex underlying shapes through a reduction of antenna surface area brought about by the introduction of the notched ends **25** and cut-outs (i.e., gaps **80**). Specifically, the conformal, UWB VHF/UHF antenna **10** may be used on flexible surfaces **40** (as shown in FIG. 3A) and complex shapes including non-planar surfaces **45** (as shown in FIG. 3B) and achieves a 40% reduction in antenna surface area compared to conventional dipole antennas, and without a loss of impedance bandwidth.

FIGS. 7A through 7E, with reference to FIGS. 1 through 6, are successive manufacturing steps of forming a dipole antenna **10**. FIG. 7F, with reference to FIGS. 1 through 7E, illustrates use of the dipole antenna **10**, according to an embodiment. The views depicted in FIGS. 7A through 7F are taken along the line A-A in FIG. 6. FIG. 8, with reference to FIGS. 1 through 7F, is a flow diagram illustrating the manufacturing method **100** depicted in in FIGS. 7A through 7F. The method **100** comprises providing (101) a substrate **50**, as shown in FIG. 7A; providing (103) a conductive sheet **70**, as shown in FIG. 7B; shaping (105) the conductive sheet **70** into a plurality of crescent-shaped regions **75** in a dipole arrangement (e.g., dipole configuration **55**), as shown in FIG. 7C; creating (107) gaps **80** between portions of each successive crescent-shaped region **75**, as shown in FIG. 7D; attaching (109) the shaped conductive sheet **70** to the substrate **50** to form the dipole antenna **10**, as shown in FIG. 7E; and configuring (111) the dipole antenna **10** to operate in a continuous frequency band of operation upon outputting the omni-directional output beam **35**, as shown in FIG. 7F. In an example, the conductive sheet **70** may be between approximately 32-40  $\mu\text{m}$ . The method **100** may comprise shaping the conductive sheet **70** using a suitable photoetching process. The method **100** may comprise machining the conductive sheet **70** from a predetermined material. The predetermined material may comprise flexible graphite, in one example. The predetermined material may comprise expanded metal (e.g., sheet metal that has been cut and stretched in a particular mesh-like pattern), in another example.

The method **100** may comprise positioning an input power feed point **85** on the dipole antenna **10**, as shown in FIG. 9, with reference to FIGS. 1 through 8, and attaching a radio frequency connector **30** at the input power feed point **85** of the dipole antenna **10**. The method **100** may comprise configuring a thickness and material composition of the dipole antenna **10** such that that dipole antenna **10** is structurally conformable. For receive-only applications, the connector **30** may be a SubMiniature version A radio frequency (SMA RF) connector, for example, that can be

attached at the feed point **85** such that the center conductor is attached to one arm, and the ground is attached to the opposite arm. The connector **30** can be attached through conventional soldering techniques or with conductive epoxy. A balun component such as a RF balun (not shown) may be used for transmitting applications to prevent radiation from the shield of the feed cable (not shown); however, the balun itself may become the limiting factor for impedance bandwidth or transmit power, and as such other techniques such as feeding with a co-planar waveguide geometry may be utilized for implementation of the antenna **10** in transmit applications.

The antenna arms **20** can be manufactured from any type of conductive sheet **70** or fine mesh material, such as aluminum and flexible graphite, for example. The skin effect depth at the low end of the operating band is considered when determining material thickness, with the rule of thumb being to provide five skin depths. The skin depth for aluminum at 165 MHz is approximately 6.4 microns; therefore, aluminum antenna arms may have a thickness no less than approximately 32 microns, according to an example. Additionally, the use of less conductive materials may reduce the radiation efficiency of the antenna **10**.

FIG. 10, with reference to FIGS. 1 through 9, illustrates a dipole antenna **110** comprising a substrate **150**. A first set **90** of a plurality of partially elliptical arms **120a**, **120b** are adjacent to one another and positioned on the substrate **50**, wherein successive arms **120a**, **120b** in the first set **90** are arranged in a progressively smaller configuration such that a distance  $d_1$ ,  $d_2$  between vertices  $V_1$ ,  $V_2$  of each successive arm in the first set **90** is progressively shorter than a preceding arm in the first set **90**. A first set of a plurality of curvilinear gaps **1801** separates a portion of each arm from an adjacent arm (e.g., between arms **120a** and **120b**, for example).

A second set **95** of a plurality of partially elliptical arms **120c**, **120d** is adjacent to one another and positioned on the substrate **150**, wherein successive arms **120c**, **120d** in the second set **95** are arranged in a progressively smaller configuration such that a distance  $d_3$ ,  $d_4$  between vertices  $V_3$ ,  $V_4$  of each successive arm in the second set **95** is progressively shorter than a preceding arm in the second set **95**. A second set **95** of a plurality of curvilinear gaps **1802** separates a portion of each arm from an adjacent arm (e.g., between arms **120c** and **120d**, for example). In an example, there is a symmetrical arrangement of the first set **90** with respect to the second set **95** creating a dipole antenna configuration **155**, wherein the dipole configuration **155** operates in a continuous frequency band of operation.

The plurality of partially elliptical arms **120a-120d** are substantially crescent-shaped. Each set **90**, **95** of the plurality of partially elliptical arms **120a-120d** comprises a first crescent-shaped arm **120a** comprising a first inflection point (e.g., vertex  $V_1$ ) and a first convex edge **160a**; a second crescent-shaped arm **120b** comprising a second inflection point (e.g., vertex  $V_2$ ) and a second convex edge **160b**, wherein the second inflection point (e.g., vertex  $V_2$ ) is offset from the first inflection point (e.g., vertex  $V_1$ ) by a first distance  $D_1$ ; a third crescent-shaped arm **120c** comprising a third inflection point (e.g., vertex  $V_3$ ) and a third convex edge **160c**; and a fourth crescent-shaped arm **120d** comprising a fourth inflection point (e.g., vertex  $V_4$ ) and a fourth convex edge **160d**, wherein the fourth inflection point (e.g., vertex  $V_4$ ) is offset from the third inflection point (e.g., vertex  $V_3$ ) by a second distance  $D_2$  equal to the first distance  $D_1$ . The plurality of partially elliptical arms **120a**, **120b** further include, respectively, a first concave edge **161a** and

a second concave edge 161b oriented in the same direction. Likewise, the plurality of partially elliptical arms 120c, 120d further include, respectively, a third concave edge 161c and the fourth concave edge 161d oriented in the same direction.

The symmetrical arrangement created by the dipole antenna configuration 155 of the first set 90 with respect to the second set 95 is defined by a line of tangent T, which is parallel to the lines defined by distances d1 . . . d4 between the respective inflection points (e.g., vertices V1 . . . V4). Each of the first set 90 of partially elliptical arms 120a, 120b and the second set 95 of partially elliptical arms 120c, 120d comprises a conductive material having a thickness of five skin depths at 165 MHz. The substrate 150 comprises any of a flexible material and a dielectric material. The plurality of curvilinear gaps 1801 in the first set 90 are of different sizes with respect to one another, and wherein the plurality of curvilinear gaps 1802 in the second set 95 are of different sizes with respect to one another.

With respect to FIG. 11, with reference to FIGS. 1 through 10, the following equations describe some example ellipses that can be used to derive the four elliptical or crescent-shaped arms 2201 . . . 2204 for the dipole antenna 210:

Crescent arm 2201:

Base ellipse: (x1^2/a1^2)+(y1^2/b1^2)=1, where a and b are the semi-major and semi-minor axes.

Gap 2801: (x1-1.9)^2/a1^2+(y1^2/b1^2)=1

Crescent arm 2202:

Base ellipse: (x2^2/a2^2)+(y2^2/b2^2)=1, where a and b are the semi-major and semi-minor axes.

Gap 2802: (x2-3.4)^2/a2^2+(y2^2/b2^2)=1

Crescent arm 2203:

Base ellipse: (x3^2/a3^2)+(y3^2/b3^2)=1, where a and b are the semi-major and semi-minor axes.

Gap 2803: (x3-3.4)^2/a3^2+(y3^2/b3^2)=1

Crescent arm 2204:

Base ellipse: (x4^2/a4^2)+(y4^2/b4^2)=1, where a and b are the semi-major and semi-minor axes.

Gap 2804: (x4-3.3)^2/a4^2+(y4^2/b4^2)=1

The overall shapes of the arms 2201 . . . 2204 are established by positioning the inflection points (e.g., vertices v1 . . . v4) of the convex edge 2601-2604 of each arm 2201 . . . 2204, respectively, a specified distance h1 . . . h4 directly above the corresponding point on the largest crescent arm (e.g., arm 2201). This is done such that the concave sides 2611 . . . 2614 of the crescent arms 2201 . . . 2204, respectively, are oriented in the same direction. For example, the specific offset distances h1 . . . h4 for the respective crescent-shaped arms 2201 . . . 2204 may be as follows (in cm): h1=0, h2=1, h3=6.2, h4=7, in one example embodiment.

In an example, the embodiments herein reduce the surface area of a conventional VHF/UHF elliptical dipole by 40% without loss of impedance bandwidth or a significant degradation of radiation pattern while simultaneously maintaining compatibility with composites manufacturing tech-

niques. In an example, to achieve this 40% reduction in surface area, the overall foot print of the completed antenna 210 may have a height=64.5 cm and a width=48 cm. According to an example, the height dimension includes a 2 mm gap 2801 . . . 2803 between the arms 2201 . . . 2204 at the feed point 285, which is located at the inflection point (e.g., vertex V) of the convex edge 2601 on the largest crescent arm 2201 of each dipole arm 220a, 220b.

The foregoing description of the specific embodiments will so fully reveal the general nature of the embodiments herein that others can, by applying current knowledge, readily modify and/or adapt for various applications such specific embodiments without departing from the generic concept, and, therefore, such adaptations and modifications should and are intended to be comprehended within the meaning and range of equivalents of the disclosed embodiments. It is to be understood that the phraseology or terminology employed herein is for the purpose of description and not of limitation. Those skilled in the art will recognize that the embodiments herein can be practiced with modification within the spirit and scope of the appended claims.

What is claimed is:

1. An antenna comprising:

a crescent-shaped antenna body comprising a plurality of crescent-shaped arms having crescent-shaped notched ends; and

a connector positioned on a substantially non-jagged portion of the crescent-shaped antenna body to receive input energy,

wherein the antenna body operates in a continuous frequency band of operation.

2. The antenna of claim 1, wherein the antenna body transmits an omni-directional output beam.

3. The antenna of claim 1, wherein the antenna body is structurally conformable.

4. The antenna of claim 1, wherein the antenna body is configured to attach to flexible surfaces.

5. The antenna of claim 1, wherein the antenna body is configured to attach to non-planar surfaces.

6. The antenna of claim 1, wherein the continuous frequency band of operation comprises approximately 165 MHz to 1.35 GHz.

7. The antenna of claim 1, wherein the antenna body is configured to have an average voltage standing wave ratio of approximately 1.72:1 across the continuous frequency band of operation.

8. The antenna of claim 1, wherein the antenna body is comprised of a foam substrate and is configured to have an average voltage standing wave ratio of approximately 1.85:1 across the continuous frequency band of operation.

9. The antenna of claim 1, wherein the antenna body comprises a dipole configuration.

\* \* \* \* \*