

(12) **United States Patent**
Beaman et al.

(10) **Patent No.:** **US 10,661,899 B2**
(45) **Date of Patent:** ***May 26, 2020**

(54) **IN FLIGHT TRANSFER OF PACKAGES BETWEEN AERIAL DRONES**

(58) **Field of Classification Search**
CPC B64D 1/00; B64C 27/08; B64C 37/02; B64C 39/024

(71) Applicant: **International Business Machines Corporation**, Armonk, NY (US)

(Continued)

(72) Inventors: **Brian S. Beaman**, Apex, NC (US);
Eric V. Kline, Rochester, MN (US);
Sarbajit K. Rakshit, Kolkata (IN)

(56) **References Cited**

U.S. PATENT DOCUMENTS

4,381,092 A 4/1983 Barker
6,540,179 B2 4/2003 Henderson

(Continued)

(73) Assignee: **INTERNATIONAL BUSINESS MACHINES CORPORATION**, Armonk, NY (US)

OTHER PUBLICATIONS

(*) Notice: Subject to any disclaimer, the term of this patent is extended or adjusted under 35 U.S.C. 154(b) by 191 days.

Beaman, Brian S., et al., "In Flight Transfer of Packages Between Aerial Drones" U.S. Appl. No. 15/401,475, filed Jan. 9, 2017.

This patent is subject to a terminal disclaimer.

(Continued)

(21) Appl. No.: **15/823,832**

Primary Examiner — Thomas G Black

Assistant Examiner — Luat T Huynh

(22) Filed: **Nov. 28, 2017**

(74) *Attorney, Agent, or Firm* — Cantor Colburn LLP; Tihon Poltavets

(65) **Prior Publication Data**

US 2018/0086460 A1 Mar. 29, 2018

Related U.S. Application Data

(63) Continuation of application No. 15/401,475, filed on Jan. 9, 2017, now Pat. No. 9,889,933, which is a (Continued)

(57) **ABSTRACT**

Aspects include a system for transferring a payload between drones. The system includes a first aerial drone having a first transfer member and a first controller. The first controller including a processor configured to change a first altitude and first orientation of the first aerial drone. A second aerial drone is provided having a second transfer member and a second controller, the second transfer member having a cone member on one end, the second transfer member being configured to receive the payload. The second controller including a processor configured to change a second altitude and a second orientation of the second aerial drone. The controllers cooperate to dispose the first transfer member within the cone member and transfer the payload from the first aerial drone to the second aerial drone.

(51) **Int. Cl.**
B64D 1/00 (2006.01)
B64C 39/02 (2006.01)

(Continued)

(52) **U.S. Cl.**
CPC **B64D 1/00** (2013.01); **B64C 27/08** (2013.01); **B64C 37/02** (2013.01); **B64C 39/024** (2013.01);

(Continued)

20 Claims, 22 Drawing Sheets

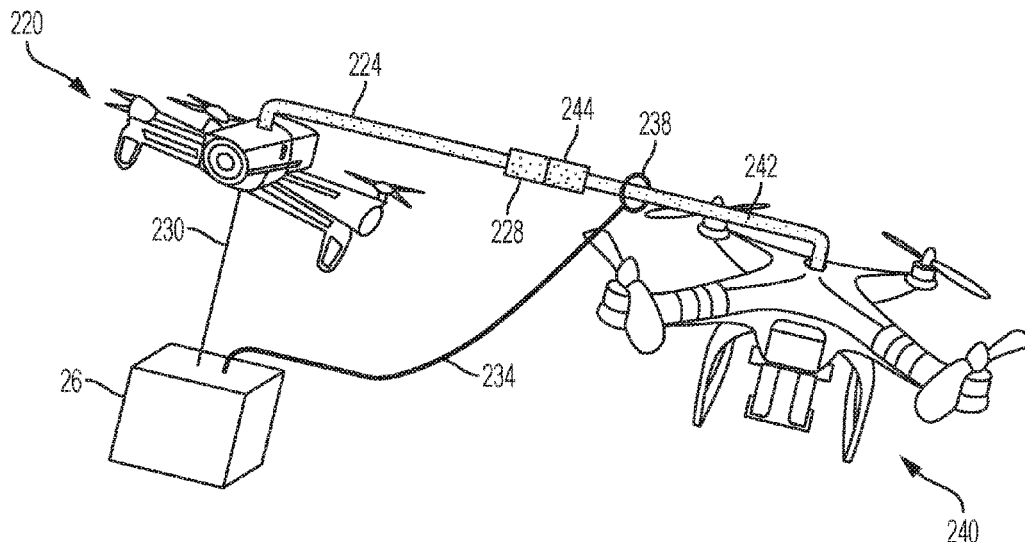

Related U.S. Application Data

continuation of application No. 14/987,155, filed on Jan. 4, 2016, now Pat. No. 9,561,852.

- (51) **Int. Cl.**
B64C 37/02 (2006.01)
B64C 27/08 (2006.01)
- (52) **U.S. Cl.**
 CPC .. *B64C 2201/024* (2013.01); *B64C 2201/027* (2013.01); *B64C 2201/108* (2013.01); *B64C 2201/128* (2013.01); *B64C 2201/141* (2013.01); *B64C 2201/143* (2013.01); *B64C 2201/165* (2013.01)
- (58) **Field of Classification Search**
 USPC 701/11
 See application file for complete search history.

(56) **References Cited**

U.S. PATENT DOCUMENTS

6,869,042	B2	3/2005	Harrison	
7,793,888	B2	9/2010	Padan	
8,056,860	B2	11/2011	Small et al.	
8,226,025	B2	7/2012	Gomez et al.	
8,989,924	B2	3/2015	Seydoux et al.	
9,561,852	B1 *	2/2017	Beaman	B64D 1/00
9,630,712	B1 *	4/2017	Carmack	B64C 39/024
2012/0251280	A1	10/2012	Jaurand et al.	
2015/0120094	A1	4/2015	Kimchi et al.	
2015/0323932	A1	11/2015	Paduano et al.	
2016/0070264	A1	3/2016	Hu et al.	
2016/0376031	A1 *	12/2016	Michalski	B64C 39/024 701/15
2017/0334561	A1 *	11/2017	Sopper	B64D 1/22

OTHER PUBLICATIONS

Beaman, Brian S., et al., "In Flight Transfer of Packages Between Aerial Drones" U.S. Appl. No. 15/823,832, filed Nov. 28, 2017. List of IBM Patents or Patent Applications Treated as Related; Date Filed: Nov. 28, 2017, pp. 1-2.

Chappell, Bill "Robot Swarm: A Flock of Drones That Fly Autonomously", NPR.org; retrieved at: <https://www.npr.org/sections/thetwo-way/2014/02/26/283090909/robot-swarm-a-flock-of-drones-that-fly-autonomously>; dated Feb. 26, 2014; 10 pgs.

Ciarletta, et al. "Simulation and Platform Tools to develop safe flock of UAVs : a CPS Application-Driven Research", 2014 IEEE; 2014 Int'l Conference on Unmanned Aircraft Systems; 2014 ICUAS, May 27-30, 2014; 8 pgs.

Demmitt, Jacob "Drones set to deliver a package in the U.S. for the first time next month, but Amazon won't be involved", Puget Sound Business Journal: <http://www.bizjournals.com/seattle/blog/techflash/2015/06/drones-set-to-deliver-a-package-in-the-u-s-for-the.html>; Jun. 23, 2015; 2 pgs.

Flitetest "Mid-Air Package Exchange—Viewer Response" dated Apr. 23, 2013; retrieved at: <https://www.flitetest.com/articles/360-degree-fpv-mount-viewer-response>; 18 pgs.

Maza, I. et al. "Multi-UAV cooperation and control for load transportation and deployment", Journal of Intelligent and Robotic Systems manuscript No. Unassigned; First online: Aug. 13, 2009; located at: <http://dx.doi.org/10.1007/s10846-009-9352-8>; 28 pgs.

Schwartz, Eric Hal "The First Delivery by Drone in the U.S. Will be Medicine from Virginia Tech", DCinno; retrieved from <https://www.americaninno.com/dc/virginia-tech-will-make-first-drone-commercial-delivery/>; dated Jun. 24, 2015; 2 pgs.

Wilson, Dan "Autonomous Airborne Docking for Refueling or Recharging", DIY Drones the Leading Community for Personal UAVs; retrieved from: <https://diydrones.com/profiles/blog/show?id=705844%3ABlogPost%3A1971342&commentId=705844%3A>; dated Apr. 18, 2015; 6 pgs.

Wilson, Daniel B. "Guidance and Navigation for UAV Airborne Docking" roboticsproceedings.org, RSS 11, P17, 2006.

Wilson, Daniel, PhD "Sky-high refuelling for UAVs"; The University of Sydney; located at: <http://sydney.edu.au/news/84.html?newsstoryid=14848>; dated Apr. 23, 2015; 1 pg.

Yong, Ed "Autonomous drones flock like birds" Nature.com; retrieved at: <http://www.nature.com/news/autonomous-drones-flock-like-birds-1.14776>; dated Feb. 26, 2014; 3 pgs.

YouTube "Load transportation using multiple UAVs" published on Dec 21, 2007; retrieved from <https://www.youtube.com/watch?v=t16DYWNe9ac>; Technische Universitat Berlin; 2 pgs.

* cited by examiner

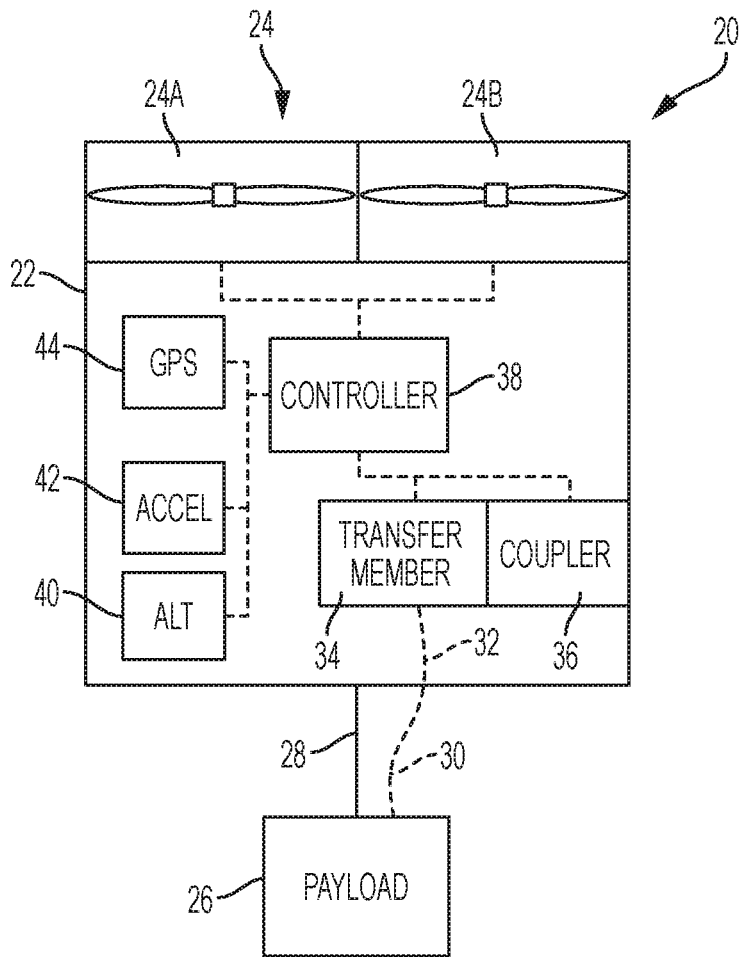

FIG. 1

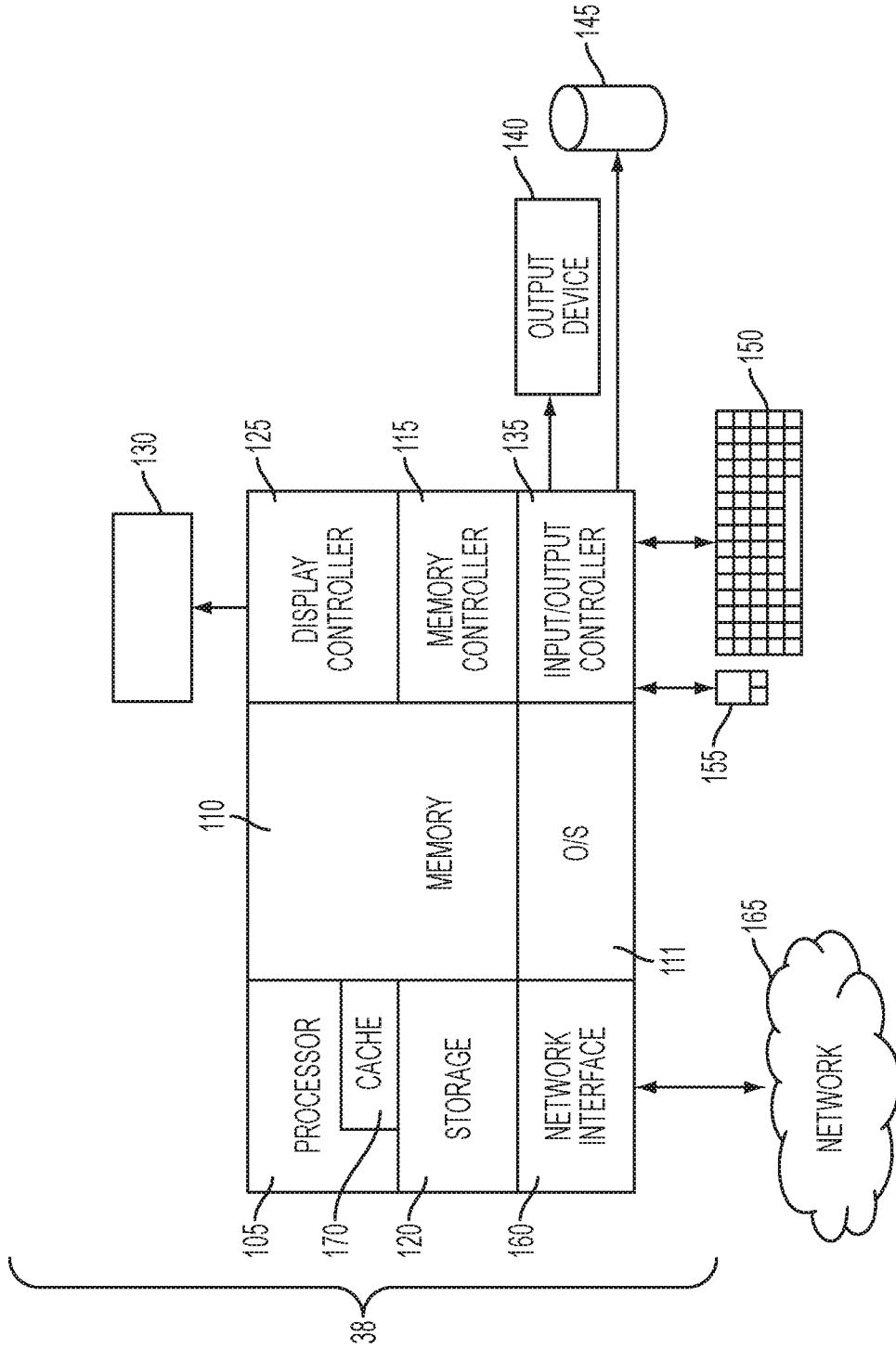

FIG. 2

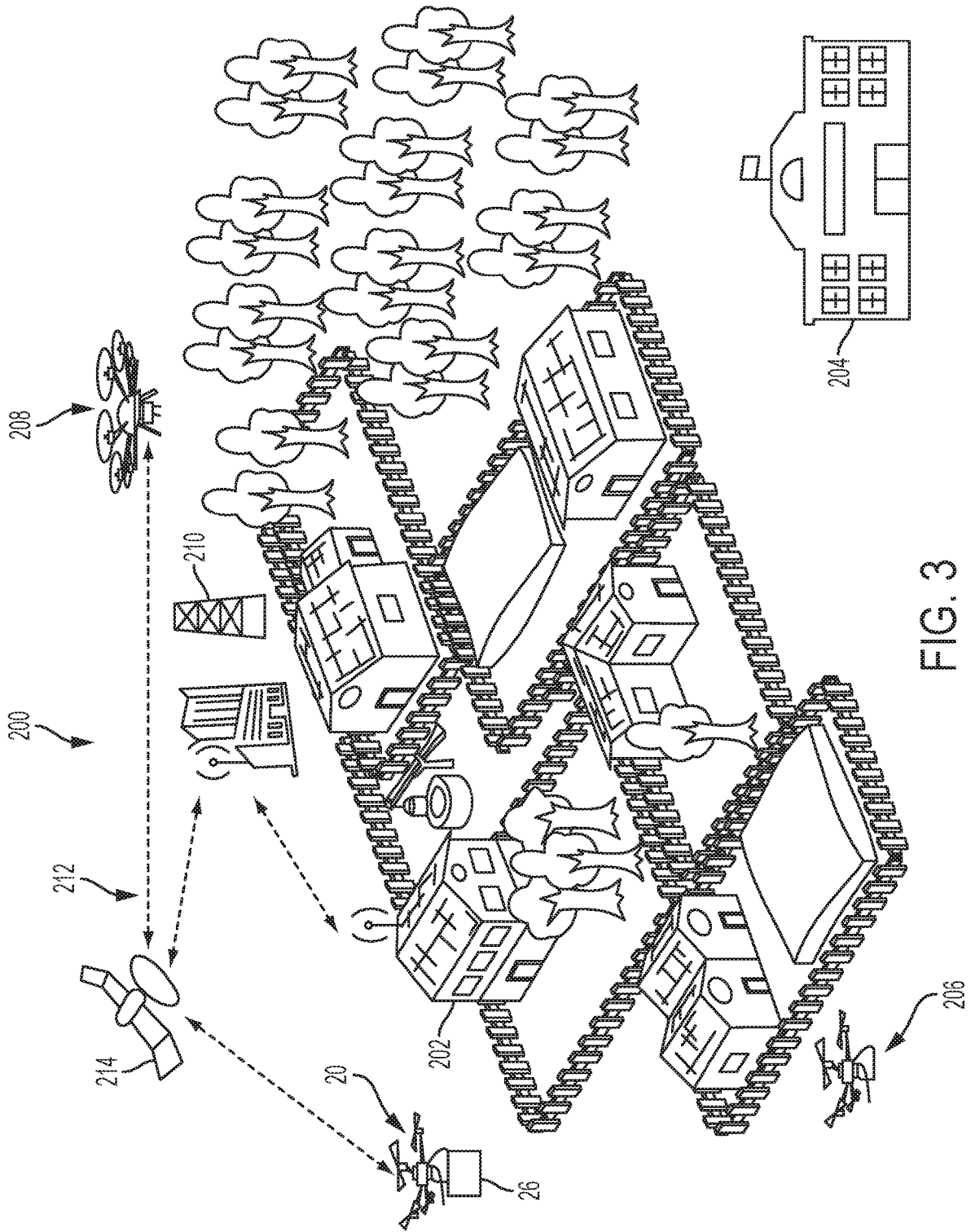

FIG. 3

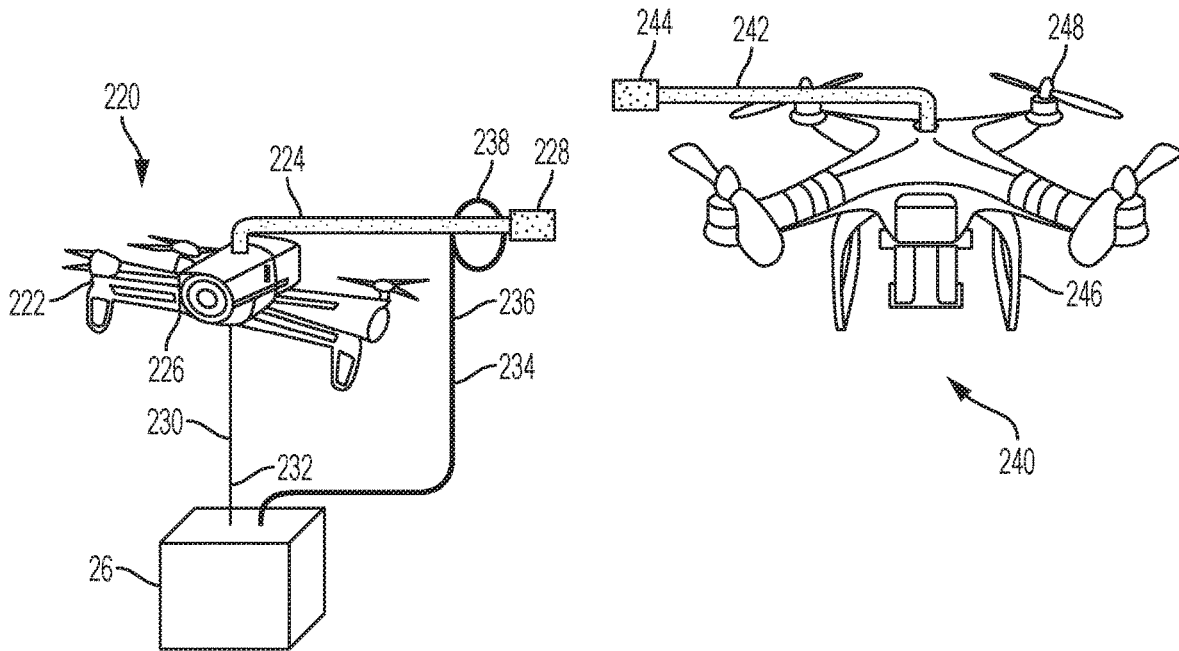

FIG. 4

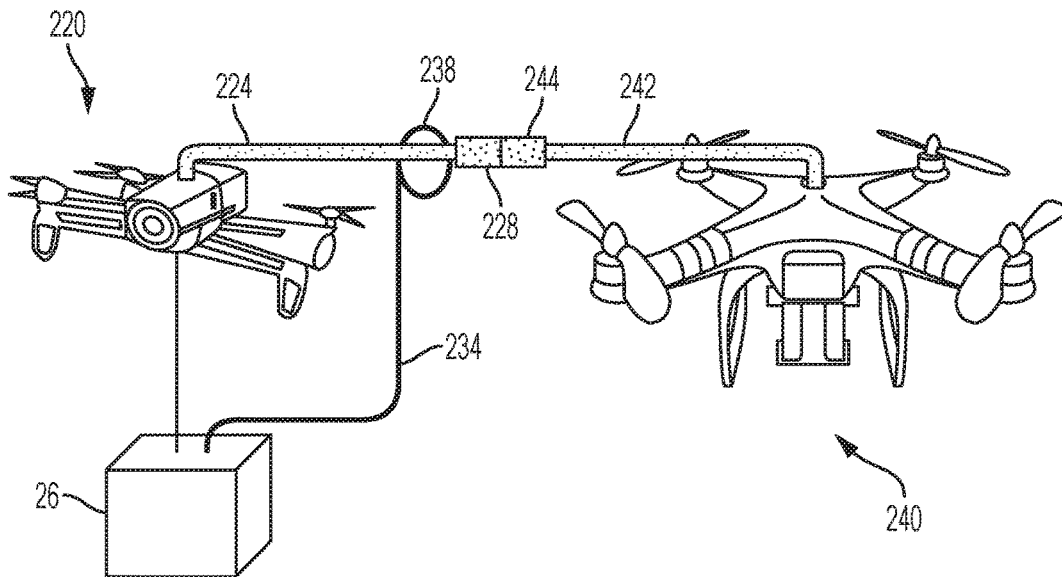

FIG. 5

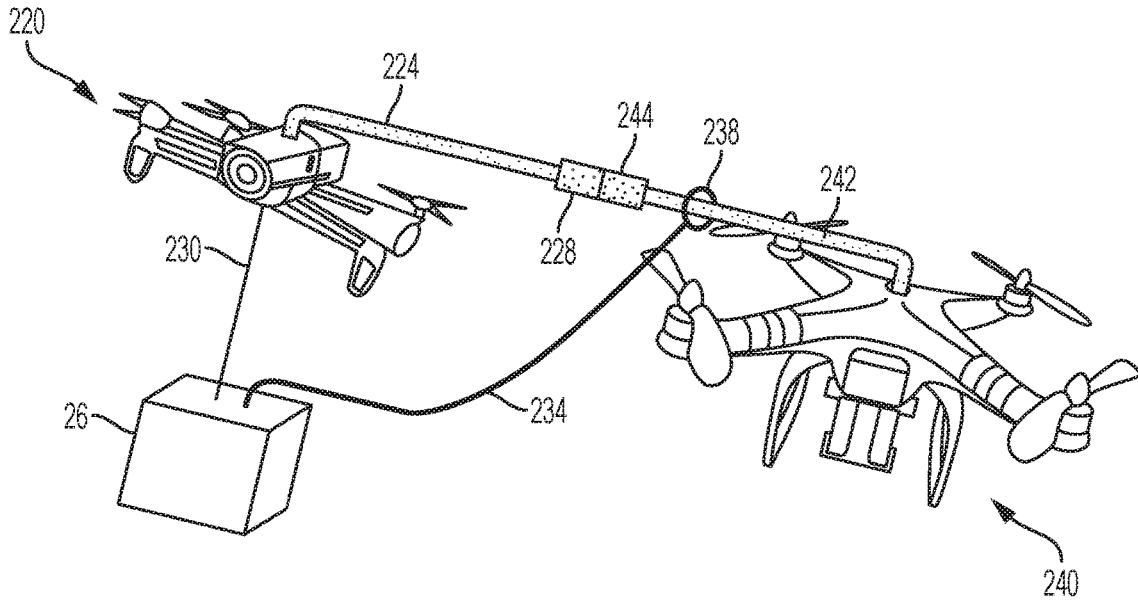

FIG. 6

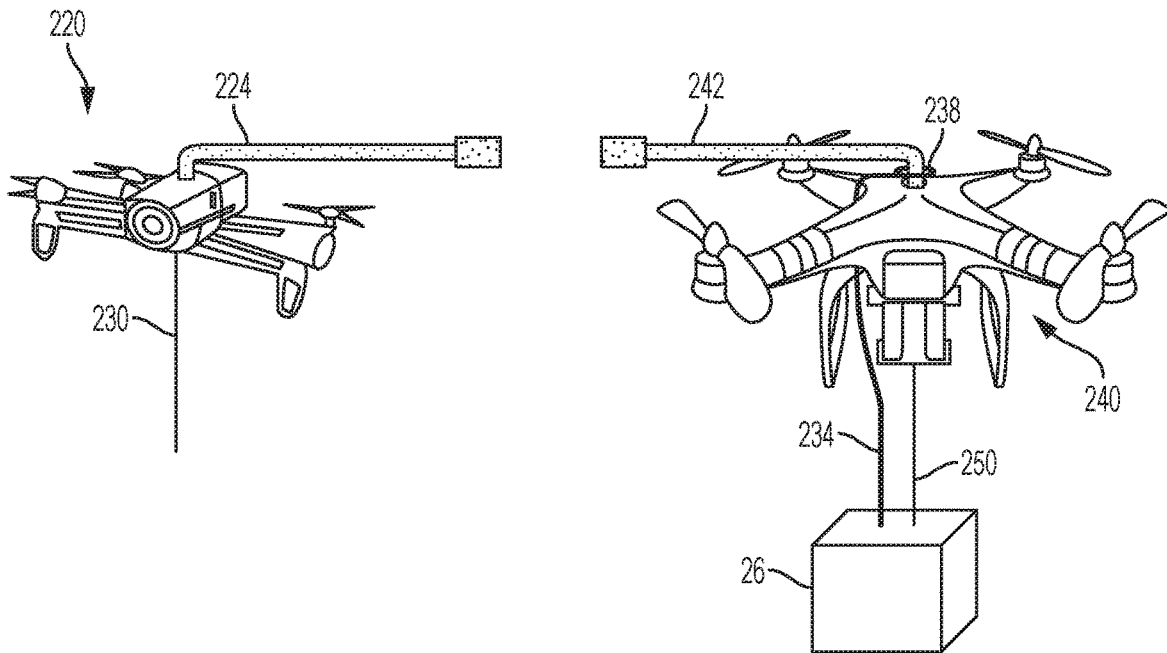

FIG. 7

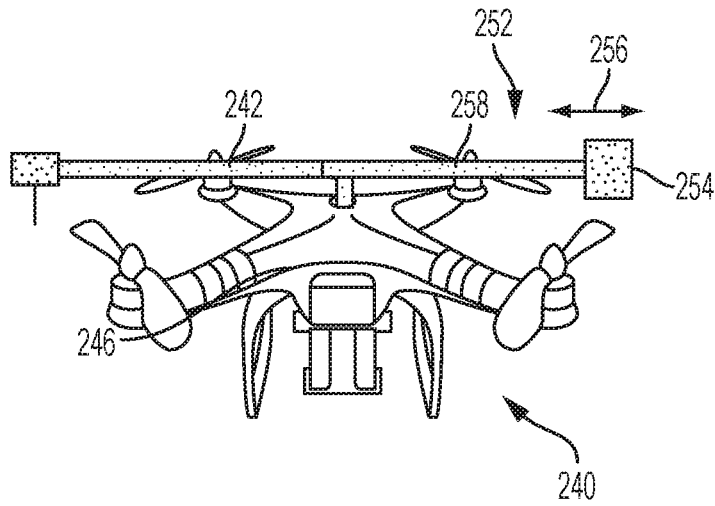

FIG. 8

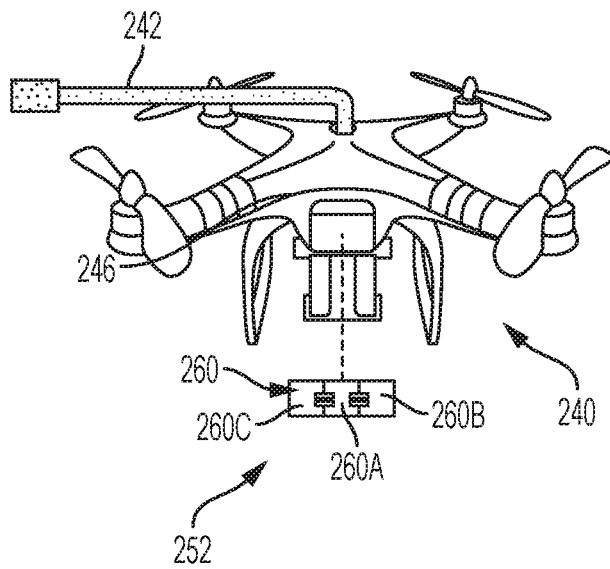

FIG. 9

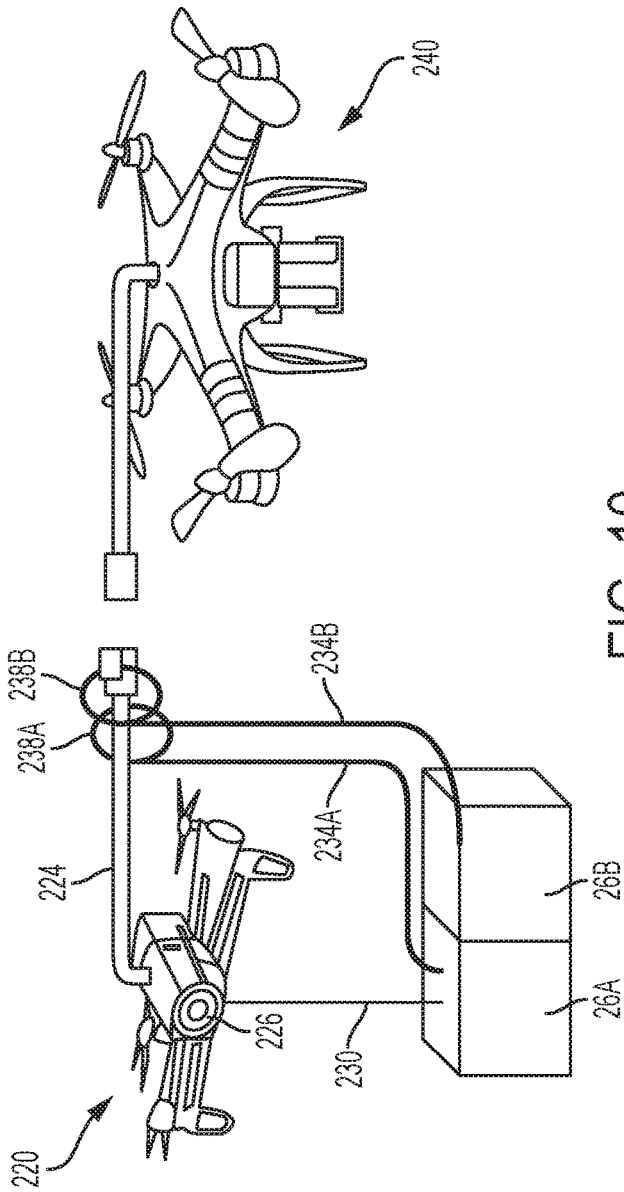

FIG. 10

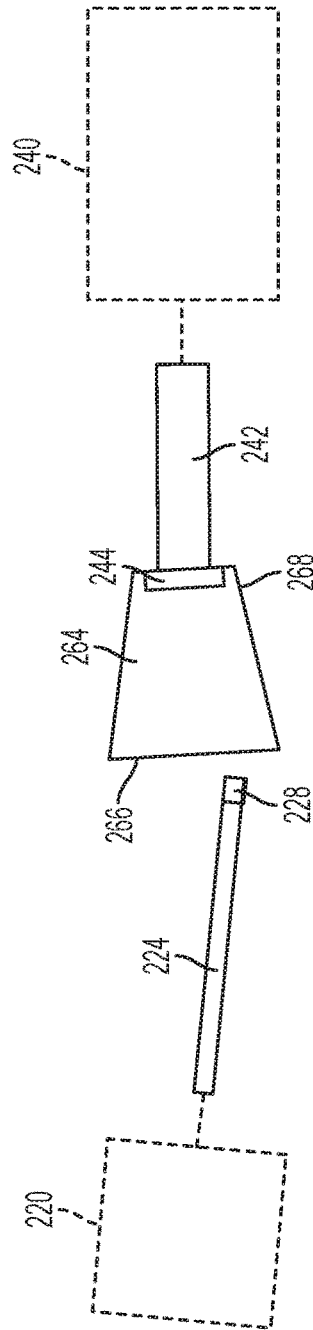

FIG. 11

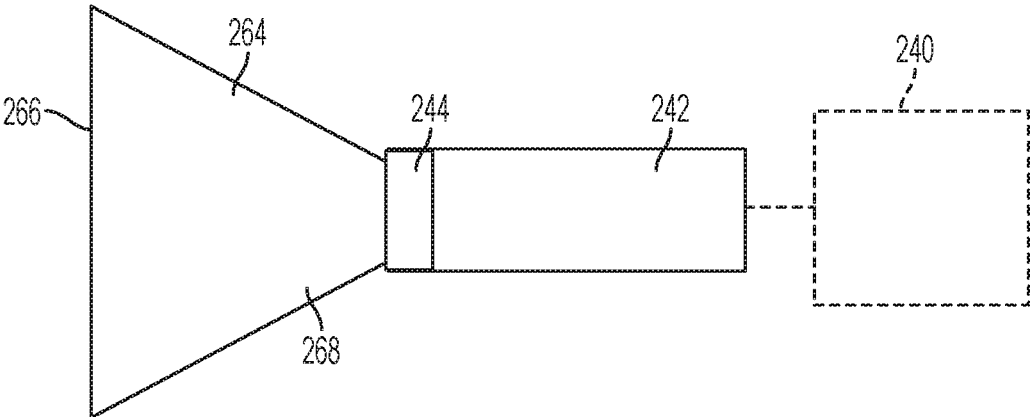

FIG. 12A

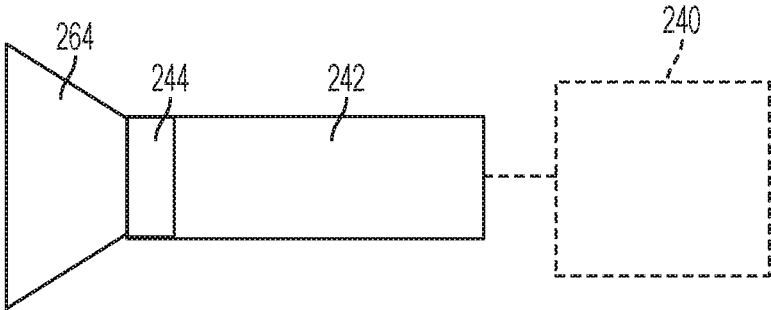

FIG. 12B

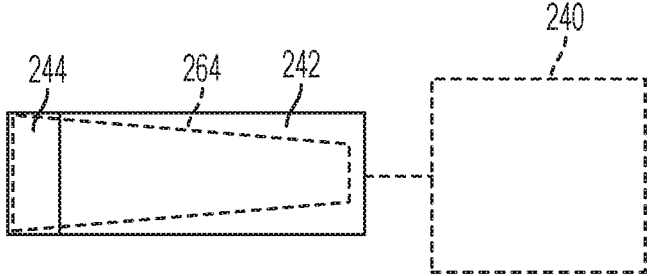

FIG. 12C

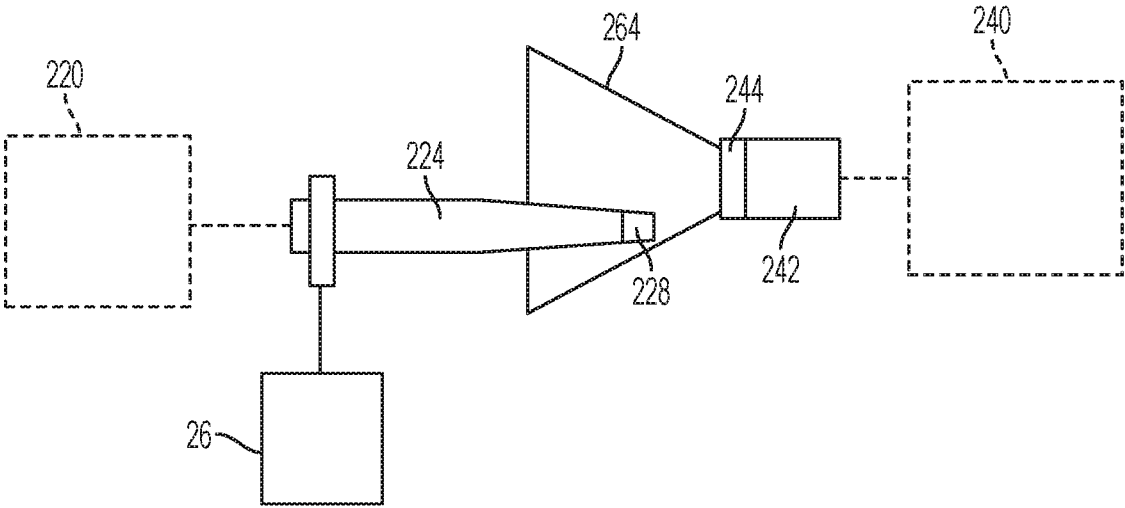

FIG. 13A

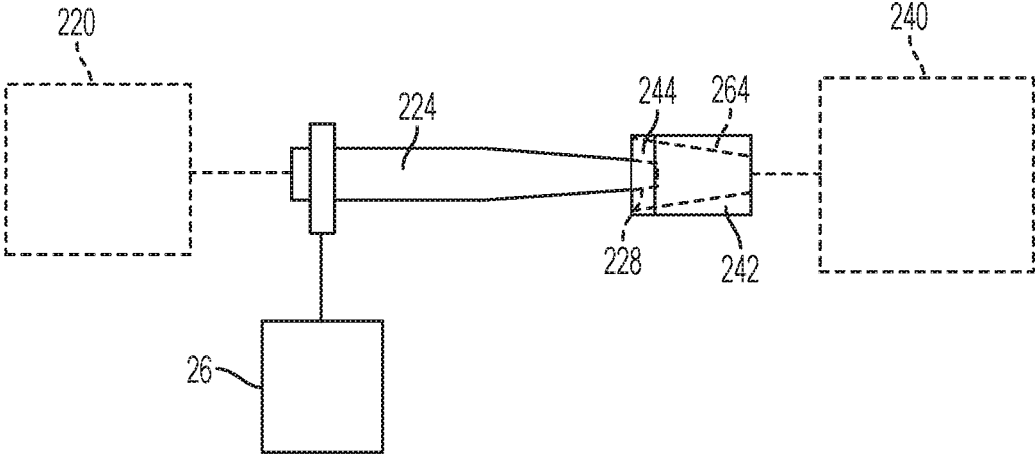

FIG. 13B

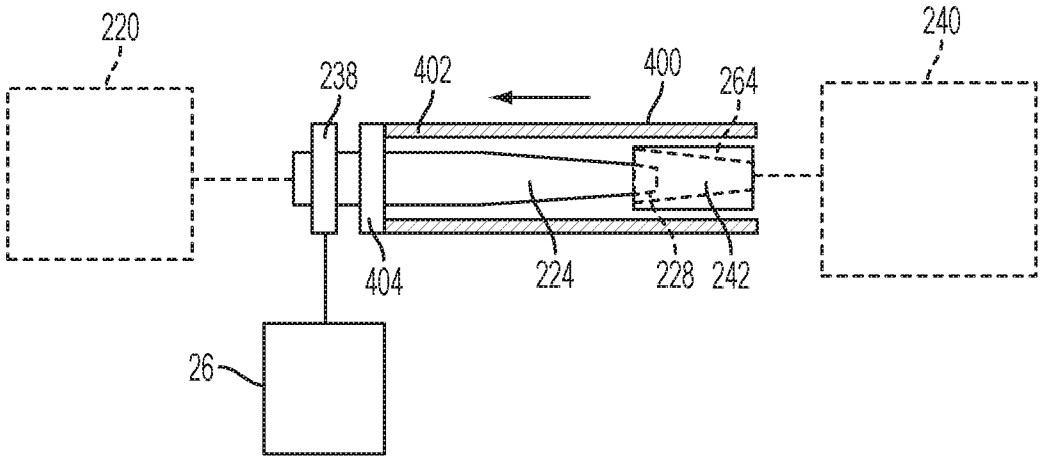

FIG. 14A

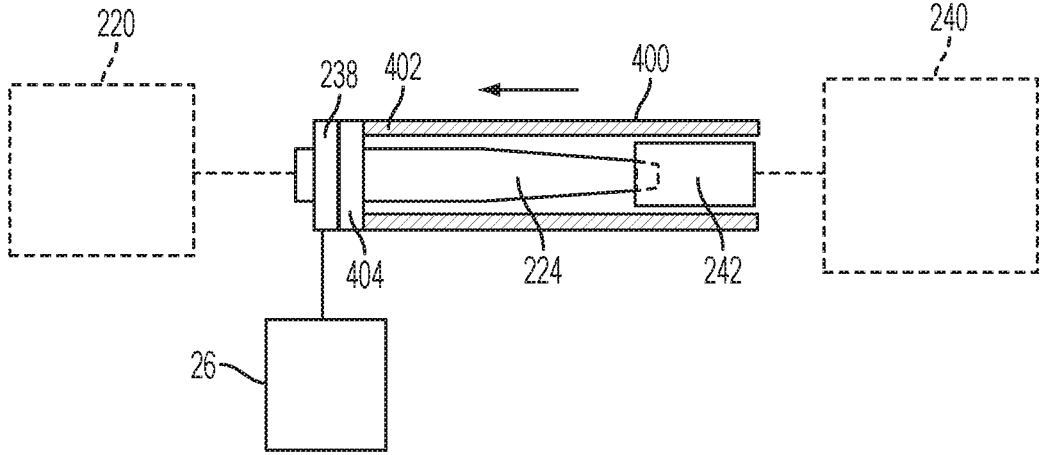

FIG. 14B

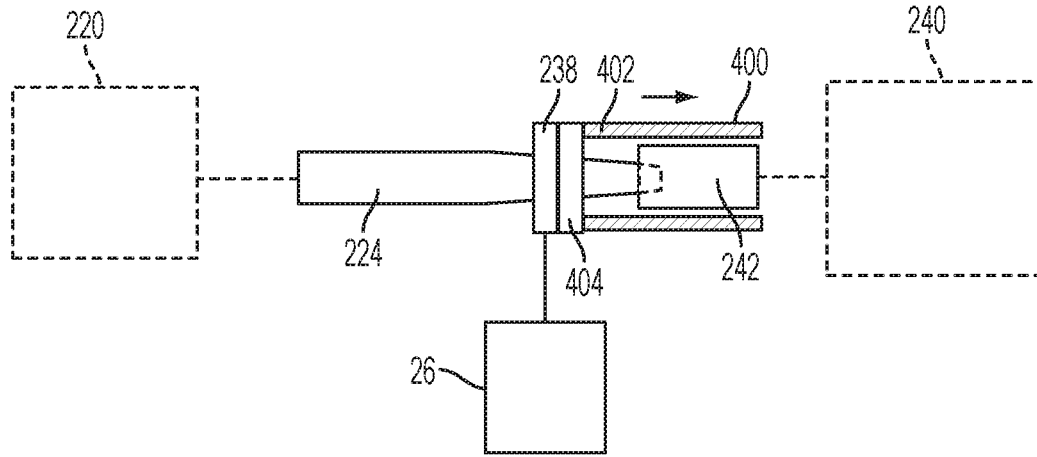

FIG. 14C

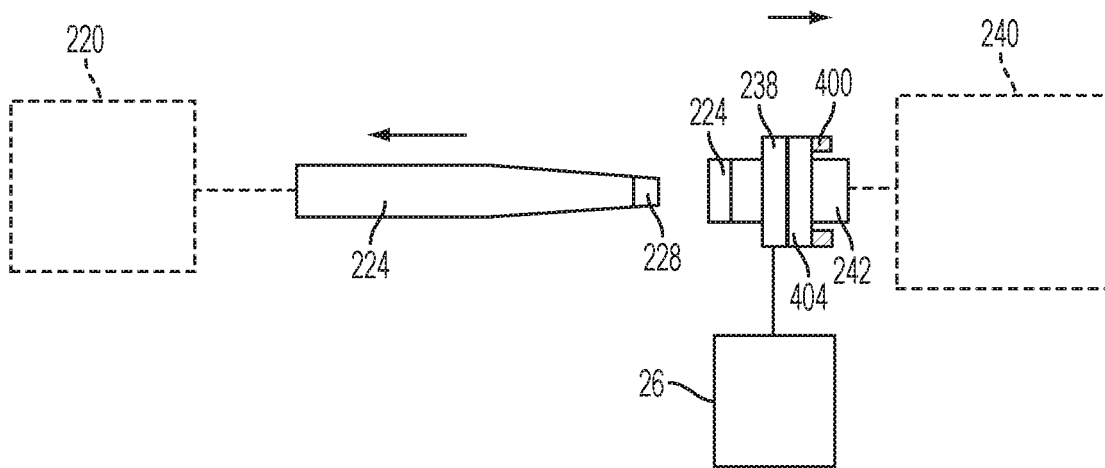

FIG. 14D

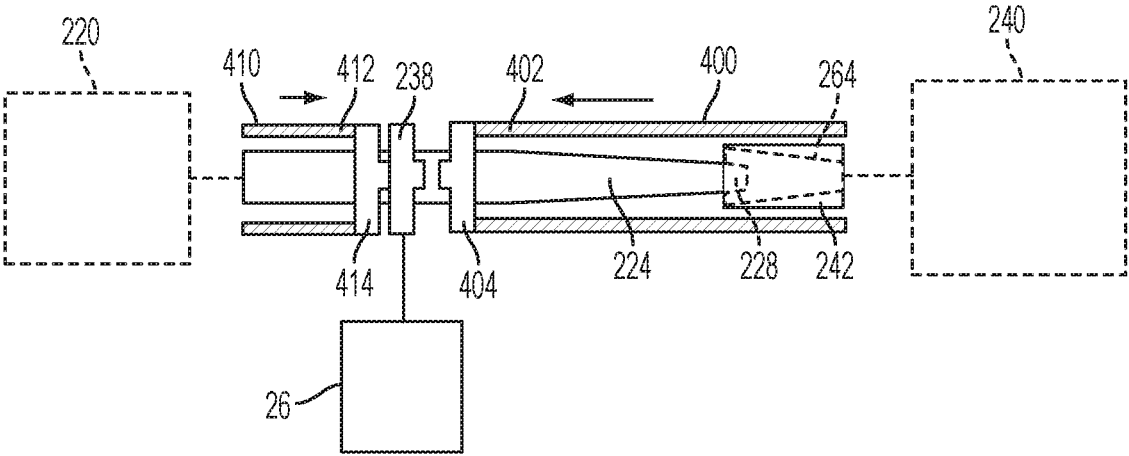

FIG. 15A

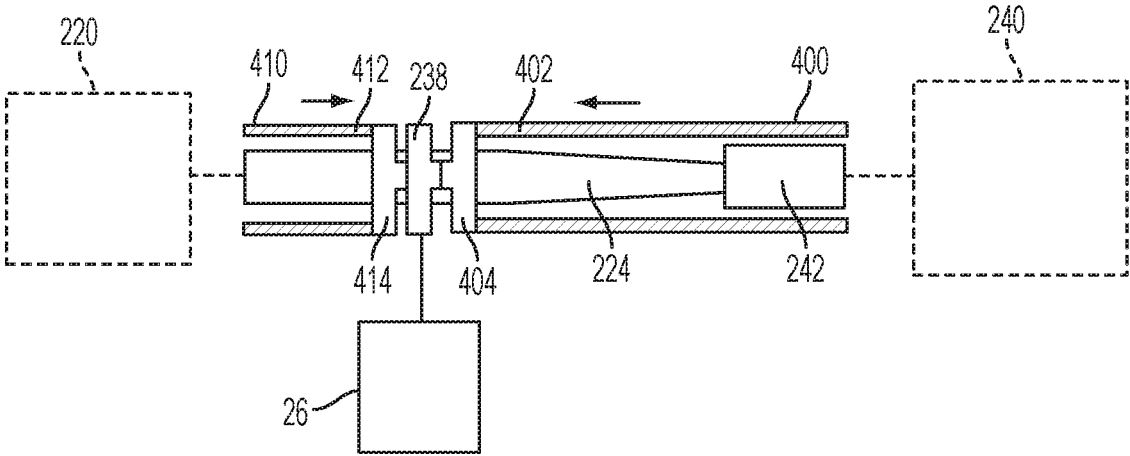

FIG. 15B

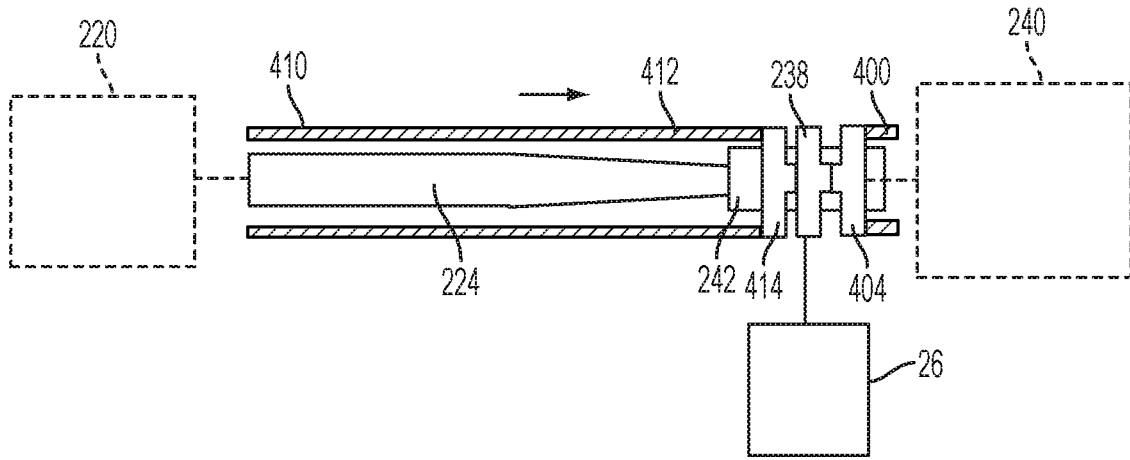

FIG. 15C

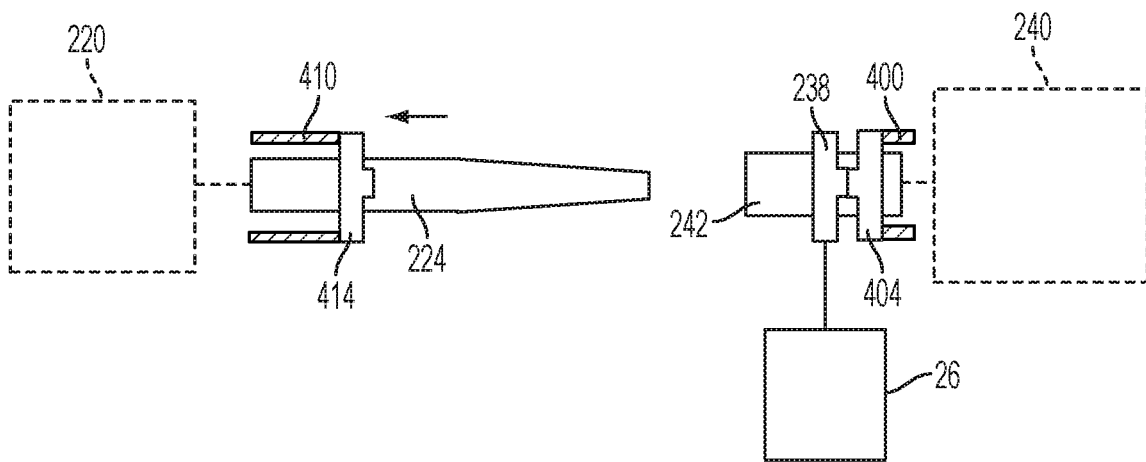

FIG. 15D

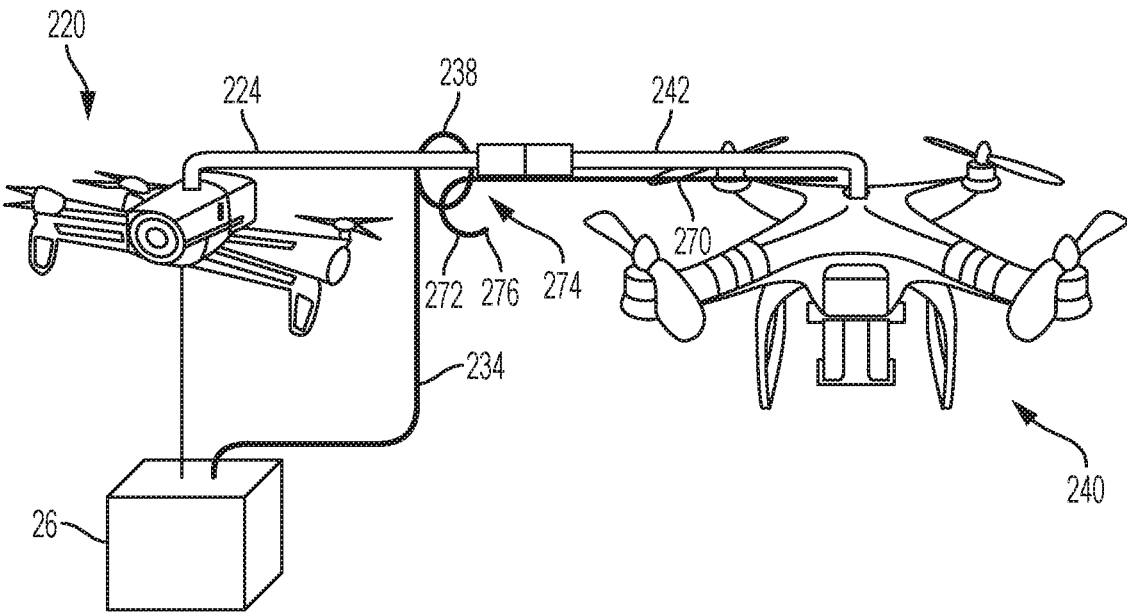

FIG. 16

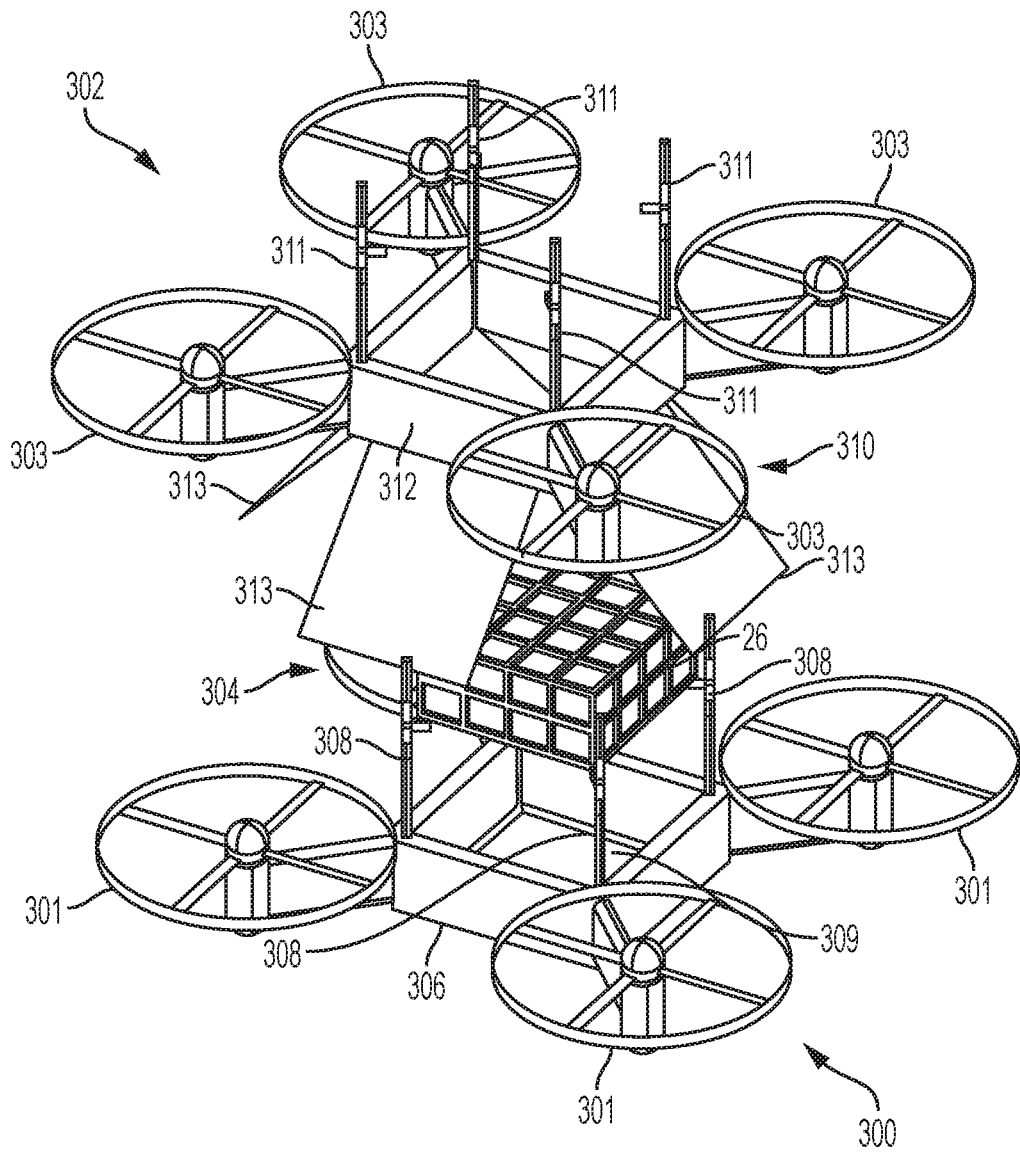

FIG. 17

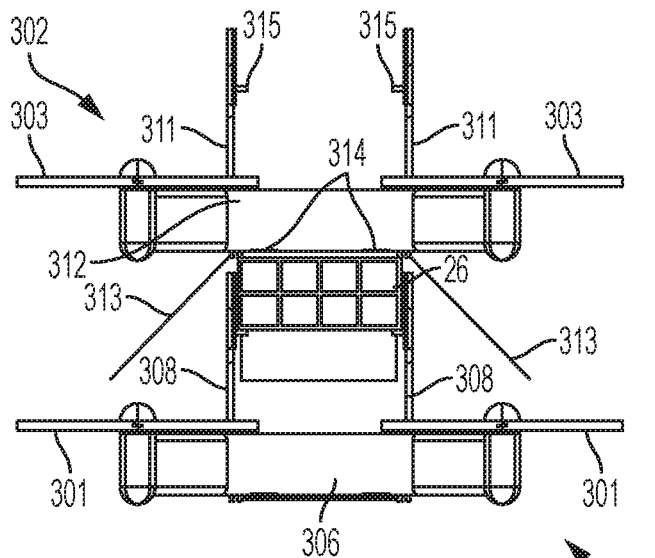

FIG. 18C

300

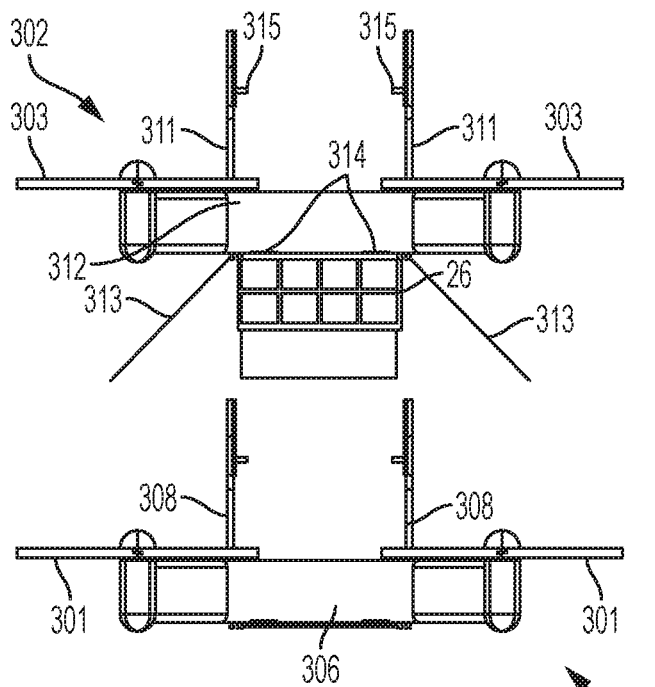

FIG. 18D

300

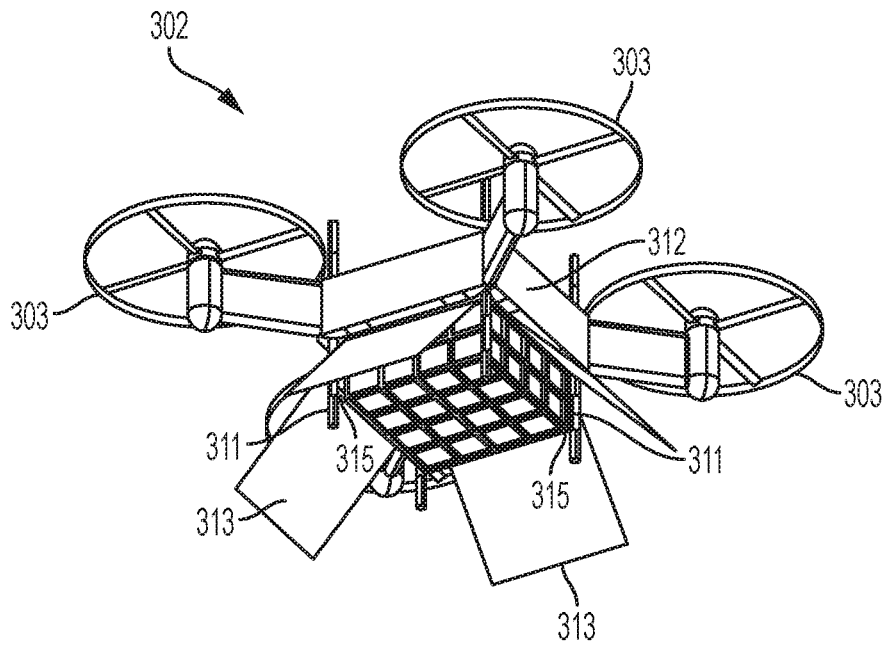

FIG. 19A

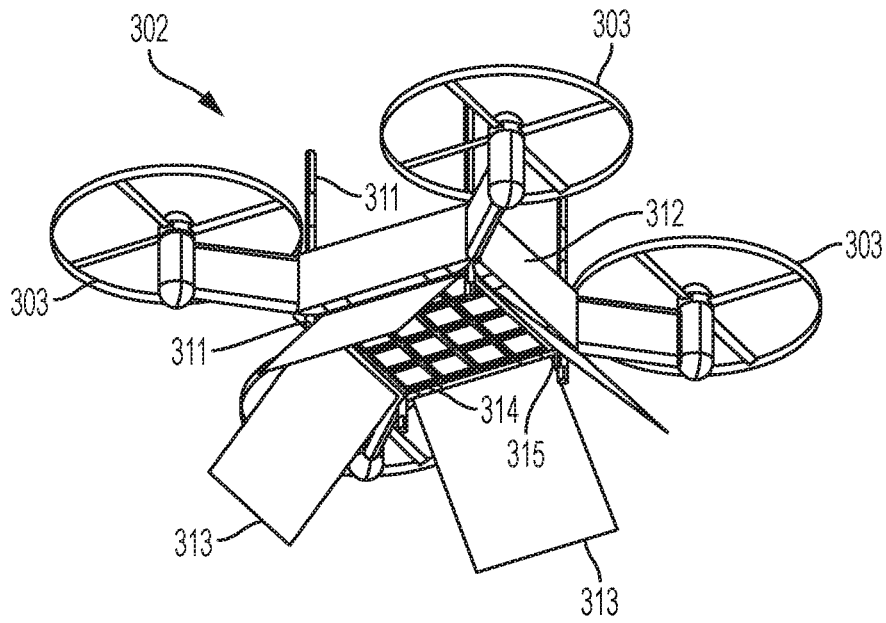

FIG. 19B

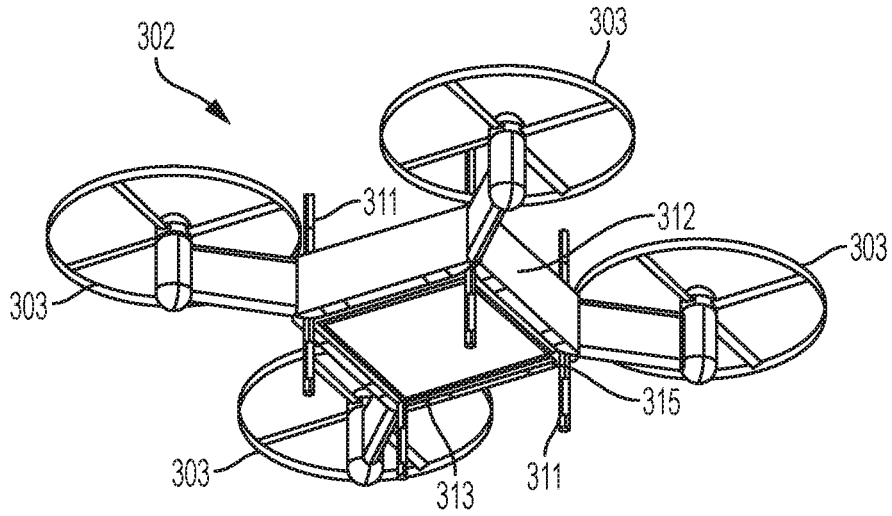

FIG. 19C

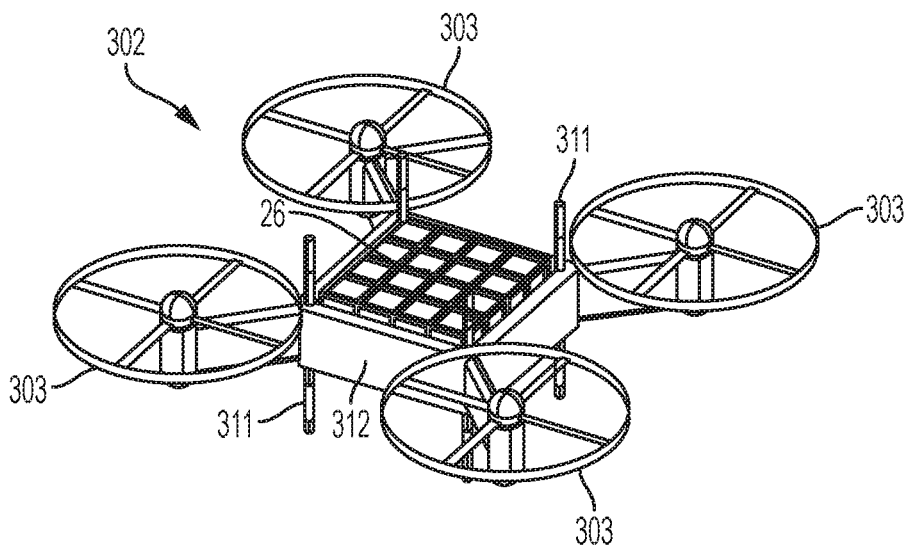

FIG. 19D

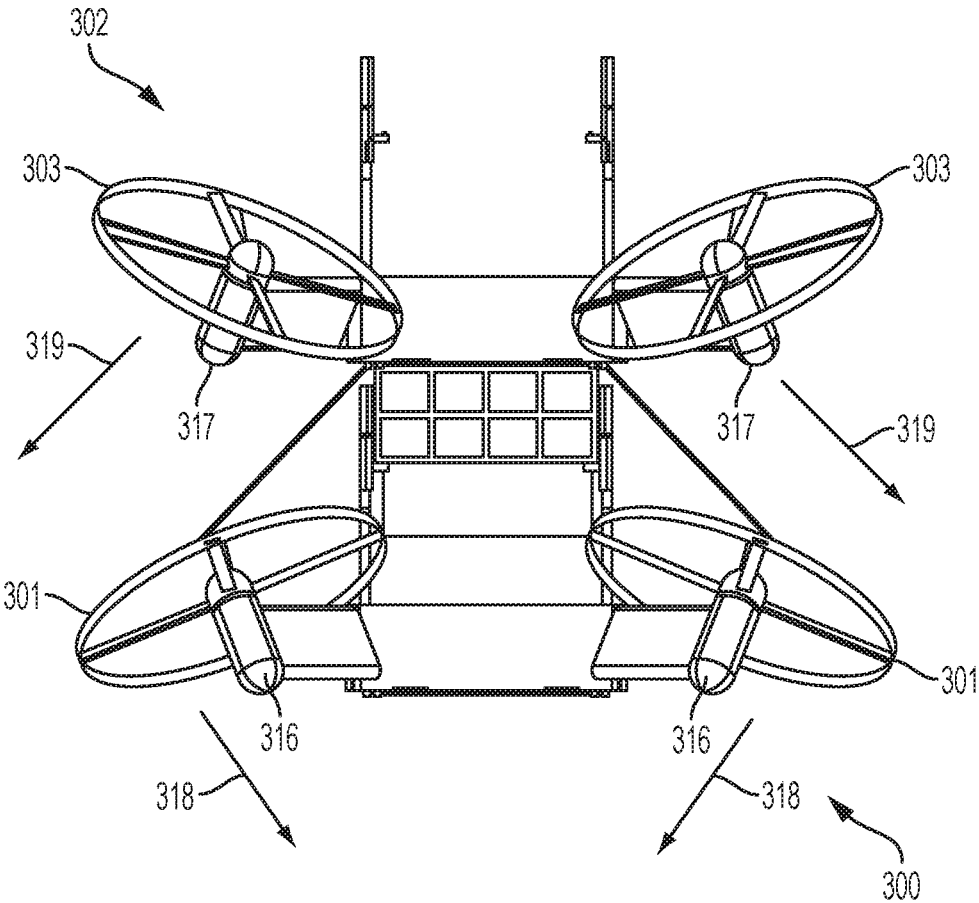

FIG. 20

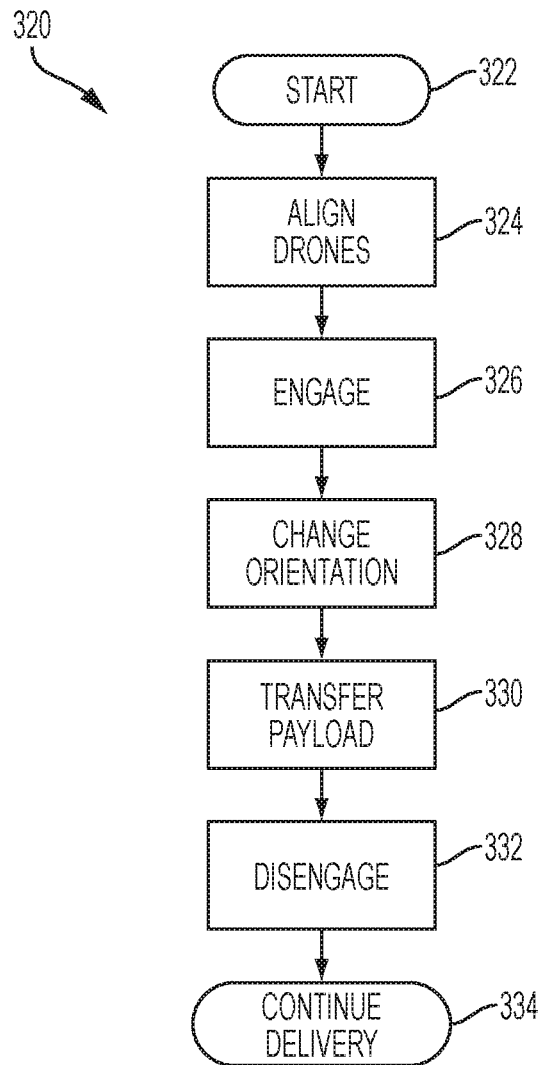

FIG. 21

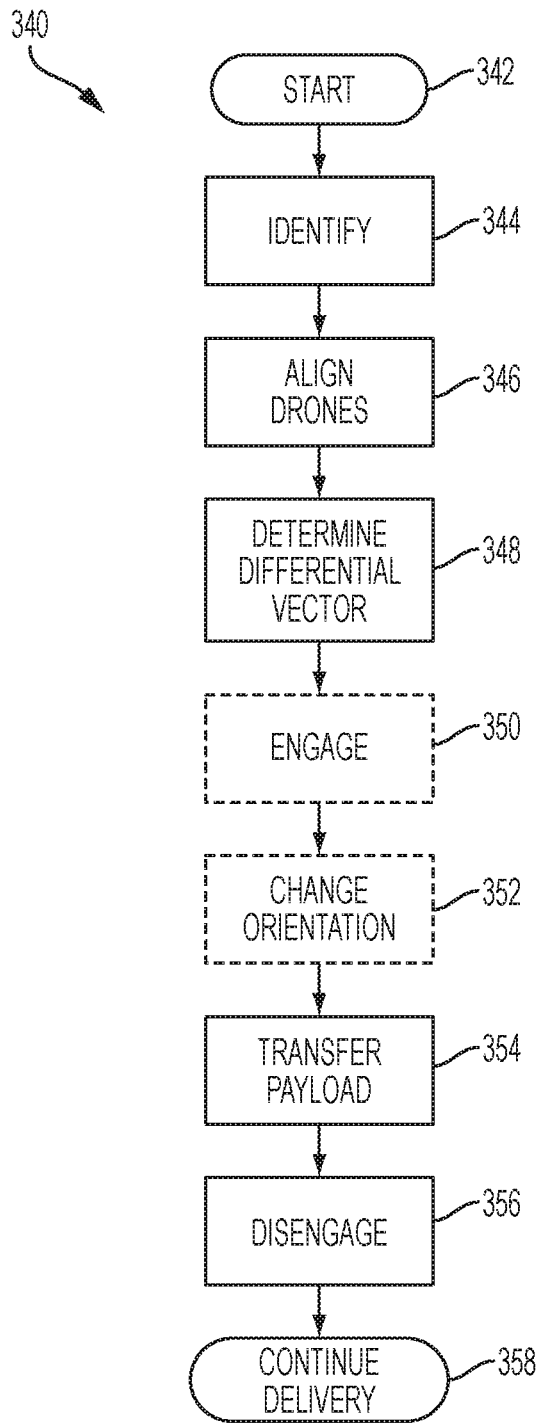

FIG. 22

1

IN FLIGHT TRANSFER OF PACKAGES BETWEEN AERIAL DRONES

CROSS-REFERENCE TO RELATED APPLICATIONS

The present application is a continuation application of U.S. patent application Ser. No. 15/401,475 filed on Jan. 9, 2017, which is a continuation application of U.S. patent application Ser. No. 14/987,155 filed on Jan. 4, 2016.

BACKGROUND

The present invention relates generally to a system and method for transferring packages and, more specifically, to a system and method for transferring packages between autonomous drones or unmanned aerial vehicles during flight.

Autonomous drones, also referred to as unmanned aerial vehicles (UAVs) and remotely piloted aircraft (RPA), are expected to be ruled eligible for use by private and corporate entities subject to pending to regulations implemented by various aviation authorities such as, for example, the Federal Aviation Administration (FAA). Proposed uses for drones include, but are not limited to, city ordinance enforcement, other government functions, package delivery, and image capturing. Therefore, it is envisioned that users could purchase drones to achieve a certain set of needs or tasks such as delivering a payload from a warehouse to a customer.

SUMMARY

Embodiments include a system for transferring a payload from an originating drone to a receiving drone. The system includes a first aerial drone having a first transfer member and a first controller, the first transfer member having a coupling device on one end, the first transfer member being configured to carry a payload. The first controller including a processor configured to change a first altitude and first orientation of the first aerial drone. The system also includes a second aerial drone having a second transfer member and a second controller, the second transfer member having a cone member on one end. The second transfer member is configured to receive the payload. The second controller including a processor configured to change a second altitude and a second orientation of the second aerial drone. Wherein the first controller and the second controller cooperate to change at least one of the first orientation and the second orientation to dispose the coupling device within the cone member and operably engage the first transfer member and second transfer member for transferring the payload from the first transfer member to the second transfer member while the first aerial drone and second drone are in-flight.

Further embodiments include an aerial drone. The aerial drone having a fuselage and a plurality of thrust producing devices coupled to the fuselage. A transfer member is coupled to the fuselage, the transfer member configured to move a payload to a second aerial drone. A controller is operably coupled to the plurality of thrust producing devices, the controller including a processor that is responsive to executable computer instructions to adjust the plurality of thrust producing devices to change an orientation of the transfer member to move the payload to the second aerial drone.

Still further embodiments include a method of in-flight transferring of a payload between aerial drones. The method includes providing a first aerial drone having a first transfer

2

member. A second aerial drone is provided having a second transfer member. An orientation is changed for at least one of the first aerial drone and the second aerial drone to position the first transfer member adjacent the second transfer member. The payload is moved from the first aerial drone to the second aerial drone.

Additional features are realized through the techniques of the present invention. Other embodiments and aspects of the invention are described in detail herein and are considered a part of the claimed invention. For a better understanding of the invention with the features, refer to the description and to the drawings.

BRIEF DESCRIPTION OF THE DRAWINGS

The subject matter which is regarded as the invention is particularly pointed out and distinctly claimed in the claims at the conclusion of the specification. The forgoing and other features of embodiments of the invention are apparent from the following detailed description taken in conjunction with the accompanying drawings in which:

FIG. 1 depicts a block diagram of an autonomous drone in accordance with an embodiment of this disclosure;

FIG. 2 depicts a block diagram of a controller for an autonomous drone in accordance with an embodiment of this disclosure;

FIG. 3 depicts a perspective view of a package delivery system using an autonomous drone in accordance with an embodiment of this disclosure;

FIG. 4, FIG. 5, FIG. 6, and FIG. 7 depict an in-flight payload transfer sequence between a pair of autonomous drones in accordance with an embodiment of this disclosure;

FIG. 8 depicts an autonomous drone having a dynamic counterbalancing system in accordance with an embodiment of this disclosure;

FIG. 9 depicts an autonomous drone having another dynamic counterbalancing system in accordance with an embodiment of this disclosure;

FIG. 10 depicts an in-flight package transfer of a payload between a pair of autonomous drones in accordance with an embodiment of this disclosure;

FIG. 11 depicts a transfer member coupling arrangement for use with a pair of autonomous drones in accordance with an embodiment of the invention;

FIG. 12A, FIG. 12B and FIG. 12C depict a transfer member coupling arrangement for use with a pair of autonomous drones in accordance with an embodiment of the invention;

FIG. 13A and FIG. 13B depict a transfer member coupling arrangement for use with a pair of autonomous drones in accordance with an embodiment of the invention;

FIG. 14A, FIG. 14B, FIG. 14C and FIG. 14D depict a transfer member coupling arrangement for use with a pair of autonomous drones in accordance with an embodiment of the invention;

FIG. 15A, FIG. 15B, FIG. 15C and FIG. 15D depict a transfer member coupling arrangement for use with a pair of autonomous drones in accordance with an embodiment of the invention;

FIG. 16 depicts another transfer member coupling arrangement for use with a pair of autonomous drones in accordance with an embodiment of the invention;

FIG. 17 depicts an in-flight transfer of a payload between a pair of autonomous drones in accordance with an embodiment of this disclosure;

FIG. 18A, FIG. 18B, FIG. 18C and FIG. 18D depict an in-flight sequence of the transfer of a payload between the pair of autonomous drones of FIG. 17;

FIG. 19A, FIG. 19B, FIG. 19C and FIG. 19D depict an in-flight sequence for securing the payload transferred between the pair of autonomous drones of FIG. 17;

FIG. 20 depicts a pair of autonomous drones having tilting rotors in accordance with some embodiments of this disclosure;

FIG. 21 depicts a flow diagram of a method of in-flight transfer of payloads between a pair of autonomous drones in accordance with some embodiments of this disclosure; and

FIG. 22 depicts another flow diagram of a method of in-flight transfer of payloads between a pair of autonomous drones in accordance with some embodiments of this disclosure.

DETAILED DESCRIPTION

Embodiments of the present disclosure are directed to a system for in-flight transferring of packages or payloads between a pair of autonomous drones. Embodiments of the present disclosure provide for the delivery of a payload beyond the range or authorized area of operation for a single autonomous drone. Some embodiments of the present disclosure further provide for cooperation between multiple autonomous drones in the delivery of a payload from an originating location, such as a warehouse for example, to a final destination, such as a customer's home for example.

Referring now to FIG. 1, an embodiment is shown of an autonomous drone 20 or unmanned aerial vehicle. As used herein, the term "drone" refers to an aerial vehicle capable to operating autonomously from a human operator to perform a predetermined function, such as deliver a payload or package for example. The drone 20 includes a fuselage 22 that supports at least one thrust device 24. In an embodiment, the drone 20 includes a plurality of thrust devices 24A, 24B, such as four thrust devices arranged about the periphery of the fuselage 22. In an embodiment, the thrust devices 24 include propeller member that rotates to produce thrust. The thrust devices 24 may be configurable to provide both lift (vertical thrust) and lateral thrust (horizontal thrust). The vertical and horizontal components of the thrust allow the changing of the altitude, lateral movement and orientation (attitude) of the drone 20.

In the exemplary embodiment, the fuselage 22 and thrust devices 24 are sized and configured to carry a payload 26 or package. The payload 26 being releasably coupled to the fuselage 22 by a first tether 28. As will be discussed in more detail herein, the payload 26 may also be coupled to a second tether 30. The second tether 30 is coupled on one end to the payload 26 and on an opposite end 32 to a transfer member 34. In the exemplary embodiment, the transfer member 34 is a transfer arm that extends from a side of the fuselage 22. In an embodiment, the transfer arm may be an expandable or extendable member that may be extended or retracted for the payload transfer process. The expandable transfer arm may be actuated by hydraulic, pneumatic, electromechanical (motor with a power screw) or with magnetic (solenoid or linear actuator) assemblies.

In an embodiment, the end 32 is movably or slidably coupled to the transfer member 34 to allow the end 32 to move from the transfer member 34 to another transfer member on another drone or a stationary docking station. In an embodiment, the movement of the end 32 is under the influence of gravity. In an embodiment, the transfer member 34 includes a coupling device 36. As discussed herein, in

some embodiments the coupling device 36 engages a coupling device on another drone during the package transfer process to maintain the pair of drones in a fixed relationship during the transfer process. In the exemplary embodiment, the coupling device 36 is an electromagnet. In other embodiments the coupling device 36 may be any suitable mechanical, electro-mechanical or magnetic mechanism for engaging another drone.

The drone 20 includes a controller 38 having a processing circuit. The controller 38 may include processors that are responsive to operation control methods embodied in application code such as those shown in FIGS. 14-15. These methods are embodied in computer instructions written to be executed by the processor, such as in the form of software. The controller 38 is coupled transmit and receive signals from the thrust devices 24, the transfer member 34 and the coupling device 36 to determine and change their operational states (e.g. extend transfer member 34, change polarity of coupling device 36, adjust lift from thrust devices 24). The controller 38 may further be coupled to one or more sensor devices that enable to the controller to determine the position, orientation and altitude of the drone 20. In an embodiment, these sensors may include an altimeter 40, a gyroscope or accelerometers 42 or a global positioning satellite (GPS) system 44.

FIG. 2 illustrates a block diagram of a controller 38 for use in implementing a system or method according to some embodiments. The systems and methods described herein may be implemented in hardware, software (e.g., firmware), or a combination thereof. In some embodiments, the methods described may be implemented, at least in part, in hardware and may be part of the microprocessor of a special or general-purpose controller 38, such as a personal computer, workstation, minicomputer, or mainframe computer.

In some embodiments, as shown in FIG. 2, the controller 38 includes a processor 105, memory 110 coupled to a memory controller 115, and one or more input devices 145 and/or output devices 140, such as peripheral or control devices, that are communicatively coupled via a local I/O controller 135. These devices 140 and 145 may include, for example, battery sensors, position sensors (altimeter 40, accelerometer 42, GPS 44), indicator/identification lights and the like. Input devices such as a conventional keyboard 150 and mouse 155 may be coupled to the I/O controller 135 when the drone is docked to allow personnel to service or input information. The I/O controller 135 may be, for example, one or more buses or other wired or wireless connections, as are known in the art. The I/O controller 135 may have additional elements, which are omitted for simplicity, such as controllers, buffers (caches), drivers, repeaters, and receivers, to enable communications.

The I/O devices 140, 145 may further include devices that communicate both inputs and outputs, for instance disk and tape storage, a network interface card (NIC) or modulator/demodulator (for accessing other files, devices, systems, or a network), a radio frequency (RF) or other transceiver, a telephonic interface, a bridge, a router, and the like.

The processor 105 is a hardware device for executing hardware instructions or software, particularly those stored in memory 110. The processor 105 may be a custom made or commercially available processor, a central processing unit (CPU), an auxiliary processor among several processors associated with the controller 38, a semiconductor based microprocessor (in the form of a microchip or chip set), a macroprocessor, or other device for executing instructions. The processor 105 includes a cache 170, which may include, but is not limited to, an instruction cache to speed up

executable instruction fetch, a data cache to speed up data fetch and store, and a translation lookaside buffer (TLB) used to speed up virtual-to-physical address translation for both executable instructions and data. The cache **170** may be organized as a hierarchy of more cache levels (L1, L2, etc.).

The memory **110** may include one or combinations of volatile memory elements (e.g., random access memory, RAM, such as DRAM, SRAM, SDRAM, etc.) and nonvolatile memory elements (e.g., ROM, erasable programmable read only memory (EPROM), electronically erasable programmable read only memory (EEPROM), programmable read only memory (PROM), tape, compact disc read only memory (CD-ROM), disk, diskette, cartridge, cassette or the like, etc.). Moreover, the memory **110** may incorporate electronic, magnetic, optical, or other types of storage media. Note that the memory **110** may have a distributed architecture, where various components are situated remote from one another but may be accessed by the processor **105**.

The instructions in memory **110** may include one or more separate programs, each of which comprises an ordered listing of executable instructions for implementing logical functions. In the example of FIG. **2**, the instructions in the memory **110** include a suitable operating system (OS) **111**. The operating system **111** essentially may control the execution of other computer programs and provides scheduling, input-output control, file and data management, memory management, and communication control and related services.

Additional data, including, for example, instructions for the processor **105** or other retrievable information, may be stored in storage **120**, which may be a storage device such as a hard disk drive or solid state drive. The stored instructions in memory **110** or in storage **120** may include those enabling the processor to execute one or more aspects of the systems and methods of this disclosure.

The controller **38** may further include a display controller **125** coupled to a user interface or display **130**. In some embodiments, the display **130** may be an LCD screen. In other embodiments, the display **130** may include a plurality of LED status lights. In some embodiments, the controller **38** may further include a network interface **160** for coupling to a network **165**. The network **165** may be an IP-based network for communication between the controller **38** and an external server, client and the like via a broadband connection. In an embodiment, the network **165** may be a satellite network. The network **165** transmits and receives data between the controller **38** and external systems. In an embodiment, the external system may be another aerial drone or a drone docking system, wherein the transmitting and receiving of data allows the controller **38** to identify the other drone or docking system and determine when the payload is to be transferred to the other drone. In some embodiments, the network **165** may be a managed IP network administered by a service provider. The network **165** may be implemented in a wireless fashion, e.g., using wireless protocols and technologies, such as WiFi, WiMax, satellite, etc. The network **165** may also be a packet-switched network such as a local area network, wide area network, metropolitan area network, the Internet, or other similar type of network environment. The network **165** may be a fixed wireless network, a wireless local area network (LAN), a wireless wide area network (WAN) a personal area network (PAN), a virtual private network (VPN), intranet or other suitable network system and may include equipment for receiving and transmitting signals.

Systems and methods according to this disclosure may be embodied, in whole or in part, in computer program products or in controller **38**, such as that illustrated in FIG. **2**.

Referring now to FIG. **3**, an embodiment is shown of a package or payload delivery system **200** that uses autonomous drones, such as drone **20** for example, to deliver a payload from an originating location **202** (e.g. a warehouse) to a final destination **204** (e.g. a customer). In an embodiment, the system **200** is configured to provide delivery of the payload **26** to destination locations where the drone **20** that initially receives the payload is unable to complete the delivery. The drone **20** may be unable to complete the delivery for a variety of reasons, for example, the destination location **204** may be beyond the range of the drone **20** (e.g. too far way). The drone **20** may not be able to complete the delivery for other reasons as well; the use of the drone **20** may be restricted by governmental regulations or due to geographic restrictions by contracts between parties for example. In still other embodiments, the destination location **204** may only allow deliveries from approved drones.

In this embodiment, the system **200** provides for the in-flight transfer of the payload **26** from an initial drone **20** to one or more intermediate drones **206**, **208** or a docking system **210**. The system **200** provides for the in-flight transfer to allow the drones **20**, **206**, **208** to transfer the payload **26** without landing and therefore improving the efficiency of the delivery. In an embodiment, the system **200** includes a communication system **212** that allows the transmission of signals to the drones **20**, **206**, **208**, such as through a satellite based communications link **214**. It should be appreciated that the communications link **214** may be cellular, radio frequency or a mesh communications type network. The signals transmitted to the drones **20**, **206**, **208** may include locations to pick up, transfer or deliver the payload, or the size and weight of the payload for example. The signals transmitted to the drones **20**, **206**, **208** may further include identification information that allows the carrying drone (e.g. drone **20**) to dynamically identify the receiving drone (e.g. drone **206**) prior to engaging in the in-flight transfer process.

Referring now to FIGS. **4-7** an embodiment of a drone **220** is shown that is configured to carry a payload **26** and perform an in-flight transfer of the payload **26** to another drone **240** or a docking platform **210**. The drone **220** as the original carrier of the payload **26** may be referred to as the originating drone. In this embodiment, the drone **220** includes a plurality of thrust devices **222** that provide lift, horizontal thrust and orientation control. A transfer arm **224** extends from the fuselage **226**. It should be appreciated that the transfer arm **224** is positioned as to not interfere with the thrust devices **222**. In the exemplary embodiment, the transfer arm **224** is extendable and retractable. In embodiments, this provides for a more aerodynamic profile and reduces drag to increase efficiency and range. On the end of the transfer arm **224** is a coupler device **228**, such as an electromagnet. As discussed above the transfer arm **224** and coupler device **228** may be controlled by the controller **38**. In an embodiment, the controller **38** may change the polarity of the electromagnet to allow the coupler device **228** to engage another coupler device.

The payload **26** is coupled to the fuselage **226** by a first tether **230**. In an embodiment, the payload **26** is releasably coupled to the first tether **230**, such as at end **232** for example. The release device for payload **26** may be reusable (e.g. a magnetic based system) or a one-time usage (e.g. the first tether **230** is severed or includes a frangible joint). The payload **26** is further coupled to a second tether **234**. The

second tether **234** includes an end **236** that is slidably coupled to the transfer arm **224**. In an embodiment, the end **236** includes a capture ring **238**. The capture ring **238** may be sized to allow the capture ring **238** to freely move along the length of the transfer arm **224**.

In operation, the originating drone **220** receives a payload **26** (i.e. from a warehouse or another drone) and travels to the location of the transfer. In an embodiment, the originating drone **220** receives data, such as upon receiving the payload **26** or while enroute to the transfer location, that indicates the identity of the receiving drone **240** or docking platform **210**. Upon reaching the transfer location, the originating drone **220** identifies the receiving drone **240**. The identification may occur via radio frequency (RF) communication for example. In one embodiment, each of the drones **220**, **240** have a transponder that communicates an identification signal. In an embodiment, the drones **220**, **240** may include a radio frequency identification device (RFID) that transmits the identification signal. In other embodiments, the identification may occur optically, such as via a camera that is used to acquire images of the other drone and the markings are visually compared to determine identification. In still other embodiments, the drones **220**, **240** may include lights or LED's that are used to transmit an identification signal to the other drones.

In this embodiment, the receiving drone **240** also includes a transfer arm **242** having a coupling device **244** arranged on the end. The transfer arm **242** may be extendible and retractable as discussed herein with respect to arm **224**. Once the identification has been validated, the drones **220**, **240** align their fuselages **226**, **246** such that the transfer arms **224**, **242** and coupling devices are aligned. The alignment of the transfer arms **224**, **242** may be accomplished by adjusting the respective thrust devices **222**, **248**. Once aligned, the drones **220**, **240** engage the coupling devices **228**, **244** (FIG. 5). Once the coupling devices **228**, **244** are engaged, the drones **220**, **240** are fixedly coupled to each other. In an embodiment, the respective controllers **38** establish a communication linkage, such as via radio frequency or a data connection in the coupling devices **228**, **244** for example, that allows the controllers **38** to cooperate and maintain a coordinated altitude and orientation.

At the point of engagement, the capture ring **238** is positioned on the transfer arm **224** of the originating drone **220**. The drones **220**, **240** then change their respective orientations (FIG. 6) to tilt or angle the coupled transfer arms **224**, **242** to allow the capture ring **238** to move or slide along the length of the transfer arms **224**, **242** from the transfer arm **224** to the transfer arm **242** under the influence of gravity. It should be appreciated that once the capture ring **238** moves, the payload **26** is coupled to the originating drone **220** by the first tether **230** and to the second drone **240** by the second tether **234**.

In an embodiment, the controllers **38** determine the change in orientation to allow the capture ring **238** to move and for the payload to transfer based on the weight of the payload, a desired transfer rate, and a length of transfer. Other variables may include factors such as the coefficient of friction between the capture ring **238** and the transfer arms **224**, **242**. The controllers **38** then determine a mass transfer time-dependent differential vector. For example, it may be known that a **250g** payload is to be transferred at a rate of **3 cm/second** over a span of **30 cm**. From this differential vector, an orientation or altitude adjustment may be determined to provide a desired or predetermined transfer rate or dynamic load shifting. As discussed further herein, the drones **220**, **240** may include dynamic counterbalancing.

The determined differential vector may be used to determine the timing and amount of dynamic counterbalancing that is applied.

With the capture ring **238** moved, the drones **220**, **240** again adjust their orientations, such as to a relatively horizontal position for example, and disengage the coupling devices **228**, **244** (FIG. 7). The originating drone **220** may then release the payload **26** resulting in the payload **26** being coupled to the receiving drone **240** by the second tether **234**. Once released, the payload **26** moves into alignment with the receiving drone **240**. In an embodiment, the receiving drone **240** may couple a third tether **250** to secure the payload **26**. The drones **220**, **240** may then retract their respective transfer arms **224**, **242** and proceed to their next destination.

It should be appreciated that the transferring of the payload **26** from the originating drone **220** to the receiving drone **240** results in a transfer of weight from one drone to the other. During the transition period during which the payload is being transferred, the center of gravity of each respective drone **220**, **240** will be dynamically changing as the weight shifts from one drone to the other. In an embodiment, the controllers **38** compensate for the dynamic changing of the center of gravity by adjusting the thrust devices **222**, **248**. In an embodiment where the drones **220**, **240** have a plurality of thrust devices **222**, **248** (e.g. four thrust devices arranged about the periphery of the drone), the controllers **38** may adjust individual thrust devices **222**, **248** differently and continuously during the transfer process of payload **26** to maintain a predetermined altitude and orientation.

In another embodiment shown in FIG. 8, the drones include a dynamic counterbalance member **252** in the form of a second arm **258** that is arranged opposite the transfer arm **242**. The second arm **258** may be extendible or retractable in the direction indicated by arrow **256**. A weight member **254** is disposed on the end of the second arm **258**. It should be appreciated that as the second arm **258** is extended further from the center of the fuselage **246**, the center of gravity of the drone **240** will shift in the direction of the weight member **254**. Since the weight of the payload **26** is being transferred onto the transfer arm **242**, the controller **38** may extend or retract the second arm **258** to compensate for the payload **26** and maintain the center of gravity of the drone **240** in a desired location or range of locations.

In another embodiment shown in FIG. 9, another the counterbalance member **252** is shown having a plurality of ballast tanks **260A**, **260B**, **260C** that contain a balancing fluid. The ballast tanks **260A**, **260B**, **260C** may be disposed within the fuselage **246** or suspended below the fuselage **246** for example. The counterbalance member **252** further includes pumps **262** that are configured to transfer a fluid between the center ballast tank **260A** and the outer ballast tanks **260B**, **260C**. In this embodiment, to compensate for the weight from the payload **26**, the controller **38** may activate the pumps **260** to move fluid from the center ballast tank **260A** to one or more of the outer ballast tanks **260B** for example, to maintain the center of gravity in a desired location. In the illustrated embodiment, as the weight of the payload **26** is transferred onto the transfer arm **242**, the fluid is moved from the ballast tank **260A**, **260C** towards the ballast tank **260B**.

In an embodiment, the drone may use a combination of the above counterbalancing arrangements during operation.

It should be appreciated that while embodiments herein describe and illustrate the transfer process with respect to a single payload **26**, in other embodiments, the transfer process may include multiple payloads. Referring now to FIG.

10, an embodiment is shown wherein the originating drone 220 is carrying multiple payloads 26A, 26B. Each of the payloads 26A, 26B may be individually coupled to the fuselage 226 by the first tether 230, or may be jointly coupled. Each payload 26A, 26B is coupled by a separate second tether 234A, 234B. Each second tether 234A, 234B includes a capture ring 238A, 238B. To transfer the payloads 26A, 26B, the drones 220, 240 perform the steps discussed herein with respect to FIGS. 4-7. It should be appreciated however, that the drones 220, 240 may also be configured to transfer one of the payloads, such as payload 26B for example, from the originating drone to the receiving drone 240. In an embodiment, the capture rings 238A, 238B may be selectively coupled to the transfer arm 224 to retain the capture ring and prevent it from moving onto the transfer arm of the receiving drone 240. In this manner, the retained payload (e.g. payload 26A) may be retained on the originating drone 220 while the other payload (e.g. payload 26B) is transferred to the receiving drone 240.

Referring now to FIG. 11 an embodiment of an arrangement for engaging the coupling devices 228, 244. In this embodiment, the end of the transfer arm 242 of the receiving drone 240 includes a cone member 264. The cone member 264 has a generally frustoconical shaped interior having a distal end 266 that is larger than the end 268 proximate the coupling device 244. In this embodiment, as the drones 220, 240 approach each other, the transfer arm 224 and the coupling device 228 are received by the end 266 of the cone member 264. The angled shape of the frustoconical inner surface guides the coupling device 228 towards the coupling devices 244. This provides advantages in completing the engagement of the coupling devices 228, 244 in the event there is a misalignment of the drones 220, 240.

Referring now to FIG. 12A, FIG. 12B and FIG. 12C another embodiment is shown of an arrangement for facilitating the coupling of devices 228, 244. In this embodiment, the cone member 264 may include a substantially solid outer cone made from an elastomeric plastic. In an embodiment, the cone member 264 may be reinforced with springs to keep the cone member 264 open. In still another embodiment, the cone member 264 may include substantially rigid parallel/co-axial armatures with webbing arranged between the arms. The arms may be gimballly disposed so that each arm extends/collapses towards the long axis of the cone as the arms are extended/retracted with respect to the housing of the transfer arm 242. In this embodiment, when the drones 220, 240 are to couple, the drone 240 extends the cone member 264 (FIG. 12A). The cone member 264 has a generally frustoconical shaped interior having a distal end 266 that is larger than the end 268 proximate the coupling device 244. The frustoconical shape of the cone member guides the coupling device 228 towards the coupling device 244 (FIG. 13A). After the coupling device 228 is coupled to the device 244, the drone 240 may retract the cone member 264 (FIG. 12B) until the cone member 264 is disposed within transfer arm 242 (FIG. 12C, FIG. 13B). With the coupling devices 228, 244 connecting the drones 220, 240, the transfer of the payload 26 may be initiated.

Referring now to FIG. 14A, an embodiment of a system is shown for assisting the transfer of the payload 26 from the originating drone 220 to the receiving drone 240. In this embodiment, the receiving drone 240 includes a transfer sleeve 400 that moves from a retracted position (e.g. within a housing on the drone 240) to an extended position. The transfer sleeve 400 is generally tubular in shape having a hollow interior that is sized to receive the transfer arm 242. On an end 402, the transfer sleeve 400 includes a pickup

member 404 that moves with the transfer sleeve 400 as the transfer sleeve is extended and retracted. The transfer sleeve 400 is sized to extend over the transfer arm 224 (FIG. 14A) until the pickup member 404 is proximate the capture ring 238 (FIG. 14B).

In an embodiment, the pickup member 404 and the capture ring 238 are configured to interlock and couple when the members 404, 406 are proximate each other. In one embodiment, the interlock may be formed by an electromagnet. In another embodiment, the interlock may be formed by a mechanical means, such as a spring-loaded latch for example. Once the member 404 and capture ring 238 are interlocked, the transfer sleeve is retracted such that the end 402 moves towards the fuselage of the drone 240. As the transfer sleeve 400 is retracted, the interlocking of the member 404 and capture ring 238 causes the payload 26 to move away from the originating drone 220 and towards the receiving drone 240 (FIG. 14C). In one embodiment, the use of the transfer sleeve 400 allows for the transfer of the payload from the originating drone 220 to the receiving drone 240 without reorienting (angling) the drones 220, 240. In another embodiment, the use of the transfer sleeve 400 reduces the amount of orientation change used in the transfer process.

When the transfer sleeve 400 is fully retracted (FIG. 14D), the member 404 and capture ring 238 are disposed on the transfer arm 242 and the transfer of the payload 26 from the originating drone 220 to the receiving drone 240 is completed. The coupling device 228 may then disengage from the coupling device 244 allowing the drones 220, 240 to separate. The payload 26 may then be secured to the receiving drone 240 as discussed herein.

Referring now to FIG. 15A, another embodiment is shown for transferring the payload 26 from the originating drone 220 to the receiving drone 240. This embodiment is similar to that of FIG. 14A with the receiving drone 240 having a transfer sleeve 400 that is extendable and retractable over the transfer arms 224, 242. The transfer sleeve 400 includes a pickup member 404 disposed on an end 402. In this embodiment, the originating drone 220 also includes a transfer sleeve 410. The transfer sleeve 410 is also movable between an extended position and a retracted position. On one end 412, a pickup member 414 is coupled to the transfer sleeve 410. The transfer sleeve 410 is generally tubular in shape having a hollow interior that is sized to receive the transfer arm 224.

In the exemplary embodiment, the pickup member 414 includes an interlock device, such as an electromagnet or a mechanical locking means (e.g. a spring-loaded latch) for example, that couples the pickup member 414 to the capture ring 238 (FIG. 15A). As the transfer sleeve 410 moves from the retracted position to the extended position, the capture ring 238, and thus the payload 26 are moved along the transfer arm 224. When the originating drone 220 is coupled to the receiving drone 240, the capture ring 238 and payload 26 are moved towards the receiving drone 240. It should be appreciated that movement of the capture ring 238 with the pickup member 414 may also be used at the point of delivery to slide the capture ring 238 off the transfer arm 224 to disconnect the payload 26 from the originating drone 220.

As the capture ring 238 is moved it will come into contact with the pickup member 404 from the receiving drone (FIG. 15B). The interlock device of pickup member 404 (e.g. an electromagnet) couples with the capture ring 238 resulting in the capture ring 238 being coupled to both pickup members 404, 414. Once the capture ring 238 is coupled to the pickup members 404, 414, the transfer sleeve 410 continues to

11

extend while the transfer sleeve **400** retracts. This allows the movement of the capture ring **238** from the transfer arm **224** onto the transfer arm **242** (FIG. **15C**). At this point, the weight of payload **26** has been transferred from the originating drone **220** to the receiving drone **240**.

When the transfer sleeve **400** is fully retracted (FIG. **15D**), the member **404** and capture ring **238** are disposed on the transfer arm **242** and the transfer of the payload **26** from the originating drone **220** to the receiving drone **240** is completed. The coupling device **228** may then disengage from the coupling device **244** allowing the drones **220**, **240** to separate. The payload **26** may then be secured to the receiving drone **240** as discussed herein.

Referring now to FIG. **16** another embodiment of a system for moving the capture ring **238** from the originating drone **220** to the receiving drone **240** without using or without relying on gravity. In this embodiment, the receiving drone **240** includes a hook member **270** that extends from or along the transfer arm **242**. The hook member **270** includes a curved end **272** having an end **276** that defines an open section **274**. In this embodiment, when the transfer arms **224**, **242** are engaged, the hook member **270** extends and routes the end **276** through the opening defined by the capture ring **238**. This allows the capture ring **238** to pass through the open section **274** and be captured by the hook member **270**. The hook member **270** may then be retracted resulting in the loop member being moved from the transfer arm **224** of the originating drone **220** to the transfer arm **242** of the receiving drone **240**.

It should be appreciated that other mechanisms may be used to transfer the capture ring **238**, such as but not limited to a conveyor means, a motor-driven means, a pulley system, an electromagnetic means and other mechanical means.

Referring now to FIG. **17** another embodiment is shown for transferring a payload **26** from an originating drone **300** to a receiving drone **302**. Both the originating drone **300** and the receiving drone **302** include a plurality of thrust devices **301**, **303**. In this embodiment, the originating drone **300** includes a movable transfer member **304** arranged above the fuselage **306**. The transfer member **304** includes a set of transfer posts **308** that move the payload **26** from a first position within the fuselage **306** to a second position for transfer. In an embodiment, the transfer posts **308** are configured to extend through and are movable the fuselage **306**. As will be discussed in more detail below, the extension of the transfer posts **308** through the fuselage **306** allows drones **300**, **302** to use the transfer posts **308** for both passing and receiving the payload **26**. In an embodiment, the transfer member **304** also includes a guide plate **309** that is movable between an open position (when receiving a payload) and a closed position (when flying or passing the payload). In an embodiment, the payload **26** is arranged within a cargo cage.

The receiving drone **302** includes a transfer member **310**. In an embodiment, the receiving drone **302** is configured and constructed substantially identical to the originating drone **300**. The drone **302** includes a transfer member **310** having a plurality of transfer posts **311** that are movable between a raised position over the fuselage **312** and a lowered position. The transfer member **310** further includes a guide plate **313** that is movable between a closed position and an open position. In an embodiment, the guide plate **313** includes a plurality of plates.

Referring now to FIGS. **14A-14D**, the sequence or process for transferring the payload between the originating drone **300** and the receiving drone **302** is shown. After performing the identification authentication discussed herein, the drones **300**, **302** first prepare and reconfigure for

12

the transfer. The originating drone **300** extends the transfer posts **308** causing the payload **26** to move from within the fuselage **306** to a position vertically above the fuselage **306** (FIG. **18A**). At this point, the receiving drone **302** also opens the guide plates **313** to define an opening in the fuselage **312** that is sized to receive the package **26**.

Next the drones **300**, **302** align vertically to each other. As the receiving drone **302** lowers over the originating drone **300**, the guide plates align the elevated cargo cage on originating drone **300** with cargo hold in the fuselage **312** (FIG. **18B**). As the receiving drone **302** approaches the payload **26**, locking plates **314** (FIG. **18C**) engage the cargo cage of payload **26**. The locking plates **314** secure the payload to the receiving drone **302**. Once the locking plates **314** are engaged with the top of the cargo cage, the originating drone **300** releases the cargo cage. With the payload **26** secured to the receiving drone **302**, the drones **300**, **302** disengage and separate (FIG. **18D**).

In an embodiment, at the point of separation, the payload **26** is disposed vertically below the receiving drone **302**. Referring now to FIGS. **19A-19D**, a sequence of process for securing the stowing the payload **26** within the receiving drone **302**. To stow the payload **26**, the drone **302** first lowers the transfer posts **311** to a lowered position extending below the fuselage **312**. Each transfer post **311** includes a latch member **315** that engages and locks onto the cargo cage of payload **26** (FIG. **19A**). The transfer posts **311** are then moved raising the payload **26** into the cargo area within the fuselage **312**. It should be appreciated that before the payload **26** is raised, the latching plates **313** are disengaged and then re-engaged when the payload **26** is within the fuselage **312**. In an embodiment, after the latching plates **313** are re-engaged the transfer posts **311** are lowered to an intermediate position.

The guide plates **313** are then moved to a closed position, enclosing the bottom of the fuselage **312** (FIG. **19C**). At this point, the payload **26** is secured and the drone **302** is ready to continue the delivery process (FIG. **19D**).

In some embodiments, one issue that may be encountered with vertical package transfer configuration is the thrust/lift reduction for the thrust devices **301** on the lower drone **300** shown in FIG. **20** while it is hovering below the upper drone **302** due to the airflow caused by the thrust devices **303**. In one embodiment, the reduction in thrust/lift for the thrust devices **301** on the lower drone **300** can be compensated by increasing the rotor speed of the thrust device **301**. In another embodiment the reduction in thrust/lift for the thrust devices **301** on the lower drone **300** can be compensated by adjusting the angled thrust device mounts **316**, **317** on both drones **300**, **302** to increase the clean air stream available to the rotors on the lower drone **300**. The angling of the thrust device mounts **316** may be angled such that the downwash air flow is beneath the drone **300** as indicated by arrows **318**. The thrust device mounts **317** are then angled in the opposite manner such that the downwash air flow is directed more outward as indicated by the arrows **319** and not directly onto the lower drone **300**.

It should be appreciated that the transfer of a payload from drone **302** to drone **300** may also be accomplished by performing the transfer process in reverse.

Referring now to FIG. **21**, a method **320** is shown for the in-flight transfer of a payload between drones. The method starts in block **322** and proceeds to block **324** where the drones align themselves to each other. For example, where the drones have transfer arms, the transfer arms are extended and aligned. The method **320** then proceeds to block **326** where the transfer members engage each other to couple the

drones together. In an embodiment, the drones communicate while engaged and cooperate to maintain a desired altitude and orientation. In another embodiment, the drones act in an arrangement wherein one of the drones assumes control of the combined operation of the coupled drones for the duration of the transfer.

The method **320** then proceeds to block **328** where the drones change orientation, such as increasing the altitude of the originating drone to create a slope or angled surface along the length of the engaged transfer arms. When the orientation is changed, a capture ring of a tether slides from the transfer arm of the originating drone to the transfer arm of the receiving drone. In an embodiment, the sliding of the capture ring occurs due to gravity. In another embodiment, the loop portion movement is caused by a member of either the originating drone or the receiving drone, such as a hook member for example. When the loop portion is coupled to the receiving drone, the originating drone releases the payload tether, allowing the payload to move under the influence of gravity. In some embodiments, the payload will fall away from the originating drone for a short distance before the tension of the tether connected to the receiving drone causes the payload to swing under the receiving drone.

With the payload transferred to the receiving drone, the method **320** proceeds to block **332** where the originating drone and receiving drone disengage. In the embodiment where one of the drones assumes control of both drones during transfer, the control for the other drone is released back to the controller of that drone prior to disengagement. The method **320** then proceeds to block **334** where the drones continue on with the delivery activity.

Referring now to FIG. **22**, another method **340** is shown for the in-flight transferring of a payload from an originating drone to a receiving drone. In this embodiment, the method **340** starts in block **342** and proceeds to block **344** where the originating drone validates the identity of the receiving drone to ensure that the payload is being transferred to the correct drone. This identification may be performed using a radio frequency communication of an ID code for example. The method **340** then proceeds to block **346** where the drones are aligned to initiate the payload transfer. In block **348** the drone controllers determine a mass transfer time-dependent differential vector. The differential vector provides a model for the controllers to predict the impact of the transfer on the drones (such as for counterbalancing for example) and may also be used to define the orientation or other flight parameters that the drones will use to make the transfer efficient. In an embodiment, the method **340** then proceeds to block **350** where the originating drone and the receiving drone engage and are coupled together. The method **340** then proceeds to block **352** where the drones change orientation to allow the tether to move from the originating drone to the receiving drone. It should be appreciated that block **350** and block **352** may be omitted in embodiments where the drones do not engage each other, such as where the receiving drone has a transfer member with a net that catches the payload.

The method **340** then proceeds to block **354** where the payload is transferred from the originating drone to the receiving drone. Once the payload transfer is completed, the drones disengage in block **356**. The method **340** ends in block **358** with the drone continuing the delivery activities.

It should be appreciated that while embodiments herein describe the package transfer process in terms of a transfer between a pair of aerial drones, the claims should not be so limited. In other embodiments, the transfer may be between an aerial drone and a stationary object, such as a roof of a

building, a drone docking station or other structure configured to receive payloads. The transfer of the payload to a stationary structure while keeping the drone airborne provides similar advantages in efficiency of operation as between two aerial drones.

Technical effects and benefits of some embodiments include the efficient in-flight transfer of payloads from an originating drone to a receiving drone to allow the delivery of a payload where the originating drone is unable to travel to the end destination.

The terminology used herein is for the purpose of describing particular embodiments only and is not intended to be limiting of the invention. As used herein, the singular forms “a”, “an” and “the” are intended to include the plural forms as well, unless the context clearly indicates otherwise. It will be further understood that the terms “comprises” and/or “comprising,” when used in this specification, specify the presence of stated features, integers, steps, operations, elements, and/or components, but do not preclude the presence or addition of one or more other features, integers, steps, operations, elements, components, and/or groups thereof.

The corresponding structures, materials, acts, and equivalents of all means or step plus function elements in the claims below are intended to include any structure, material, or act for performing the function in combination with other claimed elements as specifically claimed. The description of the present invention has been presented for purposes of illustration and description, but is not intended to be exhaustive or limited to the invention in the form disclosed. Many modifications and variations will be apparent to those of ordinary skill in the art without departing from the scope and spirit of the invention. The embodiments were chosen and described in order to best explain the principles of the invention and the practical application, and to enable others of ordinary skill in the art to understand the invention for various embodiments with various modifications as are suited to the particular use contemplated.

The present invention may be a system, a method, and/or a computer program product. The computer program product may include a computer readable storage medium (or media) having computer readable program instructions thereon for causing a processor to carry out aspects of the present invention.

The computer readable storage medium can be a tangible device that can retain and store instructions for use by an instruction execution device. The computer readable storage medium may be, for example, but is not limited to, an electronic storage device, a magnetic storage device, an optical storage device, an electromagnetic storage device, a semiconductor storage device, or any suitable combination of the foregoing. A non-exhaustive list of more specific examples of the computer readable storage medium includes the following: a portable computer diskette, a hard disk, a random access memory (RAM), a read-only memory (ROM), an erasable programmable read-only memory (EPROM or Flash memory), a static random access memory (SRAM), a portable compact disc read-only memory (CD-ROM), a digital versatile disk (DVD), a memory stick, a floppy disk, a mechanically encoded device such as punch-cards or raised structures in a groove having instructions recorded thereon, and any suitable combination of the foregoing. A computer readable storage medium, as used herein, is not to be construed as being transitory signals per se, such as radio waves or other freely propagating electromagnetic waves, electromagnetic waves propagating through a wave-

guide or other transmission media (e.g., light pulses passing through a fiber-optic cable), or electrical signals transmitted through a wire.

Computer readable program instructions described herein can be downloaded to respective computing/processing devices from a computer readable storage medium or to an external computer or external storage device via a network, for example, the Internet, a local area network, a wide area network and/or a wireless network. The network may comprise copper transmission cables, optical transmission fibers, wireless transmission, routers, firewalls, switches, gateway computers and/or edge servers. A network adapter card or network interface in each computing/processing device receives computer readable program instructions from the network and forwards the computer readable program instructions for storage in a computer readable storage medium within the respective computing/processing device.

Computer readable program instructions for carrying out operations of the present invention may be assembler instructions, instruction-set-architecture (ISA) instructions, machine instructions, machine dependent instructions, microcode, firmware instructions, state-setting data, or either source code or object code written in any combination of one or more programming languages, including an object oriented programming language such as Java, Smalltalk, C++ or the like, and conventional procedural programming languages, such as the "C" programming language or similar programming languages. The computer readable program instructions may execute entirely on the user's computer, partly on the user's computer, as a stand-alone software package, partly on the user's computer and partly on a remote computer or entirely on the remote computer or server. In the latter scenario, the remote computer may be connected to the user's computer through any type of network, including a local area network (LAN) or a wide area network (WAN), or the connection may be made to an external computer (for example, through the Internet using an Internet Service Provider). In some embodiments, electronic circuitry including, for example, programmable logic circuitry, field-programmable gate arrays (FPGA), or programmable logic arrays (PLA) may execute the computer readable program instructions by utilizing state information of the computer readable program instructions to personalize the electronic circuitry, in order to perform aspects of the present invention.

Aspects of the present invention are described herein with reference to flowchart illustrations and/or block diagrams of methods, apparatus (systems), and computer program products according to embodiments of the invention. It will be understood that each block of the flowchart illustrations and/or block diagrams, and combinations of blocks in the flowchart illustrations and/or block diagrams, can be implemented by computer readable program instructions.

These computer readable program instructions may be provided to a processor of a general purpose computer, special purpose computer, or other programmable data processing apparatus to produce a machine, such that the instructions, which execute via the processor of the computer or other programmable data processing apparatus, create means for implementing the functions/acts specified in the flowchart and/or block diagram block or blocks. These computer readable program instructions may also be stored in a computer readable storage medium that can direct a computer, a programmable data processing apparatus, and/or other devices to function in a particular manner, such that the computer readable storage medium having instructions stored therein comprises an article of manufacture including

instructions which implement aspects of the function/act specified in the flowchart and/or block diagram block or blocks.

The computer readable program instructions may also be loaded onto a computer, other programmable data processing apparatus, or other device to cause a series of operational steps to be performed on the computer, other programmable apparatus or other device to produce a computer implemented process, such that the instructions which execute on the computer, other programmable apparatus, or other device implement the functions/acts specified in the flowchart and/or block diagram block or blocks.

The flowchart and block diagrams in the Figures illustrate the architecture, functionality, and operation of possible implementations of systems, methods, and computer program products according to various embodiments of the present invention. In this regard, each block in the flowchart or block diagrams may represent a module, segment, or portion of instructions, which comprises one or more executable instructions for implementing the specified logical function(s). In some alternative implementations, the functions noted in the block may occur out of the order noted in the figures. For example, two blocks shown in succession may, in fact, be executed substantially concurrently, or the blocks may sometimes be executed in the reverse order, depending upon the functionality involved. It will also be noted that each block of the block diagrams and/or flowchart illustration, and combinations of blocks in the block diagrams and/or flowchart illustration, can be implemented by special purpose hardware-based systems that perform the specified functions or acts or carry out combinations of special purpose hardware and computer instructions.

The descriptions of the various embodiments of the present invention have been presented for purposes of illustration, but are not intended to be exhaustive or limited to the embodiments disclosed. Many modifications and variations will be apparent to those of ordinary skill in the art without departing from the scope and spirit of the described embodiments. The terminology used herein was chosen to best explain the principles of the embodiments, the practical application or technical improvement over technologies found in the marketplace, or to enable others of ordinary skill in the art to understand the embodiments disclosed herein.

What is claimed is:

1. A system comprising:

- a first aerial drone having a first transfer member and a first controller, the first transfer member having a coupling device on one end, the first transfer member being configured to carry a payload, the first controller including a processor configured to change a first altitude and first orientation of the first aerial drone;
- a second aerial drone having a second transfer member and a second controller, the second transfer member having a cone member on one end, the second transfer member being configured to receive the payload, the second controller including a processor configured to change a second altitude and a second orientation of the second aerial drone; and

wherein the first controller and the second controller cooperate to change at least one of the first orientation and the second orientation to dispose the coupling device within the cone member and operably engage the first transfer member and second transfer member for transferring the payload from the first transfer member to the second transfer member while the first aerial drone and second drone are in-flight.

17

2. The system of claim 1 wherein the cone member has a frustoconical shaped interior.

3. The system of claim 1, wherein the cone member includes an outer cone made from an elastomeric plastic.

4. The system of claim 1, wherein the cone member includes co-axial arms with webbing arranged therebetween.

5. The system of claim 4, wherein the arms are gimbally disposed and movable between an extended and a collapsed position with respect to a housing of the second transfer member.

6. The system of claim 5, wherein the first controller is operably coupled to change the position of the arms from the extended position to the collapsed position when the first transfer member engages the second transfer member.

7. The system of claim 6, further comprising a transfer sleeve operably coupled to the second transfer member, the transfer sleeve being movable between a retracted position and a second extended position.

8. The system of claim 7, wherein the transfer sleeve has a tubular shape and is disposed about at least a portion of the second transfer member.

9. The system of claim 8, further comprising a pickup member coupled to an end of the transfer sleeve.

10. The system of claim 9, wherein the transfer sleeve is sized, when in the second extended position, to engage the pickup member with a capture ring coupled to the payload.

11. The system of claim 10, further comprising:

a second transfer sleeve operably coupled to the first transfer member, the second transfer sleeve being movable between a second retracted position and a third extended position; and

a second pickup member coupled to an end of the second transfer sleeve.

12. The system of claim 11, wherein the first controller is operably coupled to change the position of the second transfer sleeve from the second retracted position to the third extended position when the first transfer member engages the second transfer member and thereby move the capture ring towards the first pickup member.

13. The system of claim 12, wherein the first pickup member includes an interlock member.

14. The system of claim 13, wherein the interlock member is an electromagnet.

15. The system of claim 13, wherein the second pickup member includes a second interlock member.

18

16. The system of claim 15, wherein the second interlock member is an electromagnet.

17. The system of claim 12, wherein the first controller is operably coupled to disengage the second pickup member from the capture ring when the weight of the payload is transferred to the second aerial drone.

18. The system of claim 17, wherein the first controller is operably coupled to move the second transfer sleeve from the third extended position to the second retracted position when the second pickup member is disengaged from the capture ring.

19. A method of in-flight transferring of a payload between aerial drones, the method comprising:

providing a first aerial drone having a first transfer member;

providing a second aerial drone having a second transfer member, the second transfer member having a cone member;

changing at an orientation of at least one of the first aerial drone and the second aerial drone to position the first transfer member within the cone member;

retracting the cone member into a housing of the second transfer member; and

moving the payload from the first aerial drone to the second aerial drone.

20. The method of claim 19, wherein the moving of the payload further comprises:

extending a first sleeve member operably coupled to the first transfer member from a first retracted position to a first extended position;

moving a capture ring coupled to the payload with the first sleeve member towards the first extended position;

extending a second sleeve member operably coupled to the second transfer member from a second retracted position to a second extended position;

engaging the capture ring with a pickup member coupled to an end of the second sleeve member; and

moving the capture ring from the first transfer member to the second transfer member by moving the second sleeve member from the second extended position to the second retracted position when the capture ring is engaged with the pickup member.

* * * * *