



US010855370B2

(12) **United States Patent**
Tiecke et al.

(10) **Patent No.:** **US 10,855,370 B2**
(45) **Date of Patent:** ***Dec. 1, 2020**

(54) **LUMINESCENT DETECTOR FOR FREE-SPACE OPTICAL COMMUNICATION**

(71) Applicant: **Facebook, Inc.**, Menlo Park, CA (US)

(72) Inventors: **Tobias Gerard Tiecke**, Redwood City, CA (US); **Kevin Jerome Quirk**, Los Altos, CA (US); **Thibault Michel Max Peyronel**, San Francisco, CA (US); **Shih-Cheng Wang**, Cupertino, CA (US)

(73) Assignee: **Facebook, Inc.**, Menlo Park, CA (US)

(*) Notice: Subject to any disclaimer, the term of this patent is extended or adjusted under 35 U.S.C. 154(b) by 0 days.

This patent is subject to a terminal disclaimer.

(21) Appl. No.: **16/588,825**

(22) Filed: **Sep. 30, 2019**

(65) **Prior Publication Data**

US 2020/0036442 A1 Jan. 30, 2020

Related U.S. Application Data

(63) Continuation of application No. 15/662,568, filed on Jul. 28, 2017, now Pat. No. 10,511,383, which is a (Continued)

(51) **Int. Cl.**

H04B 10/00 (2013.01)
H04B 10/11 (2013.01)
H04B 10/25 (2013.01)
H04B 10/66 (2013.01)
H04B 10/112 (2013.01)
G01N 21/64 (2006.01)

(52) **U.S. Cl.**

CPC **H04B 10/11** (2013.01); **G01N 21/64** (2013.01); **H04B 10/112** (2013.01); **H04B 10/25** (2013.01); **H04B 10/66** (2013.01); **G01N 2021/6497** (2013.01)

(58) **Field of Classification Search**

USPC 398/2, 202–214
See application file for complete search history.

(56) **References Cited**

U.S. PATENT DOCUMENTS

4,983,834 A * 1/1991 Lindmayer C09K 11/7786
250/363.01
5,004,913 A * 4/1991 Kleinerman G01J 5/08
250/227.21

(Continued)

Primary Examiner — Agustin Bello

(74) *Attorney, Agent, or Firm* — Arteris Law Group, LLP

(57) **ABSTRACT**

In one embodiment, an apparatus includes a photoluminescent wavelength-shifting material configured to receive an input-light data signal comprising a first range of wavelengths, absorb at least a portion of the received input-light data signal, and produce an emitted-light data signal comprising a second range of wavelengths based on an upper-state lifetime of the photoluminescent wavelength-shifting material. The apparatus also includes a focusing element configured to receive at least a portion of the emitted-light data signal, concentrate the received portion of the emitted-light data signal, and produce a concentrated-light data signal. The apparatus further includes a photodetector configured to receive the concentrated-light data signal, and produce an electrical current corresponding to the concentrated-light data signal.

19 Claims, 8 Drawing Sheets

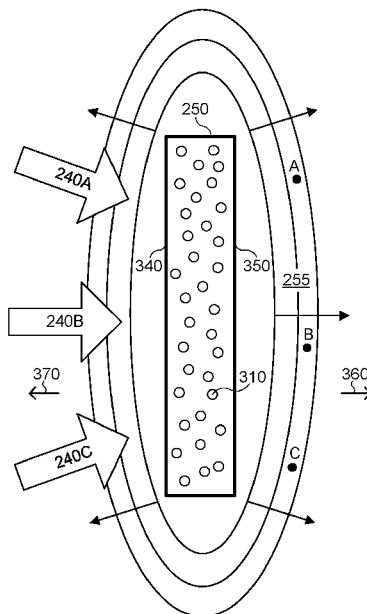

Related U.S. Application Data

continuation of application No. 15/090,786, filed on Apr. 5, 2016, now Pat. No. 9,749,044.

(56)

References Cited

U.S. PATENT DOCUMENTS

5,193,024	A *	3/1993	Lawton	G02F 1/0147	9,544,054	B1 *	1/2017	Tiecke	H04B 10/116
					359/253	9,749,044	B1 *	8/2017	Tiecke	H04B 10/11
6,052,238	A *	4/2000	Ebbesen	B82Y 20/00	9,921,453	B2 *	3/2018	Tiecke	G02F 1/365
					250/227.11	10,050,075	B2 *	8/2018	Creazzo	G02B 5/284
6,236,033	B1 *	5/2001	Ebbesen	B82Y 20/00	10,236,658	B2 *	3/2019	Lenef	H01S 5/183
					250/216	2003/0064532	A1 *	4/2003	Chen	C09K 11/574
6,667,807	B2 *	12/2003	Lieberman	G01N 21/553						438/3
					356/136	2004/0190116	A1 *	9/2004	Lezec	B82Y 20/00
6,834,027	B1 *	12/2004	Sakaguchi	B82Y 10/00						359/298
					250/216	2006/0019265	A1 *	1/2006	Song	G01N 21/01
6,982,819	B2 *	1/2006	Sawin	B82Y 20/00						435/6.19
					359/245	2006/0140240	A1 *	6/2006	Chen	A61K 49/0067
7,057,151	B2 *	6/2006	Lezec	B82Y 20/00						372/69
					250/216	2006/0193550	A1 *	8/2006	Wawro	G01N 21/648
7,167,615	B1 *	1/2007	Wawro	G01N 21/648						385/12
					385/12	2007/0081138	A1 *	4/2007	Kerkhof	G03F 7/706
7,250,598	B2 *	7/2007	Hollingsworth	B82Y 20/00						355/71
					250/234	2007/0187580	A1 *	8/2007	Kykta	G02B 27/017
7,251,085	B2 *	7/2007	Bahatt	G01N 21/553						250/227.15
					356/445	2007/0262714	A1 *	11/2007	Bylsma	G01N 21/31
7,310,153	B2 *	12/2007	Kiesel	G01J 3/26						313/512
					356/454	2008/0018558	A1 *	1/2008	Kykta	G03B 21/567
7,423,254	B2 *	9/2008	Arend	H01L 31/1085						345/58
					250/214 R	2008/0043129	A1 *	2/2008	Li	H01L 27/14621
7,426,040	B2 *	9/2008	Kim	B82Y 20/00						348/308
					356/519	2008/0185521	A1 *	8/2008	Hollingsworth	B82Y 20/00
7,511,285	B2 *	3/2009	Bernstein	B01L 3/502715						250/338.1
					250/461.2	2008/0316485	A1 *	12/2008	Wawro	G01N 21/648
7,773,228	B1 *	8/2010	Hollingsworth	A61B 5/0059						356/328
					250/338.1	2009/0134486	A1 *	5/2009	Fujikata	H01L 31/02240
7,800,193	B2 *	9/2010	Fujikata	H01L 31/1085						257/449
					257/449	2010/0013040	A1 *	1/2010	Okamoto	H01L 31/02240
8,009,356	B1 *	8/2011	Shaner	G02B 27/56						257/432
					359/288	2010/0119192	A1 *	5/2010	Fujikata	B82Y 20/00
8,183,656	B2 *	5/2012	Okamoto	H01L 31/02240						385/14
					257/431	2011/0110628	A1 *	5/2011	Okamoto	H01L 31/1085
8,274,739	B2 *	9/2012	Lee	B82Y 20/00						385/37
					356/454	2012/0012756	A1 *	1/2012	Beck	G01N 21/6489
8,358,419	B2 *	1/2013	Walters	G01N 21/553						250/459.1
					257/443	2013/0146141	A1 *	6/2013	Pelton	G01T 1/20
8,372,476	B2 *	2/2013	Katsuhara	B82Y 20/00						136/259
					356/301	2013/0287333	A1 *	10/2013	Block	B82Y 20/00
8,462,420	B2 *	6/2013	Lee	G02F 1/19						385/12
					359/277	2014/0056559	A1 *	2/2014	Wawro	G01N 21/648
8,466,528	B2 *	6/2013	Okamoto	H01L 31/02325						385/37
					257/432	2014/0063779	A1 *	3/2014	Bradford	F21V 23/0442
8,467,637	B2 *	6/2013	Fujikata	B82Y 20/00						362/84
					257/471	2014/0080225	A1 *	3/2014	Chodavarapu	G01N 21/6408
8,514,391	B2 *	8/2013	Wawro	G01N 21/648						436/172
					356/300	2014/0233885	A1 *	8/2014	Schell	G02B 6/1226
8,582,108	B2 *	11/2013	Walters	G01N 21/553						385/27
					257/443	2015/0244457	A1 *	8/2015	O'Brien	G06F 1/1698
8,749,903	B2 *	6/2014	Yamada	G02B 5/008						398/118
					359/885	2015/0301236	A1 *	10/2015	Nakano	G02B 5/008
8,848,194	B2 *	9/2014	Walters	G01N 21/55						359/589
					356/445	2016/0093760	A1 *	3/2016	Kallos	G02B 6/1226
8,901,514	B2 *	12/2014	Lee	G01N 21/6452						136/259
					250/459.1	2016/0148963	A1 *	5/2016	Creazzo	H01L 27/14627
8,976,360	B2 *	3/2015	Matsuda	B82Y 20/00						257/432
					356/445	2017/0075191	A1 *	3/2017	Tiecke	H04B 10/116
9,063,254	B2 *	6/2015	Block	B82Y 20/00						257/432
						2017/0261313	A1 *	9/2017	Bergren	G01N 21/91
						2017/0346556	A1 *	11/2017	Tiecke	G01N 21/64
						2018/0188609	A1 *	7/2018	Jun	G02F 1/133536
						2018/0356342	A1 *	12/2018	Laycock	G01S 17/74
						2018/0364166	A1 *	12/2018	Laycock	G01N 21/643
						2018/0364168	A1 *	12/2018	Laycock	G01N 21/6408
						2018/0372554	A1 *	12/2018	Laycock	G01K 11/20
						2019/0111522	A1 *	4/2019	Mauersberger	B23K 26/0622
						2020/0036442	A1 *	1/2020	Tiecke	H04B 10/112

* cited by examiner

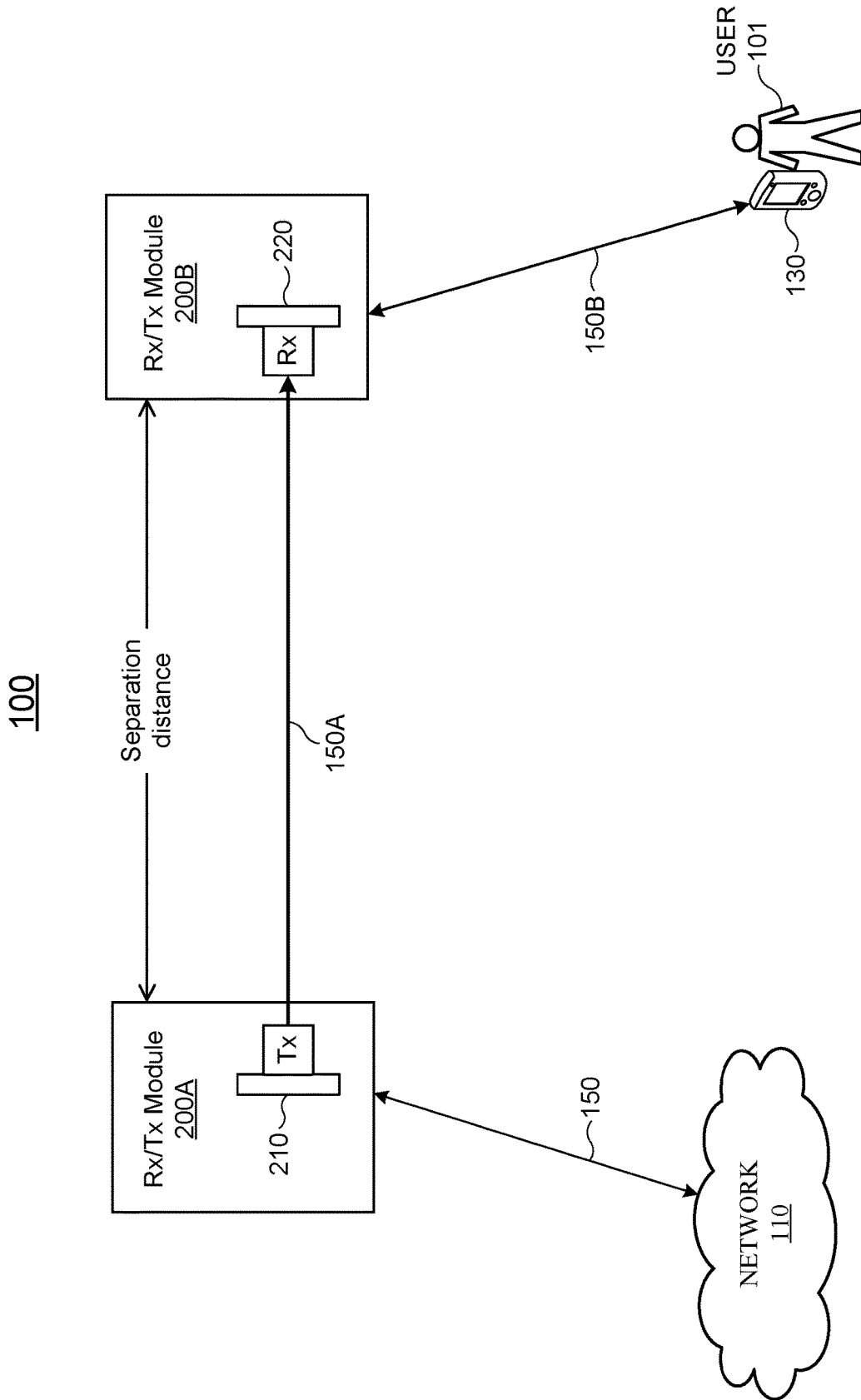

FIG. 1

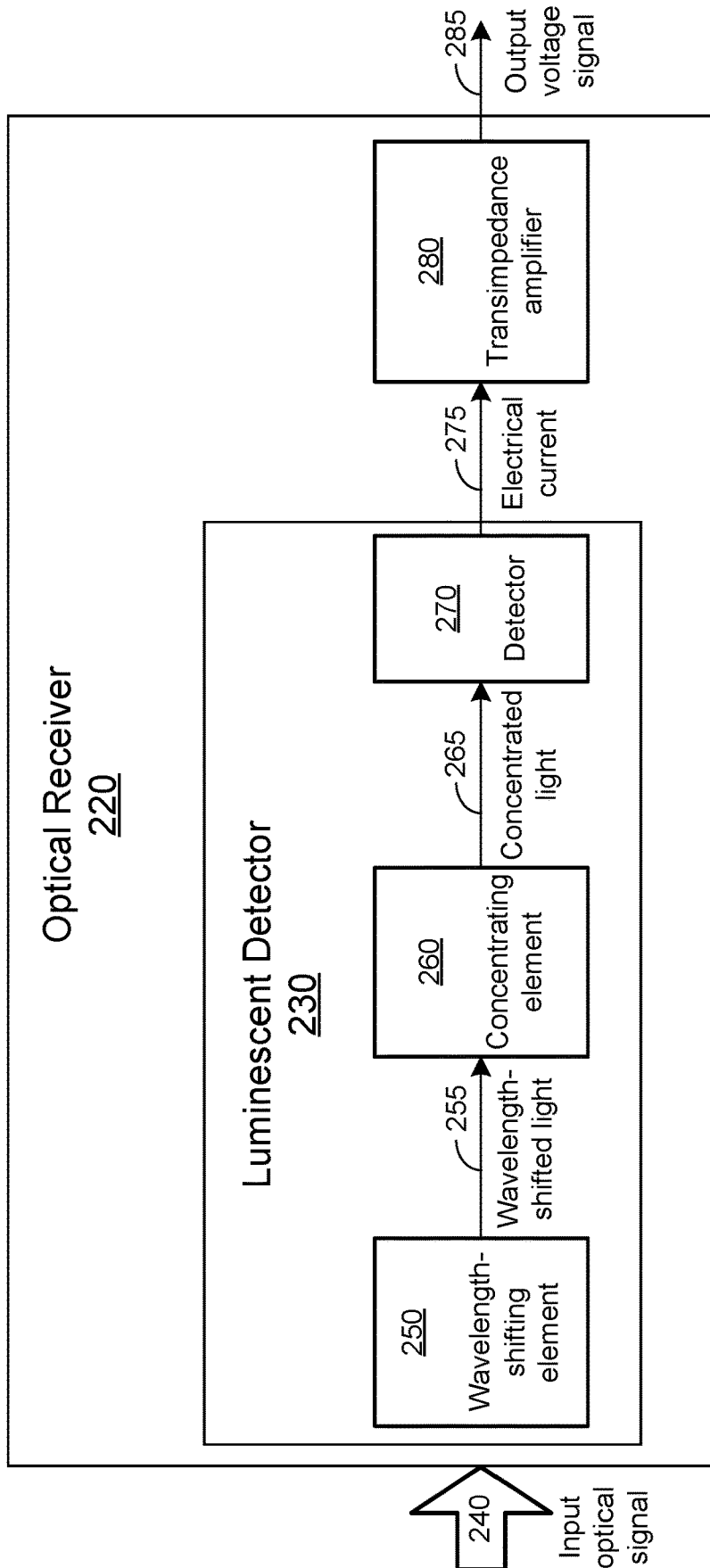

FIG. 2

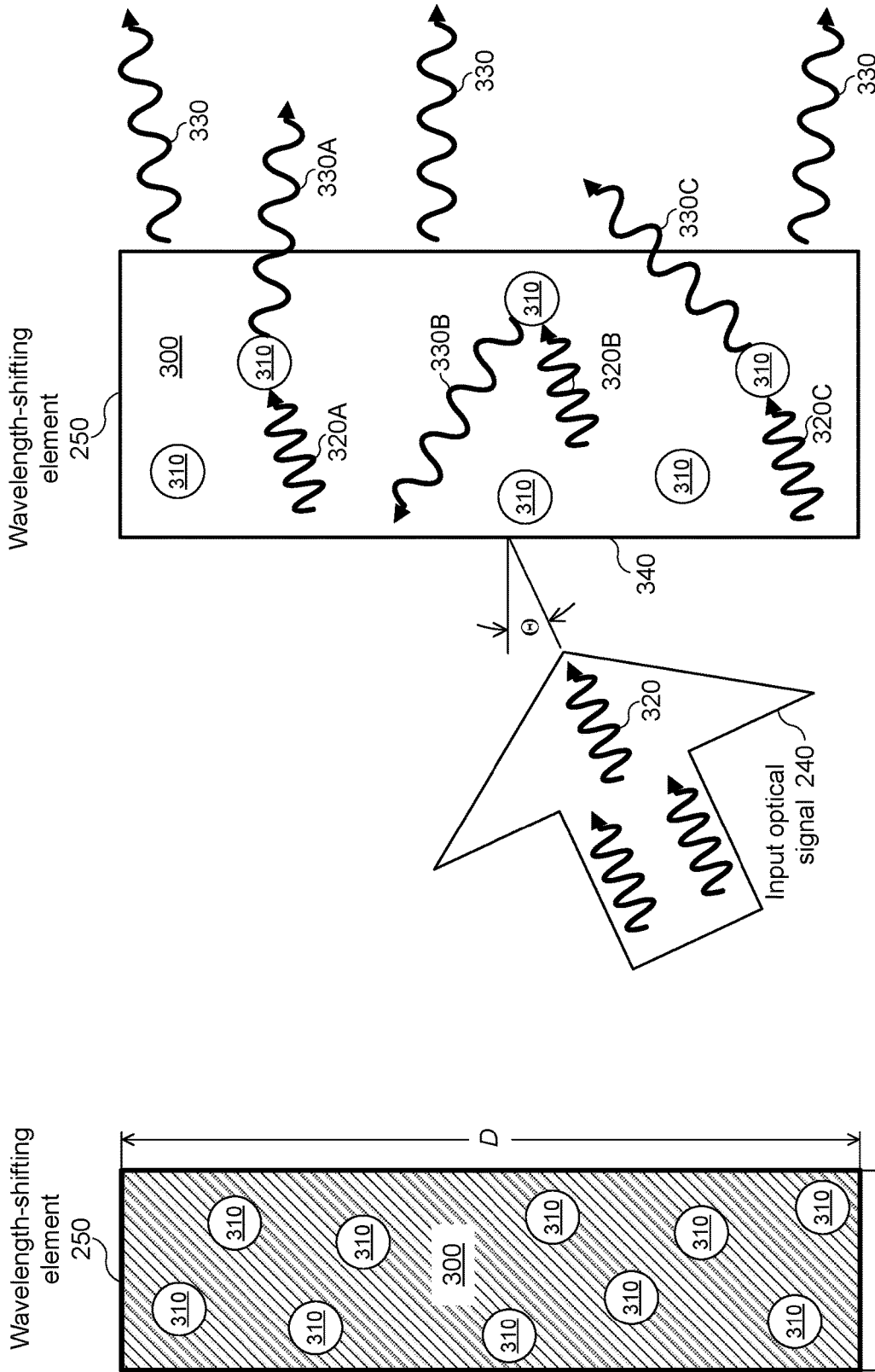

FIG. 3

FIG. 4

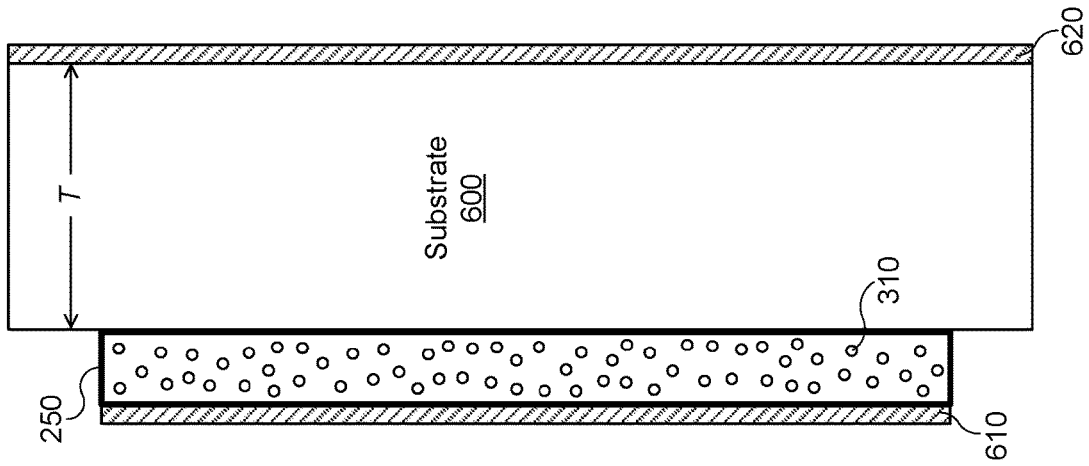

FIG. 6

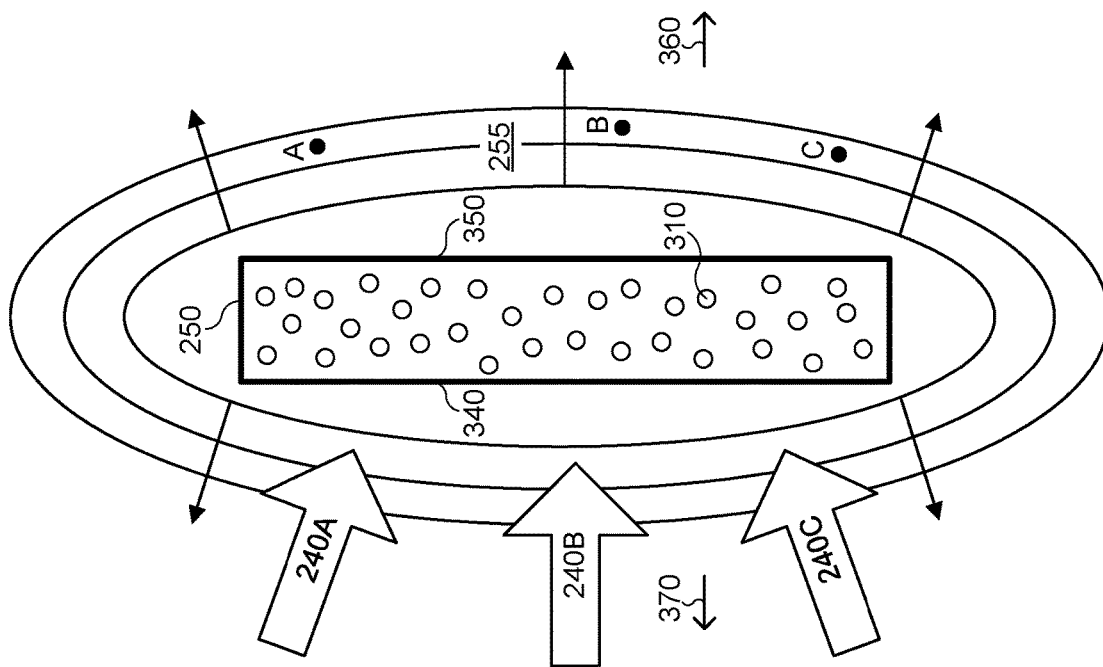

FIG. 5

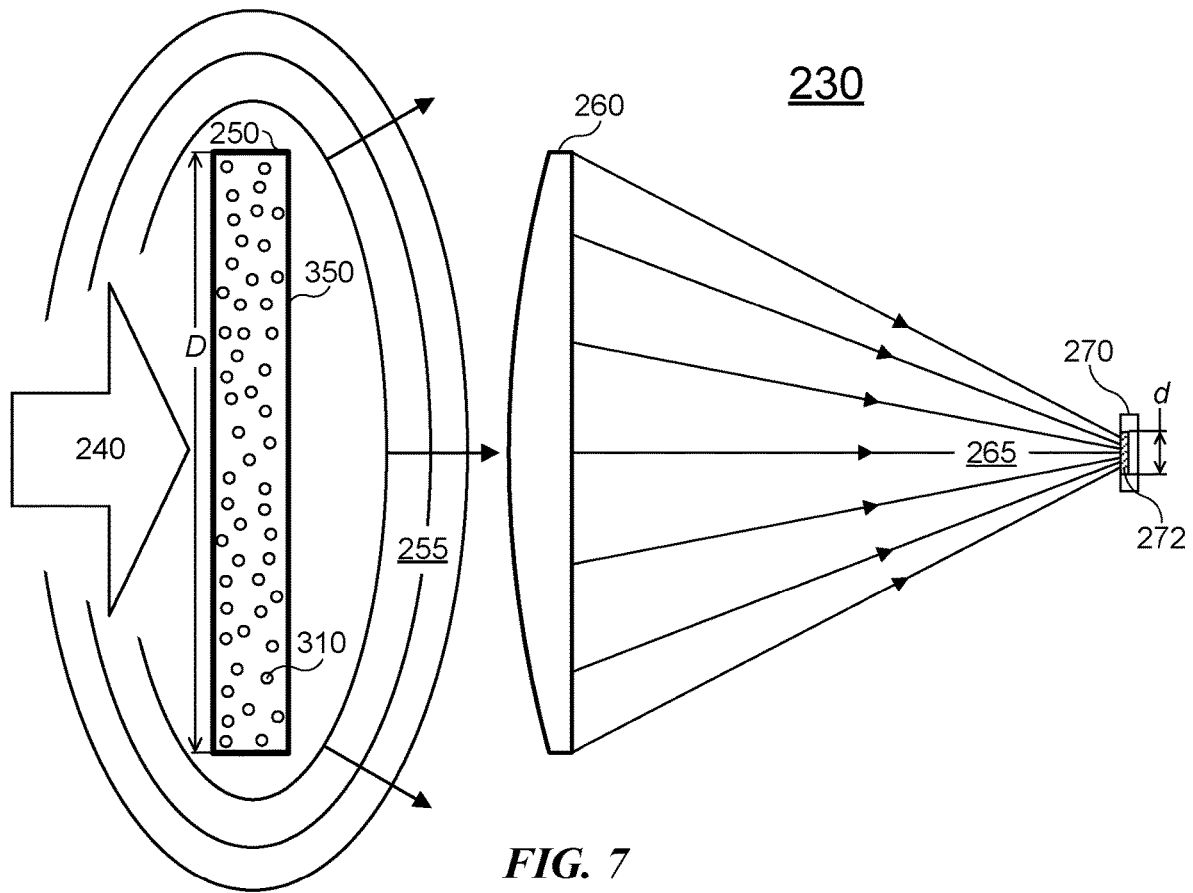

FIG. 7

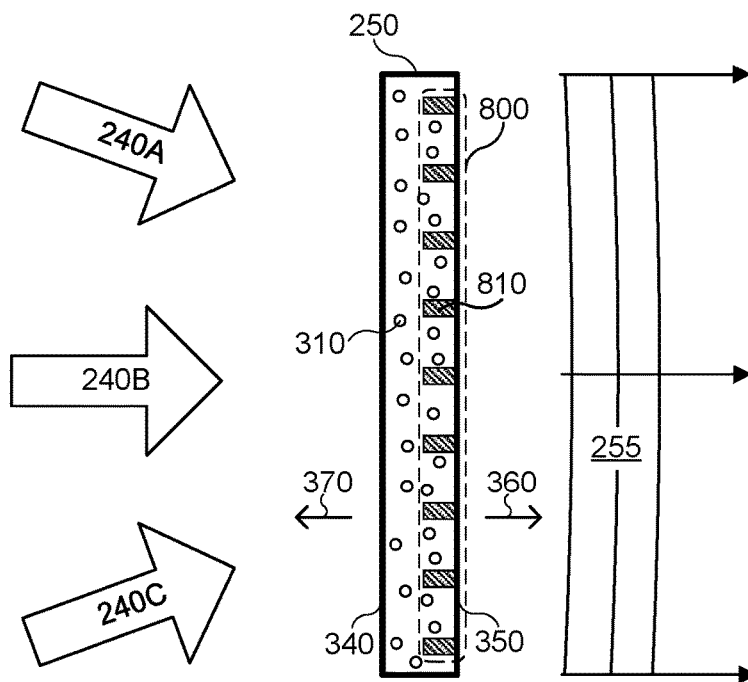

FIG. 8

230

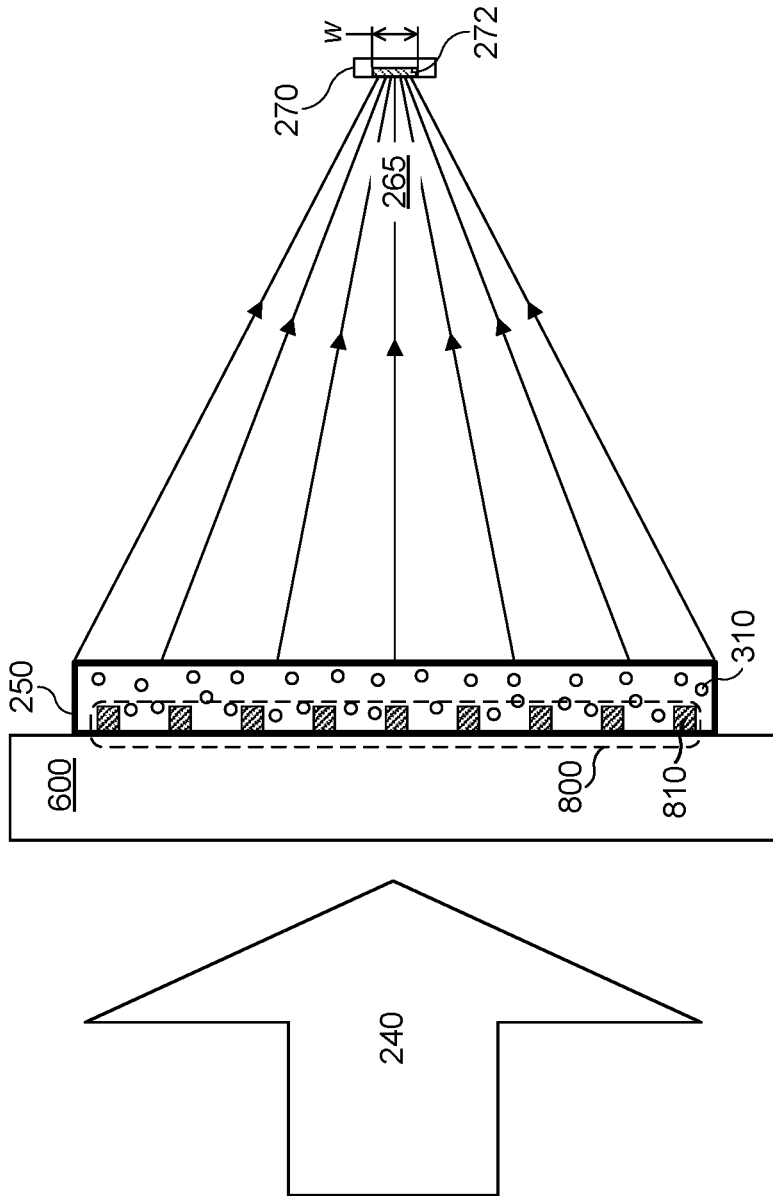

FIG. 9

1000

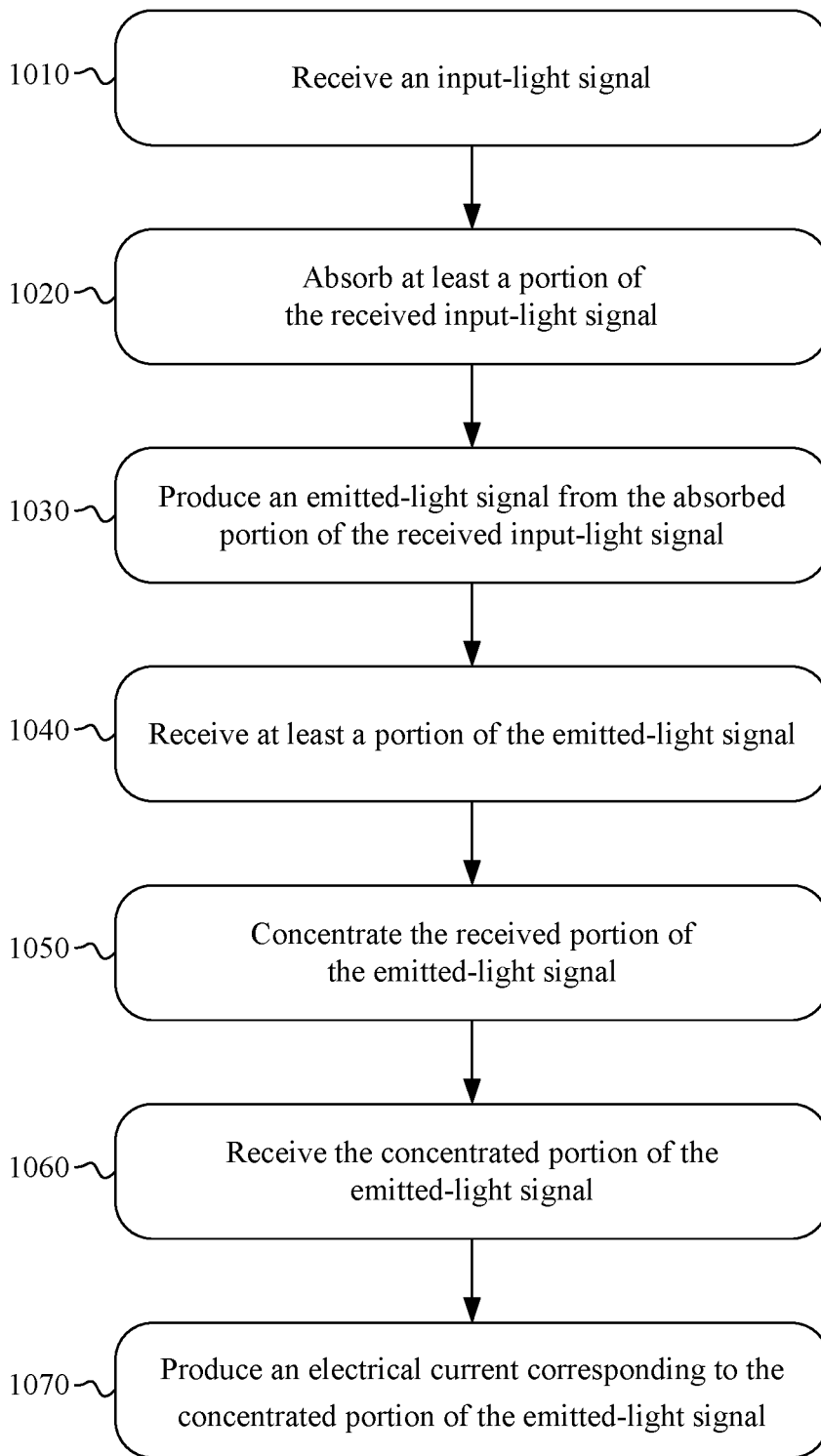

FIG. 10

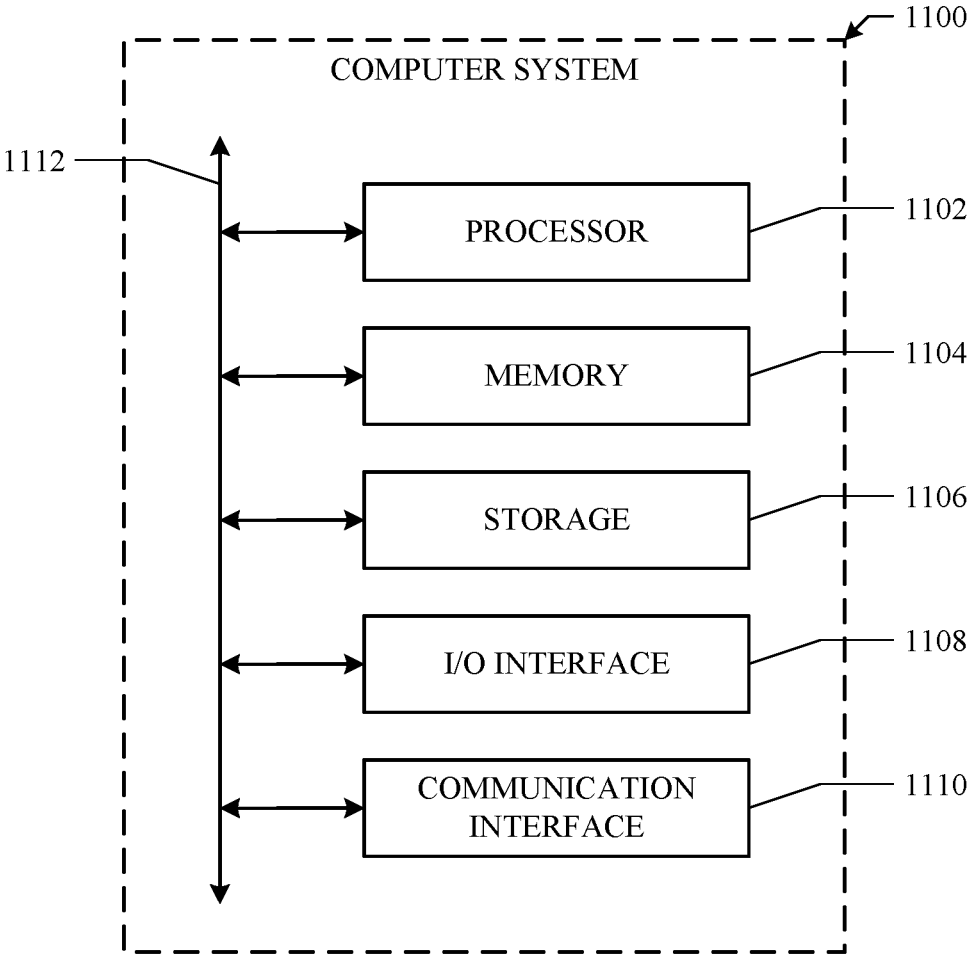

FIG. 11

LUMINESCENT DETECTOR FOR FREE-SPACE OPTICAL COMMUNICATION

PRIORITY

This application is a continuation under 35 U.S.C. § 120 of U.S. patent application Ser. No. 15/662,568, filed 28 Jul. 2017, which is a continuation under 35 U.S.C. § 120 of U.S. patent application Ser. No. 15/090,786, filed 5 Apr. 2016, now issued as U.S. Pat. No. 9,749,044 on 29 Aug. 2017, each of which is incorporated herein by reference.

TECHNICAL FIELD

This disclosure generally relates to free-space optical communication.

BACKGROUND

A communication system may include an optical-communication link where an optical transmitter and an optical receiver send or receive data using free-space optical communication. An optical-communication link may be a one-way link where one communication station transmits information to another communication station, or a communication link may be bidirectional where both communication stations transmit and receive information. An optical-communication link may have a data rate between 1 megabit per second and 100 gigabits per second. For example, a free-space optical-communication link may have a data rate of 10 gigabits per second. In a free-space optical-communication link, an optical transmitter and an optical receiver may be separated by relatively short distances (e.g., 1 m to 1 km) or moderate to long distances (e.g., 1 km to 36,000 km).

An optical transmitter and receiver may communicate using any suitable optical wavelength, such as for example, 405 nm, 780 nm, 1.3 μm , or 1.5 μm . An optical transmitter may transmit an optical signal by applying a current modulation to a laser diode or a light-emitting diode. An optical receiver may include a photodetector that converts received light from the transmitter into an electrical current. An optical receiver may also include a transimpedance amplifier that produces an output voltage signal based on the electrical current from the photodetector.

SUMMARY OF PARTICULAR EMBODIMENTS

In particular embodiments, a luminescent detector may be configured to receive an input optical signal, produce wavelength-shifted light from the input optical signal, and then produce an output electrical current from the wavelength-shifted light. The input optical signal may include high-speed data modulated onto the optical signal and sent from a transmitter located some distance away from the luminescent detector (e.g., located 1 m to 36,000 km away). In particular embodiments, a luminescent detector may include a wavelength-shifting element and a photodetector. Additionally, in particular embodiments, a luminescent detector may include a concentrating element (e.g., a lens or a nonimaging optical element). The wavelength-shifting element may include a wavelength-shifting material (e.g., a fluorescent dye or quantum dots) that absorbs the input optical signal and emits light at a longer wavelength through a fluorescence process. The emitted light may be radiated substantially equally in all directions, or the emitted light may be radiated in a directional manner. As an example and

not by way of limitation, the wavelength-shifting element may include a plasmonic or dielectric structure that causes the emitted light to be radiated in a directional manner primarily along the forward or backward directions. The luminescent detector may include a lens or a nonimaging optical element that receives the light radiated in the forward direction and concentrates the received light onto a photodetector. As another example and not by way of limitation, the wavelength-shifting element may include a plasmonic or dielectric structure that receives a portion of the emitted light and causes the received portion of emitted light to be concentrated as a converging beam directed onto a photodetector. The photodetector produces an electrical-current signal that corresponds to the high-speed data modulated onto the optical signal sent by the optical transmitter. The electrical-current signal may be sent to a transimpedance amplifier to produce an output-voltage signal which may be sent to other electronic devices for recovery and processing of the high-speed data.

In particular embodiments, the light emitted by the wavelength-shifting material may be substantially directional. As an example and not by way of limitation, even if the input optical signal received by the luminescent detector has a distorted, nonuniform, or time-varying distribution of incidence angles (which may be caused at least in part by atmospheric turbulence experienced as the optical signal propagates from the transmitter to the luminescent detector), the emitted light from the wavelength-shifting element may have a substantially directional character, hence a small numerical aperture. A luminescent detector may offer a relatively large effective detector area, a relatively fast response time, and a relatively large field of view. Therefore, a luminescent detector may be substantially insensitive to the incidence angle or phase fluctuations of the input optical signal. Since the light emitted by the wavelength-shifting material does not exhibit the large spread in propagation direction of the input optical signal, the emitted light may be concentrated to a small spot that is incident on a photodetector. Additionally, even though the distribution of incidence angles of the input light may vary in time due to atmospheric turbulence, the concentrated spot may remain incident on the photodetector, resulting in a significant reduction in amplitude fluctuations of the electrical-current signal produced by the photodetector. Moreover, the large effective detector area, the large field of view, and the relative insensitivity to incidence angle provided by a luminescent detector may allow the beam-pointing accuracy and tracking requirements for the optical transmitter to be relaxed.

The embodiments disclosed above are only examples, and the scope of this disclosure is not limited to them. Particular embodiments may include all, some, or none of the components, elements, features, functions, operations, or steps of the embodiments disclosed above. Embodiments according to the invention are in particular disclosed in the attached claims directed to a method, a storage medium, a system and a computer program product, wherein any feature mentioned in one claim category, e.g. method, can be claimed in another claim category, e.g. system, as well. The dependencies or references back in the attached claims are chosen for formal reasons only. However any subject matter resulting from a deliberate reference back to any previous claims (in particular multiple dependencies) can be claimed as well, so that any combination of claims and the features thereof are disclosed and can be claimed regardless of the dependencies chosen in the attached claims. The subject-matter which can be claimed comprises not only the combinations of features

as set out in the attached claims but also any other combination of features in the claims, wherein each feature mentioned in the claims can be combined with any other feature or combination of other features in the claims. Furthermore, any of the embodiments and features described or depicted herein can be claimed in a separate claim and/or in any combination with any embodiment or feature described or depicted herein or with any of the features of the attached claims.

BRIEF DESCRIPTION OF THE DRAWINGS

FIG. 1 illustrates an example network environment that includes a pair of Rx/Tx modules connected by a free-space optical link.

FIG. 2 illustrates a block diagram of an example optical receiver.

FIG. 3 illustrates an example wavelength-shifting element that includes a wavelength-shifting material.

FIG. 4 illustrates an example wavelength-shifting element with an input optical signal.

FIG. 5 illustrates an example wavelength-shifting element with input optical signals and an emitted optical signal.

FIG. 6 illustrates an example wavelength-shifting element affixed to an example substrate.

FIG. 7 illustrates an example luminescent detector.

FIG. 8 illustrates an example wavelength-shifting element that includes an example plasmonic or dielectric structure.

FIG. 9 illustrates an example luminescent detector that includes an example plasmonic or dielectric structure.

FIG. 10 illustrates an example method for detecting an optical signal using a luminescent detector.

FIG. 11 illustrates an example computer system.

DESCRIPTION OF EXAMPLE EMBODIMENTS

FIG. 1 illustrates an example network environment 100 that includes a pair of Rx/Tx modules (200A and 200B) connected by a free-space optical link 150A. In particular embodiments, Rx/Tx module 200A or 200B may be referred to as a receive/transmit module, a receiver/transmitter module, a receiver module, a transmitter module, or a transceiver module. As illustrated in FIG. 1, Rx/Tx module 200A includes optical transmitter 210, and Rx/Tx module 200B includes optical receiver 220. Link 150A may be a one-way free-space optical (FSO) link where transmitter 210 of Rx/Tx module 200A transmits data in the form of a modulated optical signal to receiver 220 of Rx/Tx module 200B. In particular embodiments, Rx/Tx module 200A may also include an optical receiver 220 (not illustrated in FIG. 1), and Rx/Tx module 200B may also include an optical transmitter 210 (not illustrated in FIG. 1). As an example and not by way of limitation, link 150A may be a bidirectional link where Rx/Tx modules 200A and 200B each include an optical transmitter 210 and an optical receiver 220. Modules 200A and 200B may each be configured to send and receive information using their respective transmitter 210 and receiver 220. In particular embodiments, link 150A may be referred to as a free-space optical link, a FSO link, an optical-communication link, a FSO communication link, an optical link, or a communication link.

In particular embodiments, a network environment 100 may provide wireless connectivity, through one or more links 150, to a network 110 or a client system 130. As an example and not by way of limitation, one or more links 150 may connect client system 130 to Rx/Tx module 200B, and one or more other links 150 may connect Rx/Tx module

200B to network 110. In the example of FIG. 1, client system 130 is connected to Rx/Tx module 200B by link 150B, which may be a wireline, wireless, or optical (e.g., fiber-optic or free-space) link. Rx/Tx module 200B is connected to Rx/Tx module 200A by free-space optical link 150A, which may be a one-way link with a data rate of 1 to 100 gigabits per second (Gbps) or a bidirectional link with a data rate of 1 to 100 gigabits per second (Gbps) in both directions. Additionally, Rx/Tx module 200A is connected to network 110 by link 150, which may be a wireline, wireless, or optical link 150. Although FIG. 1 illustrates a particular arrangement of client system 130, links 150, Rx/Tx modules 200, and network 110, this disclosure contemplates any suitable arrangement of client system 130, links 150, Rx/Tx modules 200, and network 110. Moreover, although FIG. 1 illustrates a particular number of client systems 130, links 150, Rx/Tx modules 200, and networks 110, this disclosure contemplates any suitable number of client systems 130, links 150, Rx/Tx modules 200, and networks 110. As an example and not by way of limitation, network environment 100 may include multiple client systems 130, links 150, Rx/Tx modules 200, and networks 110.

This disclosure contemplates any suitable network 110. As an example and not by way of limitation, one or more portions of network 110 may include an ad hoc network, an intranet, an extranet, a virtual private network (VPN), a local area network (LAN), a wireless LAN (WLAN), a wide area network (WAN), a wireless WAN (WWAN), a metropolitan area network (MAN), a portion of the Internet, a portion of the Public Switched Telephone Network (PSTN), a cellular telephone network, or a combination of two or more of these. Network 110 may include one or more networks 110.

This disclosure contemplates any suitable links 150. In particular embodiments, one or more links 150 include one or more wireline (such as for example Digital Subscriber Line (DSL) or Data Over Cable Service Interface Specification (DOCSIS)), wireless (such as for example RF, Wi-Fi, or Worldwide Interoperability for Microwave Access (WiMAX)), or optical (such as for example free-space optical, Gigabit Ethernet (e.g., 10 Gigabit Ethernet) over optical fiber, Synchronous Optical Network (SONET), or Synchronous Digital Hierarchy (SDH)) links. In particular embodiments, one or more links 150 each include an ad hoc network, an intranet, an extranet, a VPN, a LAN, a WLAN, a WAN, a WWAN, a MAN, a portion of the Internet, a portion of the PSTN, a cellular technology-based network, a satellite communications technology-based network, another link 150, or a combination of two or more such links 150. Links 150 need not necessarily be the same throughout network environment 100. One or more first links 150 may differ in one or more respects from one or more second links 150.

In particular embodiments, a free-space optical (FSO) link 150 or a wireless link 150 may refer to any suitable electromagnetic-radiation-based communication signal transmitted through free space. As an example and not by way of limitation, a FSO link 150 may be a free-space optical link (e.g., link 150A in FIG. 1) that uses light for sending or receiving data. A FSO link 150 may use light having any suitable wavelength, such as for example, near-ultraviolet light (e.g., light with a wavelength between approximately 100 nm and 400 nm), visible light (e.g., light with a wavelength between approximately 400 nm and 750 nm), or near-infrared light (e.g., light with a wavelength between approximately 750 nm and 2.5 μm). As another example and not by way of limitation, a wireless link 150 may use radio-frequency (RF) signals for communication

(e.g., link **150B** in FIG. 1). A wireless RF link **150** may operate at any suitable frequency from approximately 300 kHz to approximately 300 GHz. In particular embodiments, the unit of length “ μm ” may be referred to as a micrometer or a micron (e.g., $1\ \mu\text{m}$ equals 10^{-6} meters). Although this disclosure describes and illustrates particular FSO or wireless links having particular wavelengths or frequencies, this disclosure contemplates any suitable FSO or wireless links having any suitable wavelengths or frequencies.

In particular embodiments, two Rx/Tx modules (e.g., Rx/Tx modules **200A** and **200B** in FIG. 1) may be directly connected to one another by a point-to-point wireless communications link **150**. In particular embodiments, a point-to-point link **150** may refer to a communications link **150** that directly and exclusively connects two Rx/Tx modules to one another. In particular embodiments, a point-to-point communications link **150** may be a one-way link **150** (e.g., information or signals are sent in one direction from a transmitter **210** to a receiver **220**) or a bidirectional link **150** (e.g., data is sent in both directions between two Rx/Tx modules). As an example and not by way of limitation, a bidirectional point-to-point link **150** between two Rx/Tx modules (e.g., Rx/Tx modules **200A** and **200B** in FIG. 1) may provide a data rate of 1-100 Gbps in each direction. In particular embodiments one or more Rx/Tx modules may be connected to one or more other Rx/Tx modules by a multipoint link **150**. As an example and not by way of limitation, one transmitter **210** may broadcast an optical signal that may be received by two or more receivers **220**. As another example and not by way of limitation, one receiver **220** may receive two or more optical signals sent by two or more respective transmitters **210**.

In particular embodiments, a user **101** may access network **110** on a client system **130** through one or more links **150**. As illustrated in FIG. 1, client system **130** may connect to network **110** via links **150**, **150A**, and **150B**. In particular embodiments, user **101** may be an individual (human user), an entity (e.g., an enterprise, business, or third-party application), or a group (e.g., of individuals or entities) that interacts or communicates, at least in part, by a link **150** provided by a Rx/Tx module **200A** or **200B**. Client system **130** may be any suitable computing device, such as, for example, a personal computer, a laptop computer, a cellular telephone, a smartphone, a tablet computer, or an augmented/virtual reality device. This disclosure contemplates any suitable client systems **130**. A client system **130** may enable a network user at client system **130** to access network **110**. A client system **130** may enable its user **101** to communicate with other users at other client systems **130**. Although this disclosure describes and illustrates particular client systems accessing particular networks via particular links, this disclosure contemplates any suitable client systems accessing any suitable networks via any suitable links.

In particular embodiments, an Rx/Tx module **200** may be located on the ground (e.g., in a ground-based communication station) or may be airborne (e.g., in an unmanned aerial vehicle). As an example and not by way of limitation, transmitter **210** and receiver **220** may each be located within the same room or building and may be located approximately 1 to 50 meters apart (e.g., separation distance illustrated in FIG. 1 may be 1-50 meters). As another example and not by way of limitation, transmitter **210** and receiver **220** may be used for building-to-building communication and may be located approximately 50 meters to 1 km apart. As another example and not by way of limitation, transmitter **210** and receiver **220** may each be part of a ground-based communication station, and the two ground-based commu-

nication stations may have a separation distance of approximately 1 km to 100 km. As another example and not by way of limitation, transmitter **210** may be part of a ground-based communication station, and receiver **220** may be located in an unmanned aerial vehicle (UAV). The UAV (which may be referred to as a drone, remotely piloted aircraft, or autonomous aircraft) may be configured to fly at a cruising altitude within a range of approximately 3,000 feet to approximately 100,000 feet above sea level. The UAV may be connected to the Internet via optical link **150A**, and the UAV may provide wireless connectivity to the Internet for one or more client systems **130** located in a terrestrial area below the UAV. As another example and not by way of limitation, receiver **220** may be located in a satellite operating in a low Earth orbit (LEO), medium Earth orbit (MEO), or a geostationary orbit (GEO). For example, receiver **220** may be located in a GEO satellite with an altitude of approximately 35,800 km above mean sea level. Although this disclosure describes and illustrates particular transmitters and receivers having particular locations and particular separation distances, this disclosure contemplates any suitable transmitters and receivers having any suitable locations and any suitable separation distances.

In particular embodiments, transmitter **210** and receiver **220** may each be stationary or moving. As an example and not by way of limitation, transmitter **210** and receiver **220** may each be stationary (e.g., located on or attached to a stationary object, such as for example, a table, floor, wall, ceiling, building, or tower) where the location or orientation of the transmitter **210** does not change significantly with respect to the receiver **220**. In particular embodiments, transmitter **210** may be stationary, and receiver **220** may be moving with respect to the transmitter **210**. As an example and not by way of limitation, transmitter **210** may be located in a non-moving ground station, and receiver **220** may be located in a UAV flying along a flight path at an altitude of approximately 60,000 to 70,000 feet above the transmitter **210**. As another example and not by way of limitation, receiver **220** may be coupled to a head-mounted display (HMD) for an augmented/virtual reality device. A user **101** wearing the HMD may be able to move with respect to a transmitter **210** that sends an optical signal to the receiver **220**. In particular embodiments, receiver **220** may be part of client system **130**. As an example and not by way of limitation, client system **130** may be an augmented/virtual reality device (e.g., an HMD worn by user **101**) with receiver **220** integrated into the augmented/virtual reality device, and link **150B** may include one or more wires, printed-circuit-board traces, or coaxial cables connecting receiver **220** to a chip within client system **130** that performs data recovery.

In particular embodiments, a FSO link **150** between a transmitter **210** and a receiver **220** may be a one-way link or a bidirectional link and may have any suitable data rate. As an example and not by way of limitation, FSO link **150A** illustrated in FIG. 1 may have a data rate of approximately 1 megabit per second (Mbps) to 100 gigabits per second (Gbps). As another example and not by way of limitation, link **150A** may be a one-way link with a data rate of 1 Gbps, 2.4 Gbps, or 10 Gbps. As another example and not by way of limitation, link **150A** may be a bidirectional link with a data rate of 32 Gbps in each direction. In particular embodiments, a bidirectional link **150** may be an asymmetric link (e.g., a bidirectional link having different data rates in each direction) or a hybrid link (e.g., a bidirectional link using different communication formats in each direction). As an example and not by way of limitation, an asymmetric link

150 between a HMD and a console (e.g., a computer that broadcasts high-definition video content to the HMD) may have a relatively high data rate (e.g., 1 Gbps or higher) for the console-to-HMD portion of the link and a lower data rate (e.g., approximately 1 Mbps) for the HMD-to-console portion of the link. As another example and not by way of limitation, a hybrid link 150 between a HMD and a console may use a FSO communication technique for the console-to-HMD portion of the link and an RF wireless technique (e.g., Wi-Fi) for the HMD-to-console portion of the link. Although this disclosure describes and illustrates particular communication links having particular data rates and particular formats, this disclosure contemplates any suitable communication links having any suitable data rates and any suitable formats.

In particular embodiments, optical transmitter 210 (which may be referred to as a transmitter or a laser transmitter) may include various optical, opto-electronic, or electronic components, such as for example, a laser source, a light-emitting diode (LED), a lens, an aiming mechanism, or a mirror. As an example and not by way of limitation, a laser source in transmitter 210 may include an indium-gallium-nitride (InGaN) diode laser that produces light with a peak wavelength in the range of 400-410 nm, an aluminum-gallium-arsenide (AlGaAs) diode laser that produces light with a peak wavelength in the range of 780-830 nm, or an indium-gallium-arsenide-phosphide (InGaAsP) diode laser that produces light with a peak wavelength in the range of 1.3-1.6 μm . As another example and not by way of limitation, transmitter 210 may include an InGaN diode laser operating at approximately 405 nm with an average optical output power of approximately 0.1 to 100 mW. The InGaN diode laser may be current modulated to produce a modulated optical signal. As another example and not by way of limitation, transmitter 210 may include a continuous-wave (CW) diode laser coupled to an external amplitude modulator (e.g., a lithium-niobate amplitude modulator). As another example and not by way of limitation, transmitter 210 may include an LED that is current modulated to produce a modulated optical signal. In particular embodiments, transmitter 210 may include a lens for collimating or adjusting the optical beam emitted by a laser source. As an example and not by way of limitation, a lens may be positioned toward or away from the laser-source output to adjust the divergence angle, collimation, focusing, or size of the optical beam. In particular embodiments, transmitter 210 may include a pointing and tracking mechanism for adjusting the pointing or aiming of the optical beam. As an example and not by way of limitation, a mechanical tip-tilt assembly may be used to adjust the orientation of the transmitter 210 allowing the pointing of the emitted laser beam to be changed. As another example and not by way of limitation, the optical beam may be configured to reflect off a beam-steering mirror, and the orientation of the mirror may be adjusted to change the pointing of the optical beam. Although this disclosure describes and illustrates particular optical transmitters that include particular components, this disclosure contemplates any suitable optical transmitters that include any suitable components.

FIG. 2 illustrates a block diagram of an example optical receiver 220. In particular embodiments, optical receiver 220 may receive an input optical signal 240. As an example and not by way of limitation, input optical signal 240 may be a free-space optical-communication signal sent from an optical transmitter 210. In particular embodiments, an input optical signal 240 may be referred to as an input-light signal, input light, a light signal, an input-light beam, a light beam,

an optical signal, an input optical beam, an input beam, an input laser beam, a laser beam, or an optical beam. The input optical signal 240 may have any suitable power, intensity, or wavelength. In particular embodiments, the input optical signal 240 may have an optical intensity at optical receiver 220 of approximately 0.01 to 100 mW/cm². As an example and not by way of limitation, input optical signal 240 may have a peak wavelength of approximately 405 nm and an optical intensity of 10 to 100 $\mu\text{W}/\text{cm}^2$. As another example and not by way of limitation, input optical signal 240 may have a peak wavelength of 1.4-1.6 μm and an optical intensity of 10-100 mW/cm². In particular embodiments, the input optical signal 240 may include near-ultraviolet light, visible light, or near-infrared light. As an example and not by way of limitation, the input optical signal 240 may include light having a peak wavelength of approximately 405 nm, 635 nm, 780 nm, 1 μm , 1.1 μm , 1.3 μm , or 1.5 μm . In particular embodiments, the input optical signal 240 received by the optical receiver 220 may have any suitable beam size, such as for example a beam diameter of approximately 1 mm to 20 cm. Although this disclosure describes and illustrates particular optical beams having particular intensities and particular wavelengths, this disclosure contemplates any suitable optical beams having any suitable intensities and any suitable wavelengths.

In the example of FIG. 2, optical receiver 220 includes luminescent detector (LD) 230 and transimpedance amplifier (TIA) 280. In particular embodiments, luminescent detector 230 may be configured to receive input optical signal 240 and produce electrical current 275 based on the received optical signal 240. In FIG. 2, the TIA 280 receives electrical current 275 from LD 230 and performs a transimpedance amplification of the electrical-current signal 275. In particular embodiments, a transimpedance amplification may refer to an electrical amplification process where an input electrical current 275 is converted into an output voltage signal 285. In FIG. 2, TIA 280 produces an output voltage signal 285 that corresponds to the input electrical-current signal 275. A transimpedance amplification may be characterized in part by a transimpedance gain (G) which has units of volts per ampere (V/A). As an example and not by way of limitation, an output voltage signal V_{out} may be related to an input electrical-current signal I_{input} by the expression $V_{out} = G \times I_{input}$. In particular embodiments, TIA 280 may have a transimpedance gain of approximately 100 V/A to 10^4 V/A. As an example and not by way of limitation, TIA 280 may have a transimpedance gain of 800 V/A, and an electrical current 275 of 1 mA will result in an output voltage signal 285 of approximately 0.8 volts, based on the above expression (e.g., 800 V/A \times 1 mA = 0.8 V).

In particular embodiments, TIA 280 may be configured to reduce, remove, or filter out a direct-current (DC) or constant-offset portion from electrical current 275. As an example and not by way of limitation, TIA 280 may have an AC-coupled (or, alternating-current-coupled) configuration or may include a high-pass filter that reduces, removes, or filters out a DC portion from the electrical-current signal 275. Removing the DC-current component may reduce or eliminate the sensitivity of TIA 280 to effects associated with ambient background light (e.g., room light or sunlight). Although this disclosure describes and illustrates particular transimpedance amplifiers having particular transimpedance gain and particular configurations, this disclosure contemplates any suitable transimpedance amplifiers having any suitable transimpedance gain and any suitable configuration.

In particular embodiments, input optical signal 240 may include high-speed data modulated onto the optical signal

according to any suitable modulation scheme, such as for example, amplitude-shift keying (ASK) or wavelength-shift keying (WSK). As an example and not by way of limitation, optical signal **240** may include a 1-Gbps stream of on-off keyed (OOK) digital data produced at transmitter **210** by applying a current modulation to a laser diode. As another example and not by way of limitation, an orthogonal frequency division multiplexing (OFDM) scheme may be applied where the optical signal intensity **240** includes a superposition of sub-channels of independently modulated data. The sub-channels may be modulated using a quadrature amplitude modulation (QAM) scheme (e.g., 16-QAM, 32-QAM, 64-QAM, or 256-QAM) or a binary phase-shift keying (BPSK) scheme. As an example and not by way of limitation, approximately 100 sub-channels may be combined to produce an optical signal **240** with a data rate of 2-2.5 Gbps. In particular embodiments, the output voltage signal **285** from TIA **280** may be sent to a physical-layer chip which may perform data recovery using an analog-to-digital converter, a demodulator, or a forward-error-correction decoder.

In particular embodiments, a luminescent detector **230** may refer to an apparatus configured to receive an input-light signal **240**, produce wavelength-shifted light **255** from the input-light signal **240** using a luminescent material, and produce an output electrical current **275** from the wavelength-shifted light **255**. In particular embodiments, a luminescent detector **230** may be referred to as a luminescence-based detector, a photoluminescent detector, a photoluminescence-based detector, a fluorescent detector, or a fluorescence-based detector. In particular embodiments, luminescent detector **230** may include various optical, optoelectronic, or electronic components. In the example of FIG. 2, luminescent detector **230** includes a wavelength-shifting element **250**, a concentrating element **260**, and a detector **270**. Although this disclosure describes and illustrates particular luminescent detectors that include particular components, this disclosure contemplates any suitable luminescent detectors that include any suitable components. In particular embodiments, a receiver **220** or a luminescent detector **230** may include a wavelength-shifting material that acts as a waveguide to guide an optical signal to a detector as disclosed in U.S. patent application Ser. No. 14/822,677, entitled "Multidirectional Communication System" and filed 10 Aug. 2015, which is incorporated herein by reference as an example and not by way of limitation.

As illustrated in FIG. 2, wavelength-shifting element **250** may be configured to receive input optical signal **240**. In particular embodiments, wavelength-shifting element **250** may include a wavelength-shifting material configured to absorb at least a portion of the received optical signal **240** and produce wavelength-shifted light **255** from the absorbed portion of the optical signal **240**. In particular embodiments, the wavelength-shifted light **255** may be referred to as emitted light, an emitted-light signal, radiated light, a radiated-light signal, or an emitted-optical signal. In particular embodiments, concentrating element **260** may be configured to receive at least a portion of the wavelength-shifted light **255** and concentrate the received portion of the wavelength-shifted light **255** to produce concentrated light **265** (which may be referred to as focused light). In particular embodiments, concentrating element **260** may include a refractive optical component (e.g., a lens, such as for example, a plano-convex lens or a Fresnel lens, or a refractive compound parabolic concentrator or other refractive parabolic condensing optics) or a reflective optical component (e.g., a concave mirror, an off-axis parabolic mirror, or a reflective

compound parabolic concentrator or other reflective parabolic condensing optics). As an example and not by way of limitation, concentrating element **260** (which may be referred to as an optical-concentrating element or a focusing element) may include a lens that focuses the received wavelength-shifted light **255** onto detector **270**. In particular embodiments, concentrating element **260** may include an imaging optical element (e.g., a lens) or a nonimaging optical element, such as for example, a plasmonic structure or a dielectric structure as described herein. In particular embodiments, luminescent detector **230** may include wavelength-shifting element **250** and detector **270**, and luminescent detector **230** may not include a separate or discrete concentrating element **260**. As an example and not by way of limitation, wavelength-shifting element **250** and concentrating element **260** may be integrated into a single element that produces light that is wavelength shifted and emitted in a concentrated or converging manner. The wavelength-shifting element **250** may include a plasmonic or dielectric structure configured to produce concentrated light **265** that is directed onto photodetector **270**. In particular embodiments, detector **270** may be a photodetector that converts received light into an electrical current. As an example and not by way of limitation, photodetector **270** may be configured to receive concentrated light **265** from wavelength-shifting element **250** or concentrating element **260** and produce electrical current **275** corresponding to the received concentrated light **265**. As illustrated in FIG. 2, the output electrical-current signal **275** from LD **230** may be supplied to a transimpedance amplifier **280**.

FIG. 3 illustrates an example wavelength-shifting element **250** that includes a wavelength-shifting material **310**. In particular embodiments, wavelength-shifting material **310** may include fluorescent dye, quantum dots, lattice defects, atomic or molecular materials (e.g., in gas, liquid, or solid phase), or fluorophores. In particular embodiments, wavelength-shifting material **310** may include a fluorescent dye that absorbs input light **240** over a particular range of wavelengths and produces wavelength-shifted light **255** from the absorbed light. The wavelength-shifted light may have a range of wavelengths that is longer than or shorter than the wavelength range of the absorbed light. As an example and not by way of limitation, the fluorescent dye may absorb input light **240** from approximately 375 nm to 425 nm and emit wavelength-shifted light **255** over a wavelength range of approximately 475 nm to 525 nm. As another example and not by way of limitation, wavelength-shifting material **310** may absorb input light **240** over a wavelength range that includes visible or near-infrared light, and the emitted wavelength-shifted light may have a wavelength range that is longer than or shorter than the wavelength range of the absorbed input light **240**. In particular embodiments, wavelength-shifting material **310** may include quantum dots, which are nanoscale particles of semiconductor material having sizes of approximately 1 nm to 10 nm. As an example and not by way of limitation, wavelength-shifting material **310** may include cadmium selenide/cadmium sulfide (CdSe/CdS) quantum dots or lead selenide/lead sulfide (PbSe/PbS) quantum dots. Although this disclosure describes and illustrates particular wavelength-shifting materials that absorb and emit light at particular wavelengths, this disclosure contemplates any suitable wavelength-shifting materials that absorb and emit light at any suitable wavelengths.

In particular embodiments, wavelength-shifting element **250** may include an encapsulant material **300**, and the wavelength-shifting material **310** may be contained within

the encapsulant material **300**. In particular embodiments, encapsulant material **300** may include a polymer or plastic material, such as for example, poly(methyl methacrylate) (which may be referred to as PMMA or acrylic), an acrylate-based polymer, polycarbonate, cyclic olefin copolymer (COC), or polyethersulfone (PES). As an example and not by way of limitation, wavelength-shifting material **310** may be contained within, distributed throughout, or incorporated into an encapsulant material **300**. In particular embodiments, wavelength-shifting element **250** may be formed by combining a wavelength-shifting material **310** with an encapsulant material **300**. As an example and not by way of limitation, a polymer material (e.g., PMMA) may be dissolved in an organic solvent (e.g., toluene, acetone, or methoxybenzene) to form a liquid, and a fluorescent dye may be mixed into the liquid. The polymer-solvent-dye mixture may then be spin-coated onto a substrate material (e.g., a transparent glass or plastic substrate), and after the solvent evaporates, a solid structure (e.g., wavelength-shifting element **250**) may be formed where the fluorescent dye is encapsulated within the solid PMMA encapsulant **300**. In particular embodiments, wavelength-shifting element **250** may be rigid (e.g., resistant to flexing by an applied force) or may be flexible. In particular embodiments, wavelength-shifting element **250** may be flat or may have a curved shape.

In particular embodiments, encapsulant material **300** may be substantially transparent. As an example and not by way of limitation, encapsulant material **300** alone (e.g., without wavelength-shifting material **310** present) may be substantially transparent to input optical light **240** or wavelength-shifted light **255**. In particular embodiments, encapsulant material **300** (without wavelength-shifting material **310** present) being substantially transparent may refer to an encapsulant material **300** with thickness t having an optical transmission for optical signal **240** or wavelength-shifted light **255** of greater than or equal to 80%, 90%, or 95%. Although this disclosure describes and illustrates particular encapsulant materials having particular properties and being made from particular materials, this disclosure contemplates any suitable encapsulant materials having any suitable properties and being made from any suitable materials.

In particular embodiments, wavelength-shifting element **250** may have a thickness t of approximately $0.05\ \mu\text{m}$ to approximately $1\ \text{mm}$. As an example and not by way of limitation, wavelength-shifting element **250** may have a thickness t of approximately $0.5\ \mu\text{m}$. In particular embodiments, wavelength-shifting element **250** may have a cross-sectional dimension D corresponding to a length, width, or diameter of a front or back surface of wavelength-shifting element **250**. In the example of FIG. 3, wavelength-shifting element **250** is illustrated in a side view, and the front or back surface of wavelength-shifting element **250** may have a circular, elliptical, square, or rectangular shape with a particular length, width, or diameter. As an example and not by way of limitation, wavelength-shifting element **250** may have a substantially circular cross-sectional shape with a diameter D or a substantially square cross-sectional shape with dimensions $D \times D$. In particular embodiments, dimension D of wavelength-shifting element **250** may be greater than or equal to $0.1\ \text{mm}$. As an example and not by way of limitation, dimension D may be approximately $0.1\ \text{mm}$ to $20\ \text{cm}$. As another example and not by way of limitation, wavelength-shifting element **250** may have a substantially circular shape with a diameter D of approximately $5\ \text{cm}$ and a thickness t of approximately $10\ \mu\text{m}$. In particular embodiments, dimension D may correspond to an input aperture of wavelength-shifting element **250**. The input aperture of

wavelength-shifting element **250** may represent an opening of wavelength-shifting element **250** or luminescent detector **230** through which input light **240** is received. As an example and not by way of limitation, dimension D may be $10\ \text{cm}$, and wavelength-shifting element **250** may be referred to as having a circular input aperture with a diameter of $10\ \text{cm}$. As another example and not by way of limitation, dimension D may be approximately $0.1\ \text{mm}$ to $30\ \text{cm}$, and input aperture of wavelength-shifting element **250** may have a corresponding area of approximately $0.01\ \text{mm}^2$ to $1\ \text{m}^2$. Although this disclosure describes and illustrates particular wavelength-shifting elements having particular thicknesses and particular cross-sectional dimensions, this disclosure contemplates any suitable wavelength-shifting elements having any suitable thicknesses and any suitable cross-sectional dimensions.

FIG. 4 illustrates an example wavelength-shifting element **250** with an input optical signal **240**. As discussed above, input optical signal **240** may be a free-space optical-communication signal (e.g., light from a modulated laser diode) sent from an optical transmitter **210**. As illustrated in FIG. 4, input optical signal **240** may be made up of a collection of input photons **320**. Similarly, the wavelength-shifted light **255** may be made up of photons **330** that are emitted by wavelength-shifting material **310**. In particular embodiments, an input photon **320** may be absorbed by a particle of wavelength-shifting material **310**, and the wavelength-shifting material **310** may then emit a photon **330**. In particular embodiments, a process of absorbing an input photon **320** that results in the emission of another photon **330** as illustrated in the example of FIG. 4 may be referred to as luminescence, photoluminescence, or fluorescence. In FIG. 4, input photons **320A**, **320B**, and **320C** are each absorbed by a particle of wavelength-shifting material **310**, which then results in the emission of photons **330A**, **330B**, and **330C**, respectively. As an example and not by way of limitation, wavelength-shifting material **310** may be a fluorescent dye. A molecule of fluorescent dye may absorb an input photon **320** and transition from a ground state into an excited energy state. The dye molecule may relax through one or more non-radiative transitions into a lower energy state, and then the dye molecule may emit a photon **330** and relax back into its ground state.

In particular embodiments, the average time that a particle of wavelength-shifting material **310** remains in an excited state before emitting photon **330** may be referred to as an upper-state lifetime, excited-state lifetime, radiative lifetime, fluorescence lifetime, or decay time. In particular embodiments, the wavelength-shifted light **255** emitted by wavelength-shifting element **250** may exhibit a power or intensity that decays exponentially with time based on the upper-state lifetime T . As an example and not by way of limitation, if the wavelength-shifting element **250** is illuminated by a short pulse of light, the resulting wavelength-shifted light **255** may be emitted with an optical intensity I that varies with time as $I(t) = I_0 e^{-t/\tau}$, where I_0 represents an initial, peak intensity value at $t=0$. In particular embodiments, wavelength-shifting material **310** may have an upper-state lifetime (τ) of less than or equal to 10 nanoseconds. As an example and not by way of limitation, the wavelength-shifting material **310** may be a fluorescent dye with an upper-state lifetime of approximately 1.5 nanoseconds. As another example and not by way of limitation, the wavelength-shifting material **310** may have an upper-state lifetime of approximately 10 - 100 picoseconds. In particular embodiments, the upper-state lifetime of wavelength-shifting material **310** may be reduced by application of the

Purcell effect, which relates to changing the upper-state lifetime of a fluorescent material by a modifying the material's environment. As an example and not by way of limitation, wavelength-shifting material **310** may be combined with another material (e.g., encapsulant material **300**) or with a structure (e.g., a resonant optical cavity or a plasmonic material) to result in a reduced upper-state lifetime. As another example and not by way of limitation, a wavelength-shifting material **310** with a 1-2 nanosecond upper-state lifetime may have its upper-state lifetime reduced to 10-100 picoseconds by including a material or structure in the wavelength-shifting element **250** that reduces the upper-state lifetime through the Purcell effect. In particular embodiments, the upper-state lifetime of wavelength-shifting material **310** may be reduced by incorporating the wavelength-shifting material **310** into encapsulant **300**. As an example and not by way of limitation, the upper-state lifetime of the wavelength-shifting material **310** may be reduced due to an interaction with or due to properties of the surrounding encapsulant material **300**. In particular embodiments, the quantum efficiency of wavelength-shifting material **310** may be increased due to an interaction with or due to properties of the surrounding encapsulant material **300**. As an example and not by way of limitation, the optical absorption of the wavelength-shifting material **310** may be increased due to an interaction with or due to properties of the surrounding encapsulant material **300**. Although this disclosure describes and illustrates particular wavelength-shifting materials having particular upper-state lifetimes, this disclosure contemplates any suitable wavelength-shifting materials having any suitable upper-state lifetimes.

In particular embodiments, an emitted photon **330** may have less energy or a longer wavelength than an input photon **320**. As an example and not by way of limitation, the absorbed photons **320** may have a wavelength range that includes visible or near-infrared light, and the emitted photons **330** may have a wavelength range that is longer than the wavelength range of the absorbed photons **320**. As another example and not by way of limitation, the absorbed photons **320** may have wavelengths of approximately 390-420 nm, and the emitted photons **330** may have wavelengths of approximately 470-530 nm. As another example and not by way of limitation, the absorbed photons **320** may have a peak absorption wavelength around 405 nm, and the emitted photons **330** may have a peak emission wavelength around 490 nm. As another example and not by way of limitation, the absorbed photons **320** may have wavelengths of approximately 700-750 nm, and the emitted photons **330** may have wavelengths of approximately 760-800 nm. As another example and not by way of limitation, the absorbed photons **320** may have wavelengths of approximately 1.4-1.5 μm , and the emitted photons **330** may have wavelengths of approximately 1.5-1.6 μm . In particular embodiments, an emitted photon **330** may have more energy or a shorter wavelength than an input photon **320**. As an example and not by way of limitation, the absorbed photons **320** may have a wavelength range that includes visible or near-infrared light, and the emitted photons **330** may have a wavelength range that is shorter than the wavelength range of the absorbed photons **320**. Although this disclosure describes and illustrates particular absorbed and emitted photons having particular wavelengths, this disclosure contemplates any suitable absorbed and emitted photons having any suitable wavelengths.

In particular embodiments, the wavelength-shifting material **310** of wavelength-shifting element **250** may absorb

greater than or equal to 70% of input optical signal **240**. As an example and not by way of limitation, wavelength-shifting element **250** may absorb greater than 80%, 90%, or 98% of input optical signal **240**. As another example and not by way of limitation, for every 100 input photons **320** of input optical signal **240**, greater than or equal to 70 of the input photons **320** may be absorbed by wavelength-shifting material **310** of wavelength-shifting element **250**. As another example and not by way of limitation, wavelength-shifting element **250** may have an optical transmission of less than 2%, 10%, or 20% for light of input optical signal **240**. In particular embodiments, the optical absorption of wavelength-shifting element **250** for emitted photons **330** may be less than or equal to 20%. As an example and not by way of limitation, the absorption of wavelength-shifting element **250** for emitted photons **330** may be less than 10%, 5%, or 2%. In particular embodiments, wavelength-shifting element **250** may be substantially absorptive to photons **320** of input optical signal **240** and may be substantially transmissive to emitted photons **330**. As an example and not by way of limitation, wavelength-shifting element **250** may absorb greater than 80% of input optical signal **240** and may absorb less than 20% of emitted photons **330**. As another example and not by way of limitation, wavelength-shifting element **250** may have an optical absorption of $\geq 95\%$ for 375-425 nm light and an optical absorption of $\leq 10\%$ for 475-525 nm light. Although this disclosure describes and illustrates particular wavelength-shifting elements having particular absorptions at particular wavelengths, this disclosure contemplates any suitable wavelength-shifting elements having any suitable absorptions at any suitable wavelengths.

In the example of FIG. 4, input optical beam **240** has an angle of incidence Θ of approximately 25° with respect to the front surface **340** of wavelength-shifting element **250**. In particular embodiments, the angle of incidence Θ of input optical beam **240** may be any suitable angle. As an example and not by way of limitation, the input optical beam **240** may be incident on the wavelength-shifting element **250** at an angle Θ of 0° to approximately $\pm 45^\circ$, where a zero-degree incidence angle represents normal incidence with respect to the front surface **340** of wavelength-shifting element **250**. As another example and not by way of limitation, optical beam **240** may have an angle of incidence Θ with respect to the front surface **340** of wavelength-shifting element **250** within the range of $\pm 25^\circ$, $\pm 15^\circ$, $\pm 5^\circ$, or within any suitable angular range. In particular embodiments, the absorption of input optical signal **240** by wavelength-shifting element **250** may be substantially uniform regardless of the angle of incidence Θ . As an example and not by way of limitation, the absorption of wavelength-shifting element **250** may be approximately equal to 95% for input optical signal **240** having any angle of incidence Θ within a range of $\pm 25^\circ$. As another example and not by way of limitation, the absorption of input optical signal **240** by wavelength-shifting element **250** may vary by less than any suitable amount (e.g., less than 10%, 5%, 2%, or 1%) as the angle of incidence Θ is varied over a particular range (e.g., over $\pm 25^\circ$, $\pm 15^\circ$, or $\pm 5^\circ$). In particular embodiments, an angular range over which wavelength-shifting element **250** may receive and absorb light of input optical signal **240** may be referred to as a field of view (FOV). As an example and not by way of limitation, if the absorption of input optical signal **240** is substantially constant for angles of incidence Θ within a $\pm 25^\circ$ range, then wavelength-shifting element **250** or luminescent detector **230** may be referred to as having a ± 25 -degree FOV or a 50-degree FOV. Although this disclosure describes and illustrates particular optical beams having particular angles

of incidence, this disclosure contemplates any suitable optical beams having any suitable angles of incidence.

FIG. 5 illustrates an example wavelength-shifting element 250 with input optical signals 240A, 240B, and 240C and an emitted-optical signal 255. Each input optical signal 240A-240C may represent a different optical signal 240 with a particular angle of incidence Θ with respect to front surface 340. In the example of FIG. 5, input beams 240A, 240B, and 240C have angles of incidence Θ of approximately -20° , 0° , and $+20^\circ$, respectively. In particular embodiments, emitted-optical signal 255 may include photons 330 emitted by wavelength-shifting material 310. In particular embodiments, each particle of wavelength-shifting material 310 may be an isotropic emitter that emits photons 330 in any direction with equal probability. As an example and not by way of limitation, photons 330 may be emitted substantially evenly in all directions by wavelength-shifting material 310 resulting in a substantially isotropic or uniform emitted-optical signal 255. As another example and not by way of limitation, for a given input optical signal 240A, 240B, or 240C, the intensity of emitted-optical signal 255 along the front surface 340 or the back surface 350 of wavelength-shifting element 250 may vary by less than 10%. In particular embodiments, the emitted-optical signal 255 may be substantially insensitive to the angle of incidence Θ of input optical signal 240. As an example and not by way of limitation, for each input beam 240A, 240B, or 240C, the emitted-optical signal 255 may have substantially the same wavelength range and the same optical intensity. As another example and not by way of limitation, the intensity of emitted-optical signal 255 at each of points A, B, and C may vary by less than 10% as the angle of incidence Θ is varied from -20° to $+20^\circ$.

In particular embodiments, wavelength-shifting material 310 may be a non-isotropic emitter that preferentially radiates emitted-light signal 255 in a forward direction 360 or a backward direction 370. In FIG. 5, arrows 360 and 370 represent forward and backward directions, respectively. Forward direction 360 points away from wavelength-shifting element 250 and along the same direction as input beam 240B, and backward direction 370 points away from wavelength-shifting element 250 and opposite to input beam 240B. In particular embodiments, light emitted in the forward direction 360 may refer to light emitted within a particular angle of forward direction 360. As an example and not by way of limitation, light emitted in the forward direction 360 may include light emitted within $\pm 1^\circ$, $\pm 5^\circ$, $\pm 10^\circ$, $\pm 20^\circ$, or within any suitable angular range of forward direction 360. Similarly, light emitted in the backward direction 370 may include light emitted within $\pm 1^\circ$, $\pm 5^\circ$, $\pm 10^\circ$, $\pm 20^\circ$, or within any suitable angular range of backward direction 370.

In particular embodiments, a non-isotropically-emitting wavelength-shifting element 250 may produce emitted light 255 that is substantially directed along the forward direction 360 or the backward direction 370. As an example and not by way of limitation, wavelength-shifting material 310 may be configured to act as a directional emitter that emits light signal 255 mostly in the forward and backward directions 360 and 370. As another example and not by way of limitation, greater than or equal to 80% of emitted light 255 may be directed along the forward 360 or backward 370 direction, and less than 20% of emitted light 255 may be directed off to the sides of wavelength-shifting element 250. As another example and not by way of limitation, greater than or equal to 40% of emitted light 255 may be directed within $\pm 10^\circ$ of forward direction 360, and greater than or equal to

40% of emitted light 255 may be directed within $\pm 10^\circ$ of backward direction 370. The remaining less-than 20% portion of emitted light may be directed off to the sides of wavelength-shifting element 250 (e.g., directed at angles greater than 10° with respect to forward direction 360 or backward direction 370). In particular embodiments, wavelength-shifting element 250 may produce emitted light 255 substantially along forward direction 360 or backward direction 370 regardless of the angle of incidence Θ of input optical signal 240. As an example and not by way of limitation, emitted light 255 may be directed substantially along forward 360 or backward 370 direction as the angle of incidence Θ is varied from -20° to $+20^\circ$. Although this disclosure describes and illustrates particular wavelength-shifting elements that produce particular isotropic or particular non-isotropic emitted-light signals, this disclosure contemplates any suitable wavelength-shifting elements that produce any suitable isotropic or any suitable non-isotropic emitted-light signals.

In particular embodiments, front surface 340 or back surface 350 of wavelength-shifting element 250 may include a dielectric coating. In particular embodiments, a dielectric coating may refer to one or more thin-film layers of one or more dielectric materials (e.g., magnesium fluoride, silicon dioxide, tantalum pentoxide, zinc sulfide, or titanium dioxide) deposited on front surface 340 or back surface 350 by vacuum deposition (e.g., evaporation or sputtering). In particular embodiments, a dielectric coating may act as an anti-reflection (AR) coating that reduces the optical reflectivity or loss of a surface due to specular reflection. As an example and not by way of limitation, an AR-coating applied to front surface 340 may reduce the reflectivity of front surface 340 to input light 240A-240C from approximately 5% to less than 1%, 0.5%, or any suitable reflectivity. Similarly, an AR-coating applied to back surface 350 may reduce the reflectivity of back surface 350 to emitted light 255 from approximately 4% to less than 0.5%. A front-surface AR-coating may increase the amount of input light 240 that reaches wavelength-shifting material 310 by reducing the reflectivity of front surface 340. A back-surface AR-coating may increase the amount of emitted photons 330 that exit from wavelength-shifting element 250 by reducing the reflectivity of back surface 350. In particular embodiments, a dielectric coating may act as a high-reflection (HR) coating that increases the optical reflectivity of a surface. As an example and not by way of limitation, an HR-coating applied to front surface 340 may provide a reflectivity of $\geq 80\%$ to emitted light 255. A front-surface HR-coating may reflect some of the emitted photons 330 so that they are redirected along the forward direction 360. In particular embodiments, a dielectric coating may act as an AR-coating for one range of wavelengths and an HR-coating for another range of wavelengths. As an example and not by way of limitation, a dielectric coating applied to front surface 340 may act as an AR-coating for input light 240 and an HR-coating for emitted light 255. As another example and not by way of limitation, a dielectric coating applied to front surface 340 may have a reflectivity of $\leq 1\%$ from approximately 375 nm to 425 nm and a reflectivity of $\leq 90\%$ from approximately 475 nm to 525 nm. Although this disclosure describes and illustrates particular dielectric coatings having particular reflectivity at particular wavelengths, this disclosure contemplates any suitable dielectric coatings having any suitable reflectivity at any suitable wavelengths.

FIG. 6 illustrates an example wavelength-shifting element 250 affixed to an example substrate 600. In particular embodiments, substrate 600 may be a substantially trans-

parent material, such as for example glass (e.g., fused silica), plastic, or polymer (e.g., PMMA). As an example and not by way of limitation, substrate **600** may have an optical transmission for optical signal **240** or emitted light **255** of greater than or equal to 80%, 90%, or 95%. In particular embodiments, substrate **600** may have a thickness T of approximately 0.5 mm to 10 mm. As an example and not by way of limitation, substrate **600** may have a thickness T of approximately 1 mm. In particular embodiments, wavelength-shifting element **250** may be affixed to substrate **600** by spin-coating or by use of an adhesive or epoxy. As an example and not by way of limitation, a polymer-solvent-dye mixture may be spin-coated directly onto substrate **600** resulting in a wavelength-shifting element **250** which is attached to substrate **600**. Although this disclosure describes and illustrates particular substrates made from particular materials and having particular dimensions, this disclosure contemplates any suitable substrates made from any suitable materials and having any suitable dimensions.

In particular embodiments, an input light signal **240** may be incident on wavelength-shifting element **250** in FIG. **6** from the right or left. In particular embodiments, wavelength-shifting element **250** may include dielectric coating **610** that acts as an AR-coating, an HR-coating, or a combined AR/HR-coating. As an example and not by way of limitation, input light **240** may be incident on wavelength-shifting element **250** from the left, and dielectric coating **610** may act as an AR-coating for input light **240**. As another example and not by way of limitation, dielectric coating **610** may be a combined AR/HR-coating that acts as an AR-coating for input light **240** and an HR-coating for emitted light **255**. As another example and not by way of limitation, input light **240** may be incident on wavelength-shifting element **250** from the right (e.g., input light **240** may pass through substrate **600** first before encountering wavelength-shifting element **250**), and dielectric coating **610** may be an AR-coating for emitted light **255**. In particular embodiments, substrate **600** may include dielectric coating **620** that acts as an AR-coating, an HR-coating, or a combined AR/HR-coating. As an example and not by way of limitation, input light **240** may be incident on wavelength-shifting element **250** from the left, and dielectric coating **620** may act as an AR-coating for emitted light **255**. As another example and not by way of limitation, input light **240** may be incident on wavelength-shifting element **250** from the right, and dielectric coating **620** may be an AR-coating for input light **240**. As another example and not by way of limitation, dielectric coating **620** may be a combined AR/HR-coating that acts as an AR-coating for input light **240** and an HR-coating for emitted light **255**. Although this disclosure describes and illustrates particular dielectric coatings applied to particular surfaces, this disclosure contemplates any suitable dielectric coatings applied to any suitable surfaces.

FIG. **7** illustrates an example luminescent detector **230**. In particular embodiments, luminescent detector **230** may include wavelength-shifting element **250**, concentrating element **260**, and photodetector **270**. As illustrated in FIG. **7**, wavelength-shifting element **250** may be configured to receive input optical signal **240** and, through a fluorescence process, produce emitted-light signal **255**. A portion of emitted-light signal **255** may be received by concentrating element **260**, which produces concentrated light **265**, and the concentrated light **265** is directed or concentrated onto active region **272** of photodetector **270**.

In particular embodiments, concentrating element **260** may be a lens or a nonimaging optical element positioned

between wavelength-shifting element **250** and photodetector **270**. As an example and not by way of limitation, lens **260** may be a plano-convex lens (as illustrated in FIG. **7**), a Fresnel lens (e.g., a Fresnel lens may be incorporated into or attached to the back surface of wavelength-shifting element **250**), or any other suitable lens. In particular embodiments, lens **260** may include a dielectric coating on one or more of its surfaces. As an example and not by way of limitation, lens **260** may include AR-coatings on its input and output surfaces to provide reduced reflectivity for emitted light **255**. In particular embodiments, lens **260** may be positioned behind wavelength-shifting element **250** (e.g., opposite the side upon which input beam **240** is incident) and may be configured to capture at least a portion of the emitted light **255** that passes through back surface **350** of wavelength-shifting element **250**. In particular embodiments, lens **260** may be located any suitable distance from wavelength-shifting element. As an example and not by way of limitation, lens **260** may be in contact with or attached to back surface **350** of wavelength-shifting element **250** (e.g., lens **260** may be affixed with an optically clear adhesive to back surface **350**, or lens **260** may be a Fresnel lens integrated into back surface **350**). As another example and not by way of limitation, lens **260** may be located 0 mm to approximately 200 mm from back surface **350** of wavelength-shifting element **250**. In particular embodiments, concentrating element **260** may be combined with or integrated into wavelength-shifting element **250**. As an example and not by way of limitation, luminescent detector **230** may not include a separate or discrete concentrating element **260**. As another example and not by way of limitation, the concentrating element **260** may be incorporated into wavelength-shifting element **250**, and the concentrating of emitted light **255** may be performed by wavelength-shifting element **250** (e.g., by a plasmonic or dielectric structure contained within wavelength-shifting element **250**).

In particular embodiments, lens **260** may have any suitable diameter and any suitable focal length. As an example and not by way of limitation, lens **260** may have a diameter that is approximately the same size as dimension D of wavelength-shifting element **250**. As another example and not by way of limitation, lens **260** may have a focal length of approximately 25 mm to 250 mm. As another example and not by way of limitation, wavelength-shifting element **250** may have a dimension D of approximately 50 mm, and lens **260** may have a 50-mm diameter and a 50-mm focal length. In particular embodiments, photodetector **270** and lens **260** may be separated by a distance that is approximately equal to the focal length of lens **260**. As an example and not by way of limitation, lens **260** may have a 100-mm focal length, and the distance between lens **260** and photodetector **270** may be approximately 100 mm. Although this disclosure describes and illustrates particular types of lenses having particular positions, diameters, or focal lengths, this disclosure contemplates any suitable types of lenses having any suitable positions, diameters, or focal lengths.

In particular embodiments, photodetector **270** may receive concentrated light **265** from concentrating element **260** and produce an electrical current **275** corresponding to the received concentrated light **265**. As an example and not by way of limitation, if the concentrated light **265** received by photodetector **270** has a peak power of 1 mW, then the corresponding current **275** produced by photodetector **270** may have a peak amplitude of 0.8 mA (which corresponds to photodetector **270** having an optical responsivity of 0.8 A/W). In particular embodiments, photodetector **270** may be a photodiode, such as for example, a semiconductor diode

structure that converts received light **265** into an electrical current **275**. As an example and not by way of limitation, photodetector **270** may be a silicon photodiode, germanium photodiode, indium-gallium-arsenide photodiode, or mercury-cadmium-telluride photodiode. As another example and not by way of limitation, photodetector **270** may be a photodiode with an optical responsivity of 0.1 to 1 amperes per watt (A/W) of incident optical power. As another example and not by way of limitation, photodetector **270** may be a photodiode with an active region **272** having a width d or a diameter d of less than or equal to 1 mm (e.g., active region **272** may have a diameter d of 100 μm). The active region **272** may refer to an area of photodetector **270** that is sensitive to light (e.g., the active region **272** converts input light into electrical current). As another example and not by way of limitation, photodetector **270** may be a photodiode with an active region **272** having an area of less than or equal to 1 mm^2 (e.g., active region **272** may have an area of 0.1 mm^2). As another example and not by way of limitation, photodetector **270** may be an avalanche photodiode (APD) that produces electrons from received light and then provides gain through avalanche multiplication. Although this disclosure describes and illustrates particular photodetectors having particular active regions with particular dimensions, this disclosure contemplates any suitable photodetectors having any suitable active regions with any suitable dimensions.

In particular embodiments, photodetector **270** may be a photodiode with a response time (e.g., a rise time or a fall time) that is approximately equal to or faster than the upper-state lifetime τ of wavelength-shifting material **310**. As an example and not by way of limitation, photodetector **270** may have a rise time of less than or equal to 2 nanoseconds. As another example and not by way of limitation, photodetector **270** may have a rise time of less than or equal to 100 picoseconds. In particular embodiments, luminescent detector **230** may have an input aperture with an area A_{LD} , (e.g., A_{LD} may correspond to the input aperture of wavelength-shifting element **250**), and photodetector **270** may have an active region **272** with an area A_{PD} . As an example and not by way of limitation, A_{LD} may be approximately 1 cm^2 to 400 cm^2 , and A_{PD} may be approximately 0.0001 mm^2 to 1 mm^2 . As another example and not by way of limitation, input aperture may have a diameter D greater than or equal to 1 cm, and photodetector active region **272** may have a diameter d less than or equal to 1 mm. As another example and not by way of limitation, input aperture may have a diameter D greater than or equal to 1 mm, and photodetector active region **272** may have a diameter d less than or equal to 20 μm . In particular embodiments, the ratio A_{LD}/A_{PD} may be referred to as an active-region gain and may represent an effective increase in the area of the active region of photodetector **270** provided by the structure of luminescent detector **230**. As an example and not by way of limitation, for a luminescent detector **230** having an input aperture with diameter $D=50$ mm and a photodetector active region **272** with a diameter $d=1$ mm, the active-region gain is $D^2/d^2=2500$. This provides a luminescent detector **230** having an effective area that is 2500 times larger than the area of active region **272** without significantly sacrificing the speed of the photodetector **270**. In particular embodiments, the optical power loss (e.g., due to atmospheric effects, such as for example, atmospheric absorption and turbulence) between a transmitter **210** and a receiver **220** may be approximately 30-60 dB. As an example and not by way of limitation, for a transmitter **210** that produces an average optical output power of 100 mW, a 50-dB optical loss

between the transmitter **210** and receiver **220** may result in approximately 1 μW of received optical power at receiver **220** (e.g., the received power is reduced by 50 dB, or a factor of 10^{-5}). In particular embodiments, by boosting the amount of light captured by receiver **220**, a receiver **220** with an active-region gain of A_{LD}/A_{PD} may result in an effective A_{LD}/A_{PD} reduction in the transmitter-to-receiver optical loss. As an example and not by way of limitation, for a 50-dB optical loss between transmitter **210** and receiver **220**, an active-region gain of 1000 \times may reduce the optical loss by 30 dB, resulting in an effective optical loss between transmitter **210** and receiver **220** of 20 dB. In particular embodiments, a luminescent detector **230** may behave as a detector having an active region with an effective area A_{LD} and a speed (e.g., a rise time or fall time) based on the speed of photodetector **270**. Luminescent detector **230** may perform as a detector having a relatively large effective area A_{LD} while still maintaining the relatively fast response time provided by the relatively small photodetector **270**. Additionally, luminescent detector **230** may exhibit a fairly large field of view (e.g., $\text{FOV} \geq 50^\circ$), while a conventional detector with a comparable lens and photodetector (and with no wavelength-shifting element) may exhibit a fairly limited field of view (e.g., $\text{FOV} \leq 2^\circ$).

In particular embodiments, concentrating element **260** may capture a portion of emitted-light signal **255** produced by the wavelength-shifting material **310** of wavelength-shifting element **250**. In particular embodiments, concentrating element **260** may receive greater than or equal to 25% of the total emitted-light signal **255**. As an example and not by way of limitation, wavelength-shifting material **310** may be an isotropic emitter that emits photons **330** in all directions with equal probability, and concentrating element **260** may be configured to capture at least 25% of the emitted-light signal **255**. As another example and not by way of limitation, wavelength-shifting material **310** may be a non-isotropic emitter configured to radiate most of the emitted-light signal **255** in the forward direction (e.g., toward concentrating element **260**) or in the backward direction. In this case, concentrating element **260** may receive greater than or equal to 40% of the total emitted-light signal **255**.

In particular embodiments, input optical beam **240** may exhibit a distorted, nonuniform, or time-varying distribution of incidence angles (which may be referred to as having a distorted, nonuniform, or time-varying wavefront or phase front). In particular embodiments, input optical beam **240** may exhibit significant wavefront distortion resulting from atmospheric turbulence as optical beam **240** propagates from transmitter **210** to receiver **220**. Additionally, the wavefront distortion of input optical beam **240** may be time varying since atmospheric turbulence may be associated with irregular air motions that exhibit time-varying changes in speed and direction.

In particular embodiments, wavelength-shifting element **250** may reduce or eliminate problems associated with input light signal **240** having a distorted wavefront. As an example and not by way of limitation, the wavelength-shifting element **250** may absorb input photons **320** from the input light signal **240** regardless of the wavefront shape of input light signal **240** and with an optical efficiency that depends primarily on the material and structure of wavelength-shifting element **250** and on whether it includes a plasmonic or dielectric structure. The emitted photons **330** of emitted light **255** may have no fixed or definite phase relationship with input photons **320**. The emitted light **255** may have no time coherence over the area of the wavelength-shifting element **250** but may be highly directional depending on the

plasmonic or dielectric material included with the wavelength-shifting element **250**. Regardless of whether the input optical signal **240** has a distorted, nonuniform, or time-varying distribution of incidence angles, the emitted light **255** from the wavelength-shifting element **250** may have a substantially directional character. As an example and not by way of limitation, the wavelength-shifted light **255** may be emitted primarily in the forward or backward directions or may be emitted as concentrated light that converges on detector **270**.

In particular embodiments, a luminescent detector **230** as described herein may offer a relatively large effective detector area, a relatively fast response time, a relatively large FOV, and relative insensitivity to wavefront distortion or phase fluctuations of input optical signal **240**. As an example and not by way of limitation, luminescent detector **230** may have an input aperture with an area of greater than 25 cm², a response time of less than 1 nanosecond, and a FOV of greater than 25 degrees. Additionally, luminescent detector **230** may have the ability to receive and detect input light **240** in a manner that is substantially insensitive to the wavefront distortion, phase variation, or mode quality of the input light **240**.

Previous approaches to detecting a free-space optical communication signal may employ a receiver with a lens that focuses received light onto a photodetector. However, such conventional approaches may have difficulty effectively focusing received light onto a relatively small photodetector since the received light can exhibit significant wavefront distortion caused by atmospheric turbulence as the optical signal propagates from the transmitter to the receiver. A beam with significant wavefront distortion may be focused to a distorted or relatively large spot (e.g., the focused beam spot may be larger than the active region of the photodetector). Moreover, a conventional receiver may have a relatively narrow FOV, and since the wavefront distortion can vary with time, the coupling of the light onto the detector can similarly vary with time (e.g., time-varying distribution of incidence angles can cause the focused beam spot to move laterally with respect to the photodetector), resulting in undesirable amplitude fluctuations in the output electronic signal produced by a conventional receiver.

In particular embodiments, a luminescent detector **230** that includes a wavelength-shifting element **250** as described herein may mitigate the shortcomings of conventional receivers. Since emitted light **255** may exhibit highly directional output depending on the structure of wavelength-shifting element **250** and not on the wavefront of input light **240**, the emitted light **255** can be effectively concentrated to a small spot (e.g., by parabolic condensing optics **260**). Additionally, even though the distribution of incidence angles of the input light **240** may vary in time due to atmospheric turbulence, the concentrated light **265** may remain concentrated onto the active region **272** (without exhibiting significant lateral motion), resulting in significantly reduced amplitude fluctuations in electrical current **275**. Moreover, the large effective area, the large FOV, and the relative insensitivity to incidence angle provided by luminescent detector **230** may reduce the requirements for beam pointing accuracy and tracking for transmitter **210**. An active tracking system on the transmitter side may not be required or the performance requirements for a tracking system may be relaxed since luminescent detector **230** may tolerate some amount of movement or angular variation of optical beam **240**.

FIG. 8 illustrates an example wavelength-shifting element **250** that includes an example plasmonic or dielectric struc-

ture **800**. In particular embodiments, wavelength-shifting element **250** may include wavelength-shifting material **310** and a plasmonic structure **800** or a dielectric structure **800**. A plasmonic structure **800** may refer to a metallic microstructure in which plasma oscillations (or, plasmons) may be induced by electromagnetic radiation (e.g., by emitted light **255**). The emitted light **255** from wavelength-shifting material **310** may be coupled to plasmonic structure **800** resulting in the generation of plasmons in or on the surface of plasmonic structure **800**. In the example of FIG. 8, plasmonic structure **800** is represented schematically by an arrangement of plasmonic-structure elements **810** surrounded by a dashed line. In particular embodiments, plasmonic structure **800** (which may be referred to as a plasmonic grating **800**) may be a metallic microstructure that includes a periodic or non-periodic arrangement of any suitable number (e.g., 10² to 10¹²) of plasmonic-structure elements **810**, and each element **810** may have a dimension on the order of 10 nanometers to 1 μm. As an example and not by way of limitation, plasmonic structure **800** may include plasmonic-structure elements **810** with a 0.1-μm length or diameter, and the elements **810** may be located approximately 1 μm apart. In particular embodiments, plasmonic-structure elements **810** may have any suitable shape (e.g., substantially spherical, elliptical, or rectangular), and the elements **810** may be made from any suitable electrically conductive material (e.g., aluminum, copper, silver, or gold). In particular embodiments, wavelength-shifting element **250** may include wavelength-shifting material **310** and a dielectric structure **800**. As an example and not by way of limitation, wavelength-shifting element **250** may include a structure made up of dielectric material embedded or contained within wavelength-shifting element **250**. As another example and not by way of limitation, wavelength-shifting element **250** may include a dielectric grating **800** doped with wavelength-shifting material **310**.

In particular embodiments, plasmonic or dielectric structure **800** may be located within wavelength-shifting element **250** or may be located on the front surface **340** or back surface **350** of wavelength-shifting element **250**. In particular embodiments, plasmonic or dielectric structure **800** may be located within wavelength-shifting element **250** and between front surface **340** and back surface **350**. As illustrated in FIG. 8, plasmonic or dielectric structure **800** may be located within wavelength-shifting element **250** and adjacent to back surface **350**. In particular embodiments, each particle of wavelength-shifting material **310** may be located within approximately 1 μm of one or more plasmonic-structure elements **810** of plasmonic structure **800**, which may allow the emitted light **255** to interact with or couple to the plasmonic structure **800**. In particular embodiments, plasmonic or dielectric structure **800** may be deposited or stamped onto a surface of a substrate **600**, and then the wavelength-shifting element **250** may be fabricated on the same surface of substrate **600** (e.g., by spin-coating, as described above). Although this disclosure describes and illustrates particular wavelength-shifting elements having particular plasmonic or dielectric structures with particular dimensions, this disclosure contemplates any suitable wavelength-shifting elements having any suitable plasmonic or dielectric structures with any suitable dimensions.

In particular embodiments, wavelength-shifting element **250** may include a plasmonic or dielectric structure **800** that causes the emitted light **255** to be radiated from the wavelength-shifting element **250** in a directional manner. As an example and not by way of limitation, the plasmonic-structure elements **810** of plasmonic structure **800** may act

as tiny antennas that cause the emitted light 255 to be radiated primarily in the forward direction 360 or backward direction 370. The emitted light 255 radiated in the forward direction 360 and backward direction 370 may include greater than 80% of the total emitted-light signal 255. As another example and not by way of limitation, a wavelength-shifting element 250 that includes wavelength-shifting material 310 and a plasmonic or dielectric structure 800 may radiate greater than or equal to 40% of the total emitted-light signal 255 in the forward direction 360. In particular embodiments, wavelength-shifting element 250 may include a plasmonic or dielectric structure 800 that receives a portion of the emitted light 255 and causes the received portion of emitted light 255 to be concentrated as a converging beam (e.g., concentrated light 265) directed onto active region 272 of photodetector 270. As an example and not by way of limitation, a plasmonic or dielectric structure 800 may be configured so that emitted light 255 is emitted in a concentrated or converging manner. The emitted light 255 may be concentrated directly onto active region 272 of photodetector 270 without the need for a separate, discrete focusing element located outside of the wavelength-shifting element 250. In particular embodiments, a wavelength-shifting element 250 that includes a plasmonic or dielectric structure 800 that produces emitted light 255 in a concentrated or converging manner may be referred to as a wavelength-shifting element 250 that includes or incorporates a concentrating element 260. In particular embodiments, the emitted-light signal 255 may be substantially insensitive to the angle of incidence Θ of input optical signal 240. As an example and not by way of limitation, for each input beam 240A, 240B, or 240C, the resulting emitted optical signal 255 radiated in the forward direction 360 may have substantially the same wavelength range, optical intensity, and directional character.

FIG. 9 illustrates an example luminescent detector 230 that includes an example plasmonic or dielectric structure 800. In particular embodiments, luminescent detector 230 may include wavelength-shifting element 250 and photodetector 270. As illustrated in FIG. 9, wavelength-shifting element 250 may include wavelength-shifting material 310 and plasmonic or dielectric structure 800. Additionally, wavelength-shifting element 250 may be affixed to substrate 600. As illustrated in FIG. 9, the wavelength-shifting element 250 may be configured to receive input optical signal 240 and, through a fluorescence process, produce an emitted-light signal in the form of concentrated light 265. The emitted-light signal produced by wavelength-shifting element 250 may be directly emitted as concentrated light 265 that converges onto active region 272 of photodetector 270 without requiring a separate focusing element. In the luminescent detector 230 of FIG. 9, the wavelength-shifting element 250 performs both a wavelength-shifting operation as well as a concentrating operation. In particular embodiments, a wavelength-shifting element 250 illustrated in FIG. 9 that includes a plasmonic or dielectric structure 800 that emits light in a concentrated or converging manner may be referred to as a wavelength-shifting element 250 that includes or incorporates a concentrating element 260. As an example and not by way of limitation, the wavelength-shifting element 250 may be referred to as producing an emitted-light signal 255, receiving at least a portion of the emitted-light signal 255, and concentrating the received portion to produce concentrated light 265. In particular embodiments, a plasmonic or dielectric structure 800 may cause the emitted light 255 to be radiated in one or more concentrated or collimated beams, one of the concentrated or

collimated beams directed toward photodetector 270. As an example and not by way of limitation, concentrated light 265 directed toward photodetector 270 may include greater than or equal to 40% of the total amount of wavelength-shifted light 255 produced by wavelength-shifting element 250.

In particular embodiments, a luminescent detector 230 as illustrated in FIG. 9 may offer performance advantages similar to those described above with respect to the luminescent detector 230 illustrated in FIG. 7. As an example and not by way of limitation, luminescent detector 230 in FIG. 9 may offer a relatively large effective detector area, a relatively fast response time, a relatively large FOV, and relative insensitivity to wavefront distortion or phase fluctuations of input optical signal 240. Additionally, a luminescent detector 230 that includes a plasmonic or dielectric structure 800 may offer increased optical efficiency by producing light that is emitted in a directional or concentrated manner onto active region 272 of photodetector 270.

FIG. 10 illustrates an example method for detecting an optical signal using a luminescent detector 230. The method may begin at step 1010, where an input-light signal 240 may be received. As an example and not by way of limitation, a luminescent detector 230 may include a wavelength-shifting element 250 that receives the input-light signal 240. In particular embodiments, the wavelength-shifting element 250 may include a wavelength-shifting material 310. At step 1020, at least a portion of the received input-light signal 240 may be absorbed. As an example and not by way of limitation, the wavelength-shifting material 310 may absorb at least a portion of the received input-light signal 240. At step 1030, an emitted-light signal 255 may be produced from the absorbed portion of the received input-light signal 240. As an example and not by way of limitation, the wavelength-shifting material 310 may produce an emitted-light signal 255 from the absorbed portion of the received input-light signal 240. At step 1040, at least a portion of the emitted-light signal 255 may be received. As an example and not by way of limitation, an optical-concentrating element 260 may receive at least a portion of the emitted-light signal 255. At step 1050, the received portion of the emitted-light signal 255 may be concentrated. As an example and not by way of limitation, an optical-concentrating element 260 may concentrate the received portion of the emitted-light signal 255 onto active region 272 of photodetector 270. As another example and not by way of limitation, the optical-concentrating element 260 may be incorporated into the wavelength-shifting element 250, and the wavelength-shifting element 250 may receive at least a portion of the emitted-light signal 255 and concentrate the received portion as concentrated light 265 onto active region 272 of photodetector 270. At step 1060, the concentrated portion 265 of the emitted-light signal 255 may be received. As an example and not by way of limitation, a photodetector 270 may receive the concentrated portion 265 of the emitted-light signal 255. At step 1070, an electrical current 275 corresponding to the concentrated portion 265 of the emitted-light signal 255 may be produced. As an example and not by way of limitation, a photodetector 270 may produce an electrical current 275 corresponding to the concentrated portion 265 of the emitted-light signal 255. Particular embodiments may repeat one or more steps of the method of FIG. 10, where appropriate. Although this disclosure describes and illustrates particular steps of the method of FIG. 10 as occurring in a particular order, this disclosure contemplates any suitable steps of the method of FIG. 10 occurring in any suitable order. Moreover, although this disclosure describes and illustrates an example method for detecting an optical signal using a

luminescent detector **230** including the particular steps of the method of FIG. **10**, this disclosure contemplates any suitable method for detecting an optical signal using a luminescent detector **230** including any suitable steps, which may include all, some, or none of the steps of the method of FIG. **10**, where appropriate. Furthermore, although this disclosure describes and illustrates particular components, devices, or systems carrying out particular steps of the method of FIG. **10**, this disclosure contemplates any suitable combination of any suitable components, devices, or systems carrying out any suitable steps of the method of FIG. **10**.

FIG. **11** illustrates an example computer system **1100**. In particular embodiments, one or more computer systems **1100** perform one or more steps of one or more methods described or illustrated herein. In particular embodiments, one or more computer systems **1100** provide functionality described or illustrated herein. In particular embodiments, software running on one or more computer systems **1100** performs one or more steps of one or more methods described or illustrated herein or provides functionality described or illustrated herein. Particular embodiments include one or more portions of one or more computer systems **1100**. Herein, reference to a computer system may encompass a computing device, and vice versa, where appropriate. Moreover, reference to a computer system may encompass one or more computer systems, where appropriate.

This disclosure contemplates any suitable number of computer systems **1100**. This disclosure contemplates computer system **1100** taking any suitable physical form. As example and not by way of limitation, computer system **1100** may be an embedded computer system, a system-on-chip (SOC), a single-board computer system (SBC) (such as, for example, a computer-on-module (COM) or system-on-module (SOM)), a desktop computer system, a laptop or notebook computer system, an interactive kiosk, a mainframe, a mesh of computer systems, a mobile telephone, a personal digital assistant (PDA), a server, a tablet computer system, an augmented/virtual reality device, or a combination of two or more of these. Where appropriate, computer system **1100** may include one or more computer systems **1100**; be unitary or distributed; span multiple locations; span multiple machines; span multiple data centers; or reside in a cloud, which may include one or more cloud components in one or more networks. Where appropriate, one or more computer systems **1100** may perform without substantial spatial or temporal limitation one or more steps of one or more methods described or illustrated herein. As an example and not by way of limitation, one or more computer systems **1100** may perform in real time or in batch mode one or more steps of one or more methods described or illustrated herein. One or more computer systems **1100** may perform at different times or at different locations one or more steps of one or more methods described or illustrated herein, where appropriate.

In particular embodiments, computer system **1100** includes a processor **1102**, memory **1104**, storage **1106**, an input/output (I/O) interface **1108**, a communication interface **1110**, and a bus **1112**. Although this disclosure describes and illustrates a particular computer system having a particular number of particular components in a particular arrangement, this disclosure contemplates any suitable computer system having any suitable number of any suitable components in any suitable arrangement.

In particular embodiments, processor **1102** includes hardware for executing instructions, such as those making up a

computer program. As an example and not by way of limitation, to execute instructions, processor **1102** may retrieve (or fetch) the instructions from an internal register, an internal cache, memory **1104**, or storage **1106**; decode and execute them; and then write one or more results to an internal register, an internal cache, memory **1104**, or storage **1106**. In particular embodiments, processor **1102** may include one or more internal caches for data, instructions, or addresses. This disclosure contemplates processor **1102** including any suitable number of any suitable internal caches, where appropriate. As an example and not by way of limitation, processor **1102** may include one or more instruction caches, one or more data caches, and one or more translation lookaside buffers (TLBs). Instructions in the instruction caches may be copies of instructions in memory **1104** or storage **1106**, and the instruction caches may speed up retrieval of those instructions by processor **1102**. Data in the data caches may be copies of data in memory **1104** or storage **1106** for instructions executing at processor **1102** to operate on; the results of previous instructions executed at processor **1102** for access by subsequent instructions executing at processor **1102** or for writing to memory **1104** or storage **1106**; or other suitable data. The data caches may speed up read or write operations by processor **1102**. The TLBs may speed up virtual-address translation for processor **1102**. In particular embodiments, processor **1102** may include one or more internal registers for data, instructions, or addresses. This disclosure contemplates processor **1102** including any suitable number of any suitable internal registers, where appropriate. Where appropriate, processor **1102** may include one or more arithmetic logic units (ALUs); be a multi-core processor; or include one or more processors **1102**. Although this disclosure describes and illustrates a particular processor, this disclosure contemplates any suitable processor.

In particular embodiments, memory **1104** includes main memory for storing instructions for processor **1102** to execute or data for processor **1102** to operate on. As an example and not by way of limitation, computer system **1100** may load instructions from storage **1106** or another source (such as, for example, another computer system **1100**) to memory **1104**. Processor **1102** may then load the instructions from memory **1104** to an internal register or internal cache. To execute the instructions, processor **1102** may retrieve the instructions from the internal register or internal cache and decode them. During or after execution of the instructions, processor **1102** may write one or more results (which may be intermediate or final results) to the internal register or internal cache. Processor **1102** may then write one or more of those results to memory **1104**. In particular embodiments, processor **1102** executes only instructions in one or more internal registers or internal caches or in memory **1104** (as opposed to storage **1106** or elsewhere) and operates only on data in one or more internal registers or internal caches or in memory **1104** (as opposed to storage **1106** or elsewhere). One or more memory buses (which may each include an address bus and a data bus) may couple processor **1102** to memory **1104**. Bus **1112** may include one or more memory buses, as described below. In particular embodiments, one or more memory management units (MMUs) reside between processor **1102** and memory **1104** and facilitate accesses to memory **1104** requested by processor **1102**. In particular embodiments, memory **1104** includes random access memory (RAM). This RAM may be volatile memory, where appropriate. Where appropriate, this RAM may be dynamic RAM (DRAM) or static RAM (SRAM). Moreover, where appropriate, this RAM may be

single-ported or multi-ported RAM. This disclosure contemplates any suitable RAM. Memory **1104** may include one or more memories **1104**, where appropriate. Although this disclosure describes and illustrates particular memory, this disclosure contemplates any suitable memory.

In particular embodiments, storage **1106** includes mass storage for data or instructions. As an example and not by way of limitation, storage **1106** may include a hard disk drive (HDD), a floppy disk drive, flash memory, an optical disc, a magneto-optical disc, magnetic tape, or a Universal Serial Bus (USB) drive or a combination of two or more of these. Storage **1106** may include removable or non-removable (or fixed) media, where appropriate. Storage **1106** may be internal or external to computer system **1100**, where appropriate. In particular embodiments, storage **1106** is non-volatile, solid-state memory. In particular embodiments, storage **1106** includes read-only memory (ROM). Where appropriate, this ROM may be mask-programmed ROM, programmable ROM (PROM), erasable PROM (EPROM), electrically erasable PROM (EEPROM), electrically alterable ROM (EAROM), or flash memory or a combination of two or more of these. This disclosure contemplates mass storage **1106** taking any suitable physical form. Storage **1106** may include one or more storage control units facilitating communication between processor **1102** and storage **1106**, where appropriate. Where appropriate, storage **1106** may include one or more storages **1106**. Although this disclosure describes and illustrates particular storage, this disclosure contemplates any suitable storage.

In particular embodiments, I/O interface **1108** includes hardware, software, or both, providing one or more interfaces for communication between computer system **1100** and one or more I/O devices. Computer system **1100** may include one or more of these I/O devices, where appropriate. One or more of these I/O devices may enable communication between a person and computer system **1100**. As an example and not by way of limitation, an I/O device may include a keyboard, keypad, microphone, monitor, mouse, printer, scanner, speaker, still camera, stylus, tablet, touch screen, trackball, video camera, another suitable I/O device or a combination of two or more of these. An I/O device may include one or more sensors. This disclosure contemplates any suitable I/O devices and any suitable I/O interfaces **1108** for them. Where appropriate, I/O interface **1108** may include one or more device or software drivers enabling processor **1102** to drive one or more of these I/O devices. I/O interface **1108** may include one or more I/O interfaces **1108**, where appropriate. Although this disclosure describes and illustrates a particular I/O interface, this disclosure contemplates any suitable I/O interface.

In particular embodiments, communication interface **1110** includes hardware, software, or both providing one or more interfaces for communication (such as, for example, packet-based communication) between computer system **1100** and one or more other computer systems **1100** or one or more networks. As an example and not by way of limitation, communication interface **1110** may include a network interface controller (NIC) or network adapter for communicating with an Ethernet or other wire-based network or a wireless NIC (WNIC) or wireless adapter for communicating with a wireless network, such as a WI-FI network. This disclosure contemplates any suitable network and any suitable communication interface **1110** for it. As an example and not by way of limitation, computer system **1100** may communicate with an ad hoc network, a personal area network (PAN), a local area network (LAN), a wide area network (WAN), a metropolitan area network (MAN), or one or more portions

of the Internet or a combination of two or more of these. One or more portions of one or more of these networks may be wired or wireless. As an example, computer system **1100** may communicate with a wireless PAN (WPAN) (such as, for example, a BLUETOOTH WPAN), a WI-FI network, a WI-MAX network, a cellular telephone network (such as, for example, a Global System for Mobile Communications (GSM) network), or other suitable wireless network or a combination of two or more of these. Computer system **1100** may include any suitable communication interface **1110** for any of these networks, where appropriate. Communication interface **1110** may include one or more communication interfaces **1110**, where appropriate. Although this disclosure describes and illustrates a particular communication interface, this disclosure contemplates any suitable communication interface.

In particular embodiments, bus **1112** includes hardware, software, or both coupling components of computer system **1100** to each other. As an example and not by way of limitation, bus **1112** may include an Accelerated Graphics Port (AGP) or other graphics bus, an Enhanced Industry Standard Architecture (EISA) bus, a front-side bus (FSB), a HYPERTRANSPORT (HT) interconnect, an Industry Standard Architecture (ISA) bus, an INFINIBAND interconnect, a low-pin-count (LPC) bus, a memory bus, a Micro Channel Architecture (MCA) bus, a Peripheral Component Interconnect (PCI) bus, a PCI-Express (PCIe) bus, a serial advanced technology attachment (SATA) bus, a Video Electronics Standards Association local (VLB) bus, or another suitable bus or a combination of two or more of these. Bus **1112** may include one or more buses **1112**, where appropriate. Although this disclosure describes and illustrates a particular bus, this disclosure contemplates any suitable bus or interconnect.

Herein, a computer-readable non-transitory storage medium or media may include one or more semiconductor-based or other integrated circuits (ICs) (such, as for example, field-programmable gate arrays (FPGAs) or application-specific ICs (ASICs)), hard disk drives (HDDs), hybrid hard drives (HHDs), optical discs, optical disc drives (ODDs), magneto-optical discs, magneto-optical drives, floppy diskettes, floppy disk drives (FDDs), magnetic tapes, solid-state drives (SSDs), RAM-drives, SECURE DIGITAL cards or drives, any other suitable computer-readable non-transitory storage media, or any suitable combination of two or more of these, where appropriate. A computer-readable non-transitory storage medium may be volatile, non-volatile, or a combination of volatile and non-volatile, where appropriate.

Herein, “or” is inclusive and not exclusive, unless expressly indicated otherwise or indicated otherwise by context. Therefore, herein, “A or B” means “A, B, or both,” unless expressly indicated otherwise or indicated otherwise by context. Moreover, “and” is both joint and several, unless expressly indicated otherwise or indicated otherwise by context. Therefore, herein, “A and B” means “A and B, jointly or severally,” unless expressly indicated otherwise or indicated otherwise by context.

The scope of this disclosure encompasses all changes, substitutions, variations, alterations, and modifications to the example embodiments described or illustrated herein that a person having ordinary skill in the art would comprehend. The scope of this disclosure is not limited to the example embodiments described or illustrated herein. Moreover, although this disclosure describes and illustrates respective embodiments herein as including particular components, elements, feature, functions, operations, or steps, any of

these embodiments may include any combination or permutation of any of the components, elements, features, functions, operations, or steps described or illustrated anywhere herein that a person having ordinary skill in the art would comprehend. Furthermore, reference in the appended claims to an apparatus or system or a component of an apparatus or system being adapted to, arranged to, capable of, configured to, enabled to, operable to, or operative to perform a particular function encompasses that apparatus, system, component, whether or not it or that particular function is activated, turned on, or unlocked, as long as that apparatus, system, or component is so adapted, arranged, capable, configured, enabled, operable, or operative. Additionally, although this disclosure describes or illustrates particular embodiments as providing particular advantages, particular embodiments may provide none, some, or all of these advantages.

The invention claimed is:

1. An apparatus comprising:

a wavelength-shifting element comprising:
 a photoluminescent wavelength-shifting material configured to:

receive, from a first direction, an input-light data signal comprising a first range of wavelengths;
 absorb at least a portion of the received input-light data signal; and
 produce, based on an upper-state lifetime of the photoluminescent wavelength-shifting material, an emitted-light data signal comprising a second range of wavelengths;

a plasmonic structure that emits the emitted-light data signal in an opposite direction from the first direction;

a focusing element configured to:
 receive, from the opposite direction, at least a portion of the emitted-light data signal;

concentrate the received portion of the emitted-light data signal; and
 produce a concentrated-light data signal; and

a photodetector configured to:
 receive the concentrated-light data signal; and
 produce an electrical current corresponding to the concentrated-light data signal.

2. The apparatus of claim 1, wherein the input-light data signal is a free-space optical-communication signal sent from an optical transmitter.

3. The apparatus of claim 1, wherein the photoluminescent wavelength-shifting material has an upper-state lifetime of less than or equal to 10 nanoseconds.

4. The apparatus of claim 1, wherein the photoluminescent wavelength-shifting material is contained within an encapsulant material.

5. The apparatus of claim 4, wherein an upper-state lifetime of the photoluminescent wavelength-shifting material is reduced due to properties of the encapsulant material.

6. The apparatus of claim 4, wherein a quantum efficiency of the photoluminescent wavelength-shifting material is increased due to properties of the encapsulant material.

7. The apparatus of claim 1, wherein the photoluminescent wavelength-shifting material has a thickness between 0.05 μm and 1 mm.

8. The apparatus of claim 1, wherein the photoluminescent wavelength-shifting material comprises a fluorescent-dye material or a plurality of quantum dots.

9. The apparatus of claim 1, wherein the photoluminescent wavelength-shifting material is a non-isotropic emitter

that radiates the emitted-light data signal in a forward direction or a backward direction.

10. The apparatus of claim 1, wherein the photoluminescent wavelength-shifting material absorbs greater than or equal to 70% of the input-light data signal.

11. The apparatus of claim 1, wherein the absorbed portion of the received input-light data signal comprises visible or near-infrared light and the emitted-light data signal has a wavelength range that is longer than a wavelength range of the absorbed portion of the received input-light data signal.

12. The apparatus of claim 1, wherein:
 the photoluminescent wavelength-shifting material comprises an input aperture configured to receive the input-light data signal, wherein the input aperture has a diameter or width of greater than or equal to 1 cm; and
 the photodetector has an active element with a diameter or width of less than or equal to 1 mm.

13. The apparatus of claim 1, wherein:
 the photoluminescent wavelength-shifting material comprises an input aperture configured to receive the input-light data signal, wherein the input aperture has a diameter or width of greater than or equal to 1 mm; and
 the photodetector has an active element with a diameter or width of less than or equal to 20 micrometers.

14. The apparatus of claim 1, wherein the portion of the emitted-light data signal received by the focusing element comprises greater than or equal to 25% of the emitted-light data signal.

15. The apparatus of claim 1, wherein the plasmonic structure comprises a plurality of plasmonic-structure elements having diameters between 10 nm and 1 μm .

16. The apparatus of claim 15, wherein the plurality of plasmonic structure elements extends perpendicular to a side of the photoluminescent wavelength-shifting material.

17. The apparatus of claim 15, wherein the plasmonic structure is configured to cause the emitted-light data signal to be radiated in one or more collimated beams, one of the collimated beams directed in the opposite direction toward the focusing element.

18. A method comprising:
 receiving, from a first direction by a photoluminescent wavelength-shifting material, an input-light data signal comprising a first range of wavelengths;

absorbing at least a portion of the received input-light data signal;

producing based on an upper-state lifetime of the photoluminescent wavelength-shifting material, an emitted-light data signal comprising a second range of wavelengths;

emitting, by a plasmonic structure, the emitted-light data signal in an opposite direction from the first direction;

receiving, from the opposite direction by a focusing element, at least a portion of the emitted-light data signal;

concentrating the received portion of the emitted-light data signal;

producing a concentrated-light data signal;

receiving, by a photodetector, the concentrated-light data signal; and

producing an electrical current corresponding to the concentrated-light data signal.

19. The apparatus of claim 1, wherein the photodetector has a response time that is faster than the upper-state lifetime of the photoluminescent wavelength-shifting material.