



US010311565B2

(12) **United States Patent**
Terry

(10) **Patent No.:** **US 10,311,565 B2**
(45) **Date of Patent:** **Jun. 4, 2019**

(54) **CELL SITE EQUIPMENT VERIFICATION USING 3D MODELING COMPARISONS**

(71) Applicant: **Charlie Terry**, Charlotte, NC (US)

(72) Inventor: **Charlie Terry**, Charlotte, NC (US)

(73) Assignee: **ETAK Systems, LLC**, Huntersville, NC (US)

(*) Notice: Subject to any disclaimer, the term of this patent is extended or adjusted under 35 U.S.C. 154(b) by 27 days.

(21) Appl. No.: **15/466,400**

(22) Filed: **Mar. 22, 2017**

(65) **Prior Publication Data**

US 2018/0232871 A1 Aug. 16, 2018

Related U.S. Application Data

(63) Continuation-in-part of application No. 15/338,700, filed on Oct. 31, 2016, and a continuation-in-part of application No. 15/175,314, filed on Jun. 7, 2016, and a continuation-in-part of application No. 15/168,503, filed on May 31, 2016, now Pat. No. 9,704,292, and a continuation-in-part of application No. 15/160,890, filed on May 20, 2016, and a continuation-in-part of application No. 14/736,925, filed on Jun. 11, 2015, now Pat. No. 9,669,945, and a continuation-in-part of (Continued)

(51) **Int. Cl.**
G06T 17/05 (2011.01)
G06T 7/00 (2017.01)
G06K 9/00 (2006.01)
H04L 12/24 (2006.01)
B64C 39/02 (2006.01)
H04W 24/10 (2009.01)

(52) **U.S. Cl.**
CPC **G06T 7/001** (2013.01); **B64C 39/024** (2013.01); **G06K 9/00637** (2013.01); **G06T 17/05** (2013.01); **H04L 41/0869** (2013.01); **H04W 24/10** (2013.01); **B64C 2201/123** (2013.01); **B64C 2201/127** (2013.01); **G06T 2207/10028** (2013.01)

(58) **Field of Classification Search**
CPC **B64C 2201/027**; **B64C 2201/127**; **B64C 2201/00**; **G06T 17/00**
USPC **345/427**
See application file for complete search history.

(56) **References Cited**

U.S. PATENT DOCUMENTS

4,818,990 A 4/1989 Fernandes
8,346,578 B1 1/2013 Hopkins et al.
(Continued)

OTHER PUBLICATIONS

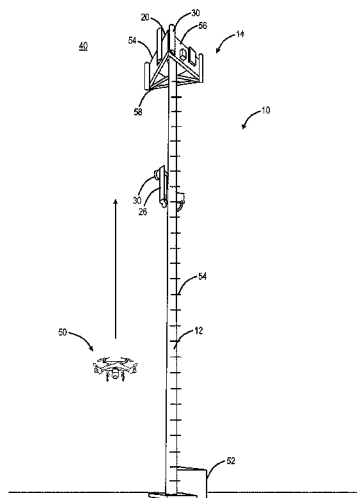
US 5,868,314 A1, 03/2005, Frink (withdrawn)
(Continued)

Primary Examiner — Thomas J Lett
(74) *Attorney, Agent, or Firm* — Clements Bernard Walker PLLC; Lawrence A. Baratta, Jr.

(57) **ABSTRACT**

Systems and method for verifying a cell site utilizing an Unmanned Aerial Vehicle (UAV) include providing an initial point cloud related to the cell site to the UAV; developing a second point cloud based on current conditions at the cell site, wherein the second point cloud is based on data acquisition using the UAV at the cell site; detecting variations between the initial point cloud and the second point cloud; and, responsive to detecting the variations, determining whether the variations are any of compliance related, load issues, and defects associated with any equipment or structures at the cell site.

14 Claims, 41 Drawing Sheets



Related U.S. Application Data

application No. 14/685,720, filed on Apr. 14, 2015,
now Pat. No. 9,596,617.

(56)

References Cited

U.S. PATENT DOCUMENTS

9,085,363	B2	7/2015	Tofte	
9,162,753	B1	10/2015	Panto	
9,439,092	B1*	9/2016	Chukka	H04W 24/04
9,536,149	B1*	1/2017	Cesarano	G05D 1/0214
2002/0193914	A1	12/2002	Talbert	
2010/0215212	A1	8/2010	Flakes	
2010/0231687	A1*	9/2010	Amory	H04N 5/232 348/36
2011/0221692	A1	9/2011	Seydoux et al.	
2012/0250010	A1	10/2012	Hannay	
2012/0262708	A1	10/2012	Connolly	
2013/0173088	A1	7/2013	Parrot	

2013/0233964	A1	9/2013	Woodworth	
2013/0325217	A1	12/2013	Parrot	
2014/0018976	A1	1/2014	Goossen et al.	
2014/0131510	A1	5/2014	Wang	
2014/0267627	A1*	9/2014	Freeman	G01S 17/023 348/47
2014/0277854	A1	9/2014	Jones	
2014/0298181	A1	10/2014	Rezvan	
2015/0304869	A1	10/2015	Johnson	
2017/0155456	A1*	6/2017	Wennerlof	H04B 17/12
2018/0032088	A1*	2/2018	van Cruyningen ...	B64C 39/024

OTHER PUBLICATIONS

Knutson et al., "In Race for Better Cell Service, Men Who Climb Towers Pay With Their Lives," PBS.org, pp. 1-12.
Knutson et al., "Methodology: How We Calculated the Tower Industry Death Rate," ProPublica, pp. 1-2.

* cited by examiner

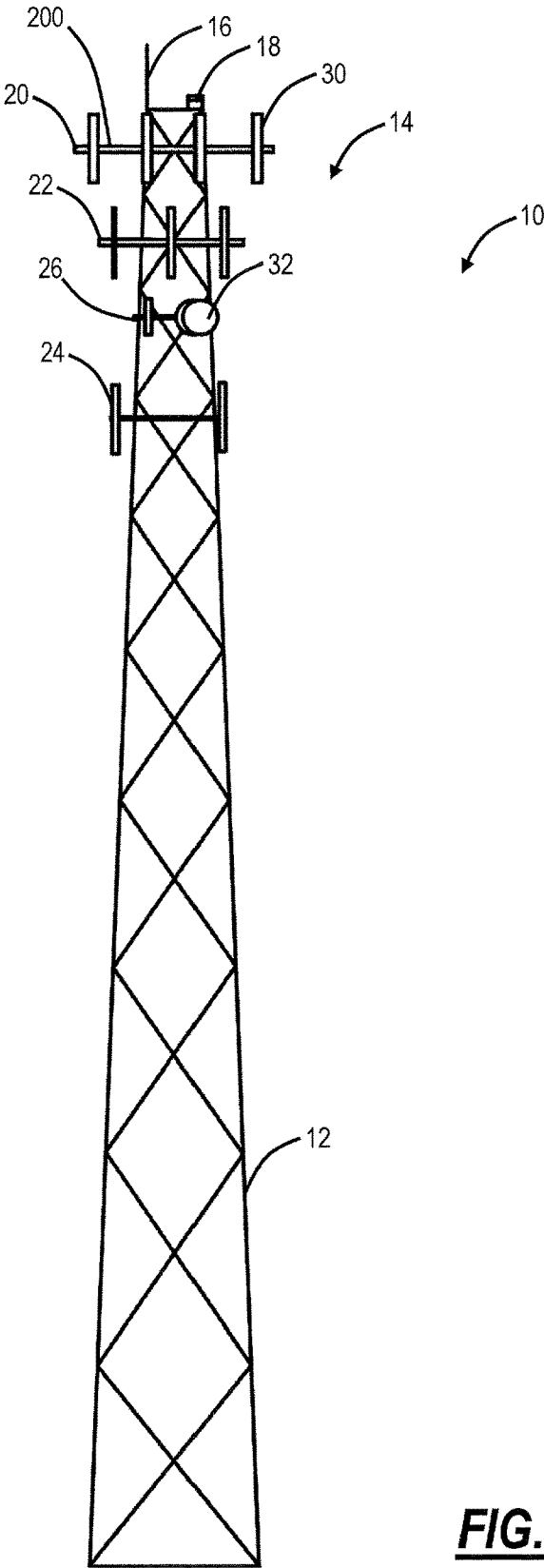


FIG. 1

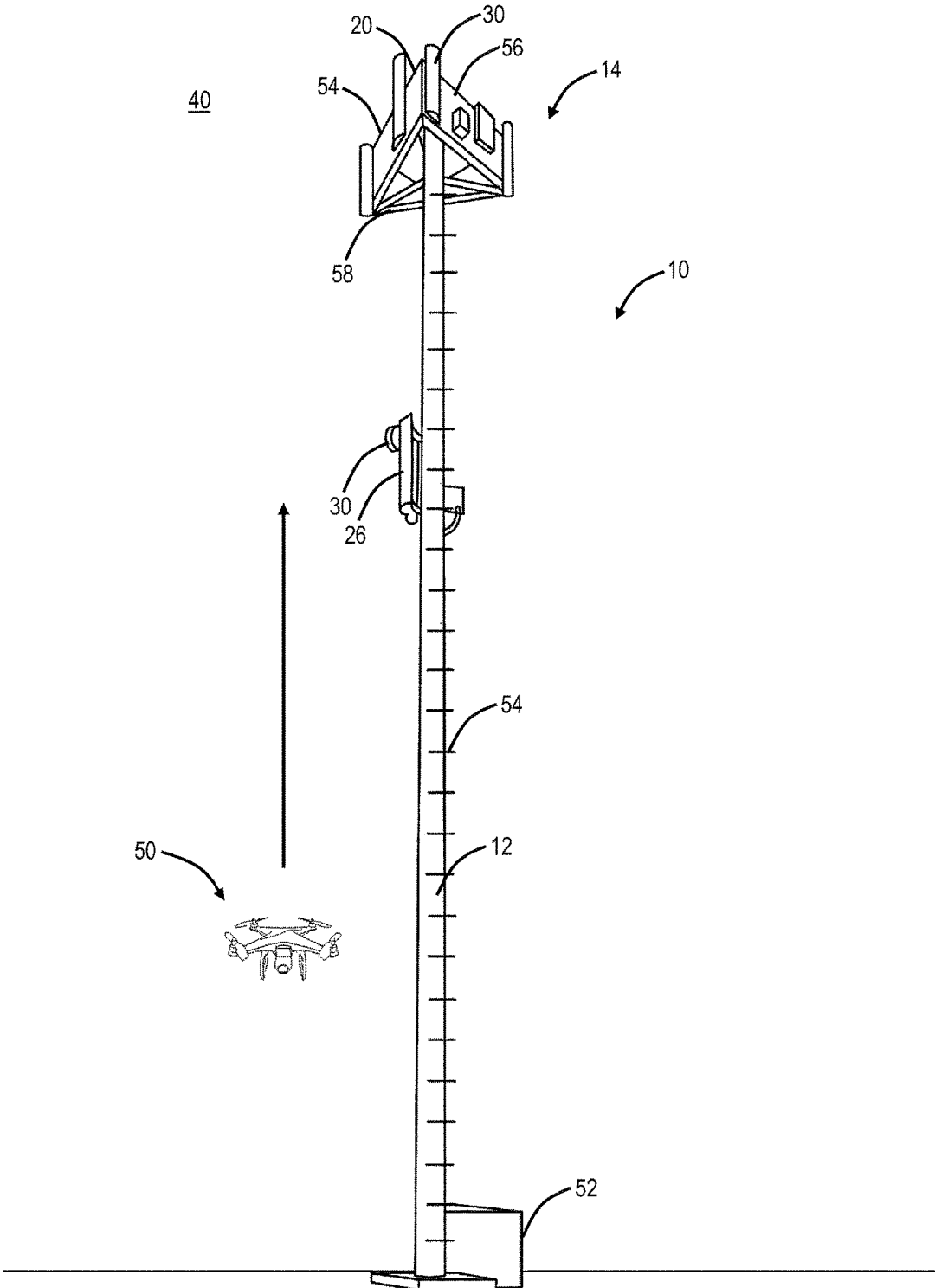


FIG. 2

60

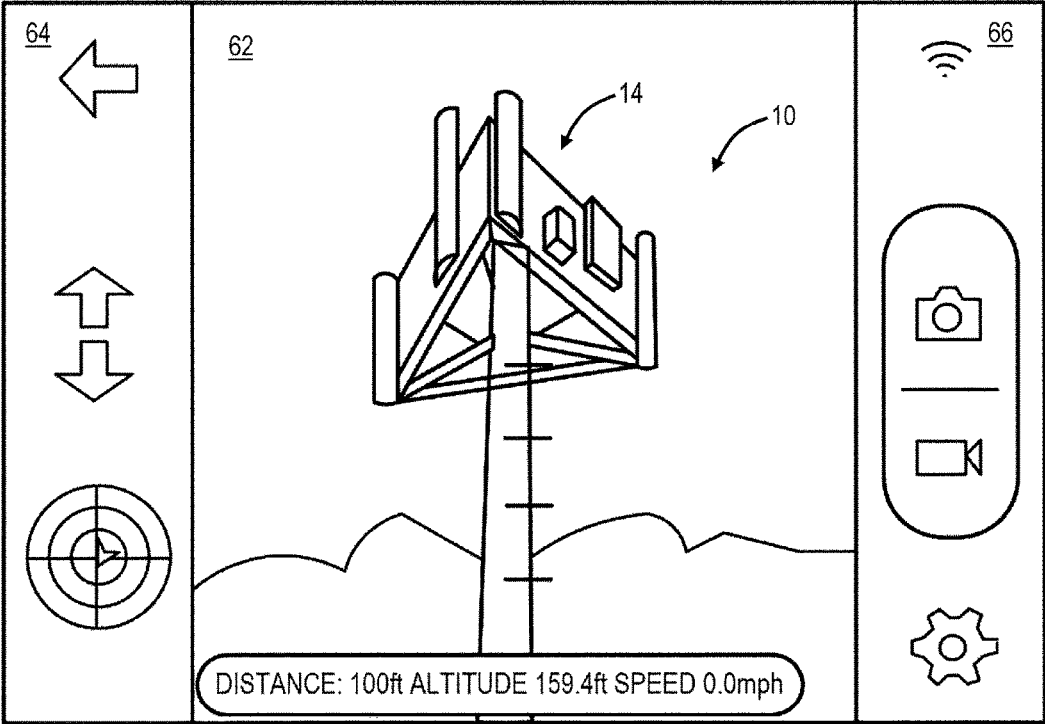


FIG. 3

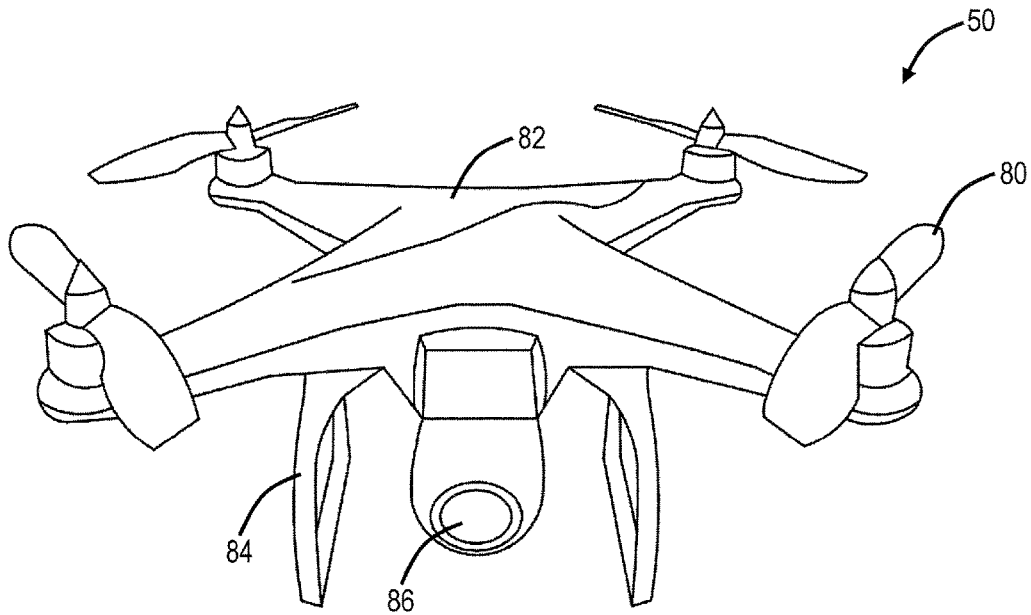


FIG. 4

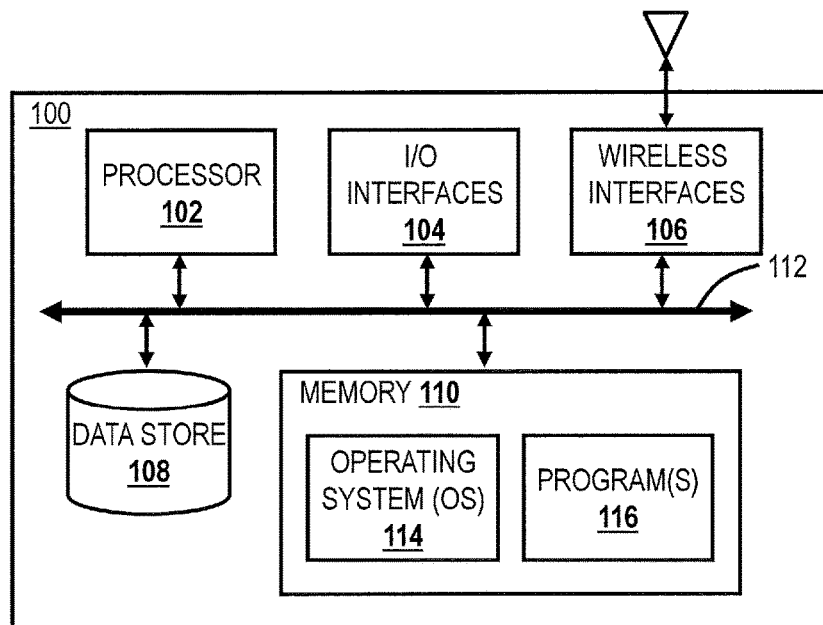


FIG. 5

FIG. 6

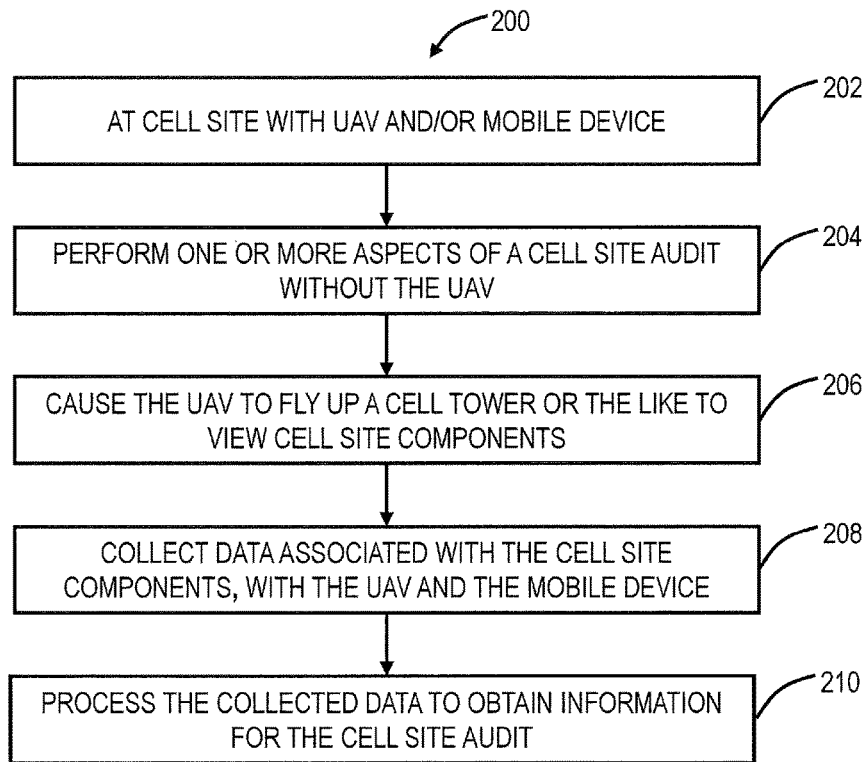
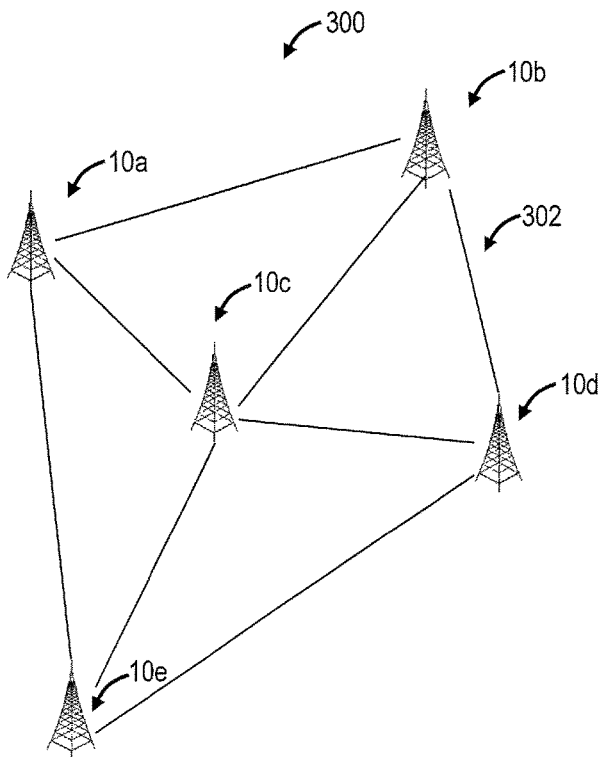


FIG. 7



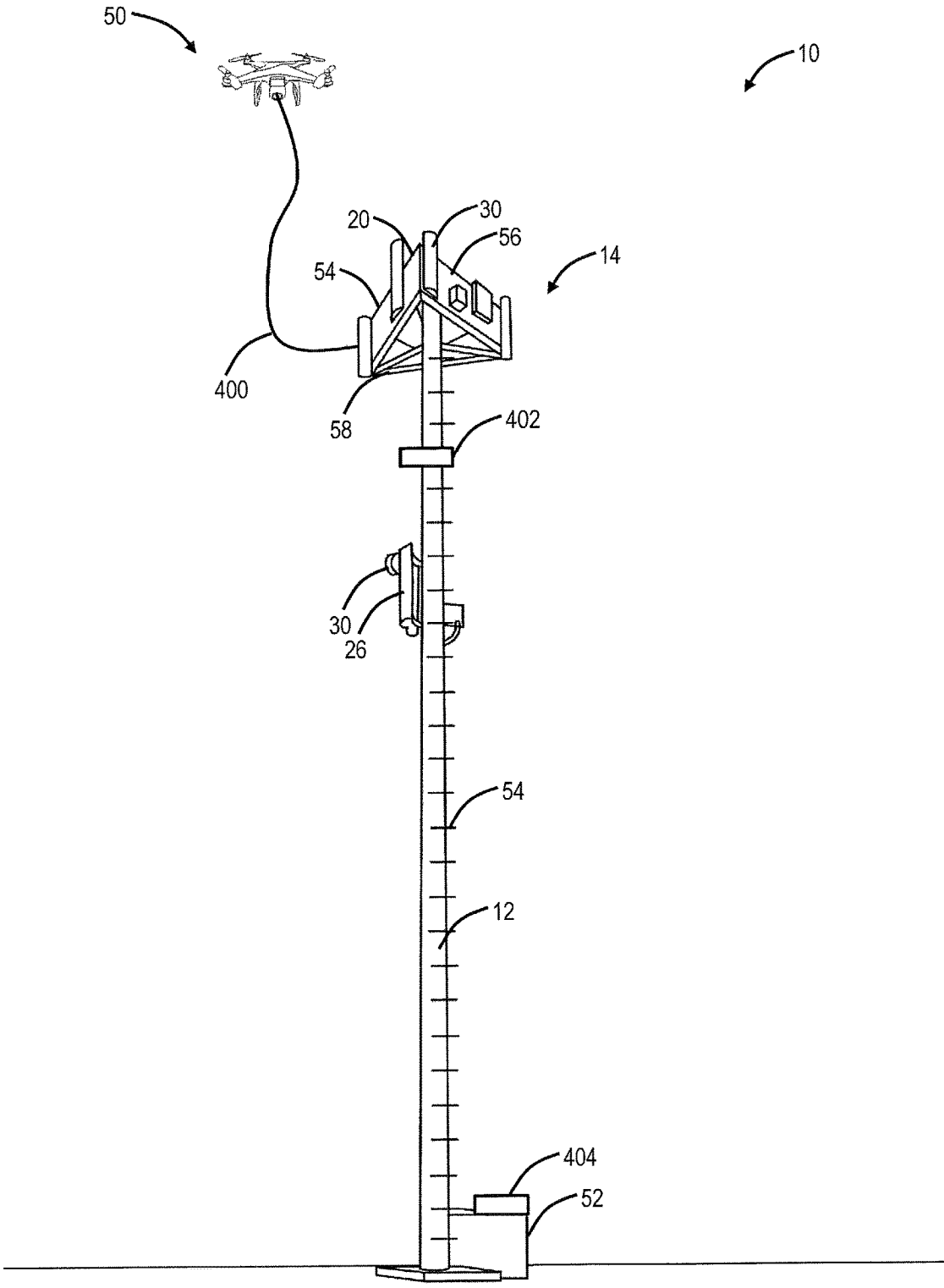


FIG. 8

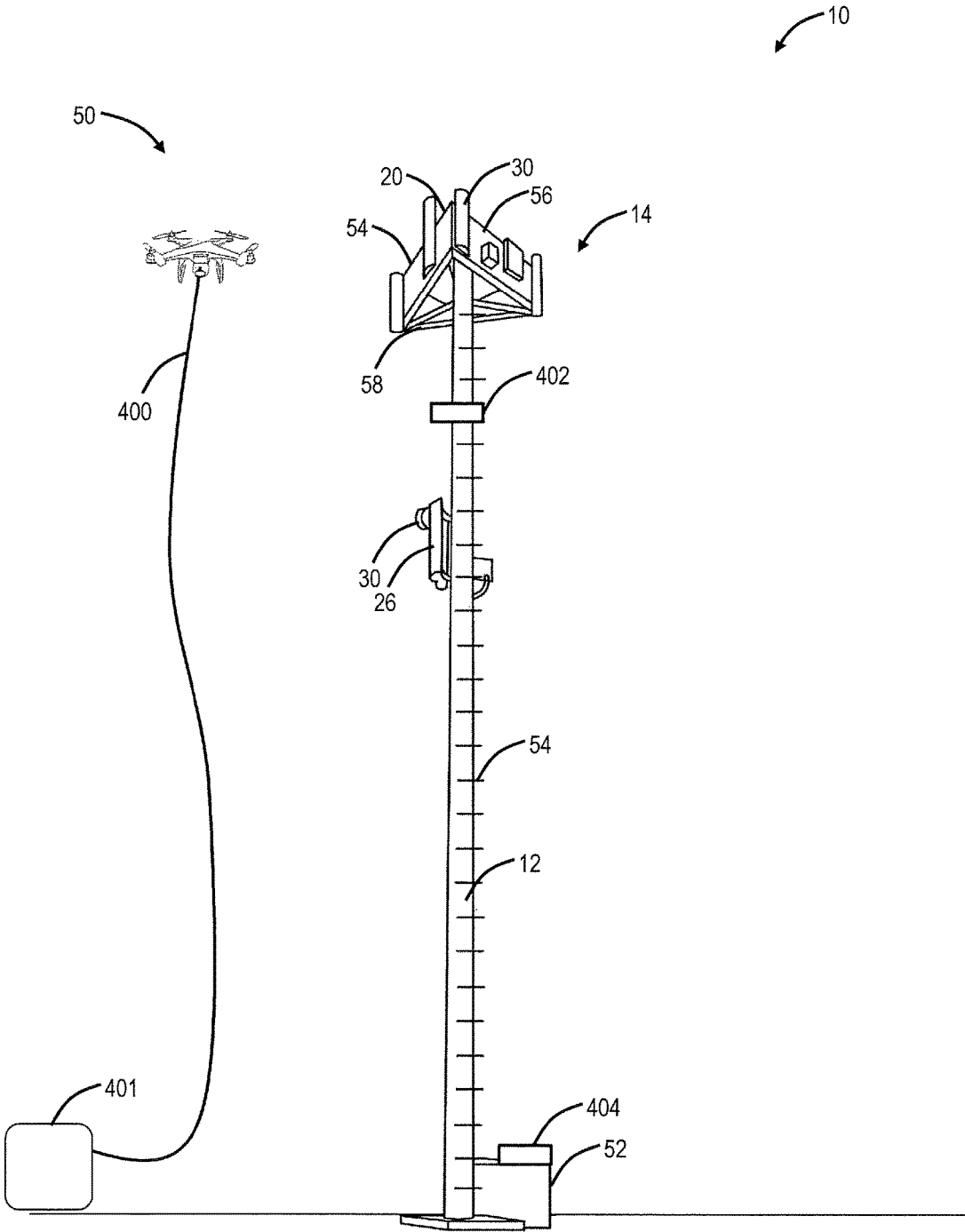


FIG. 9

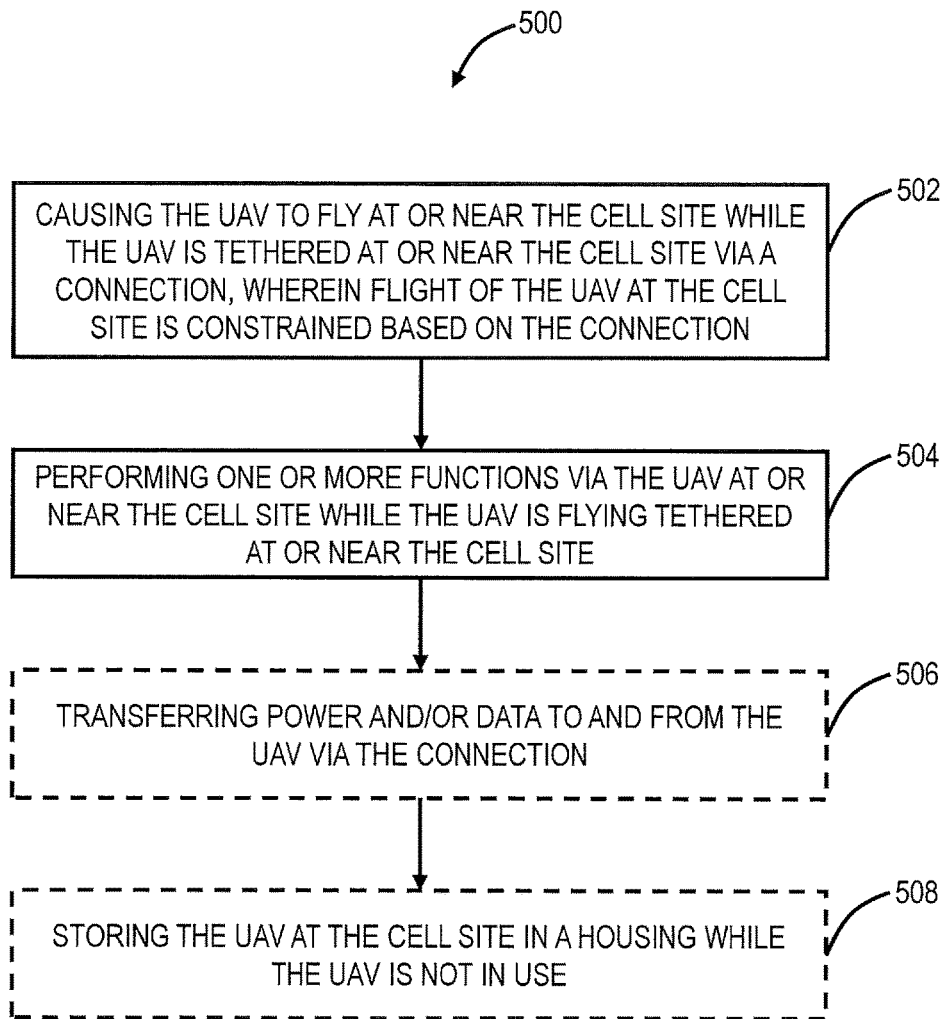


FIG. 10

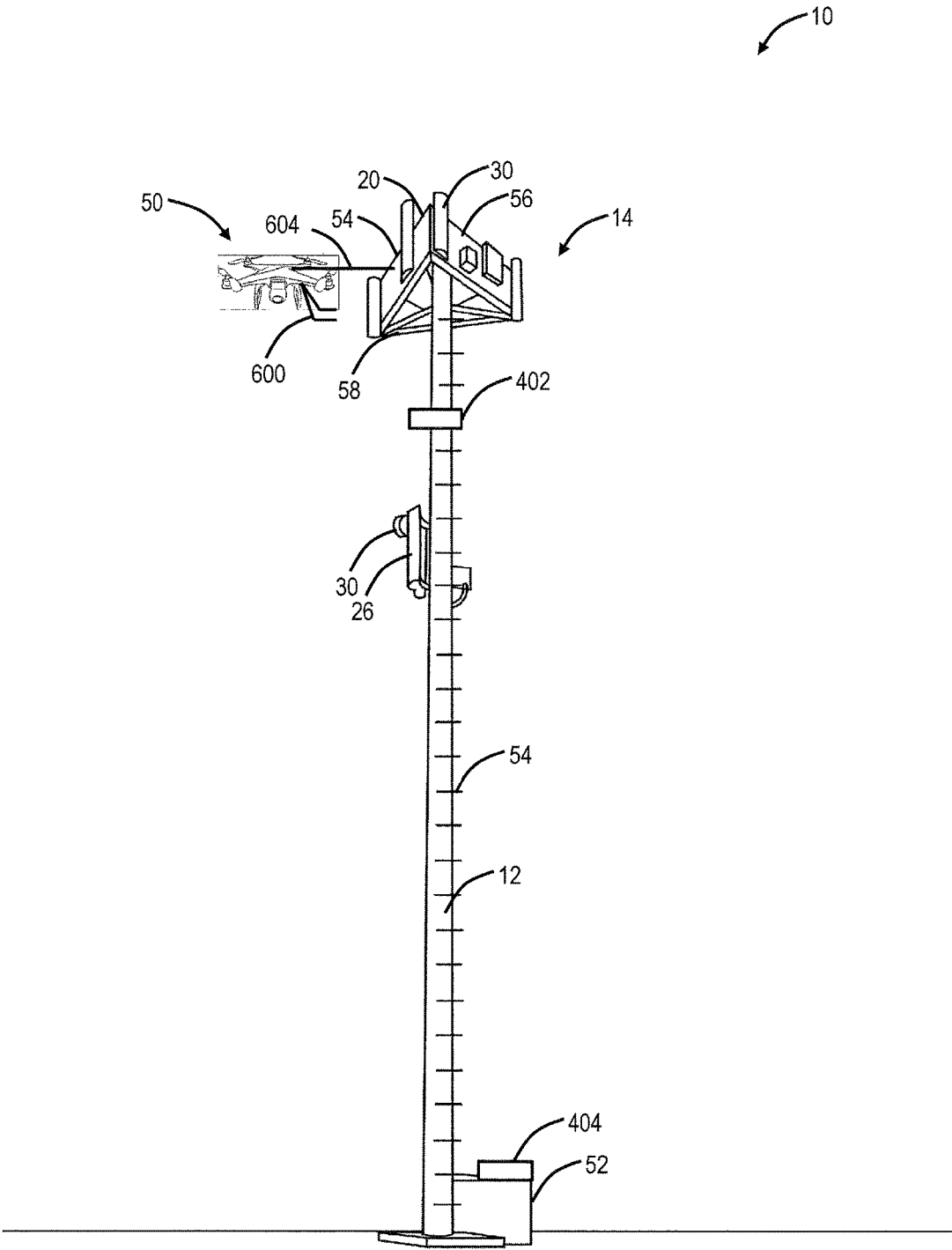


FIG. 11

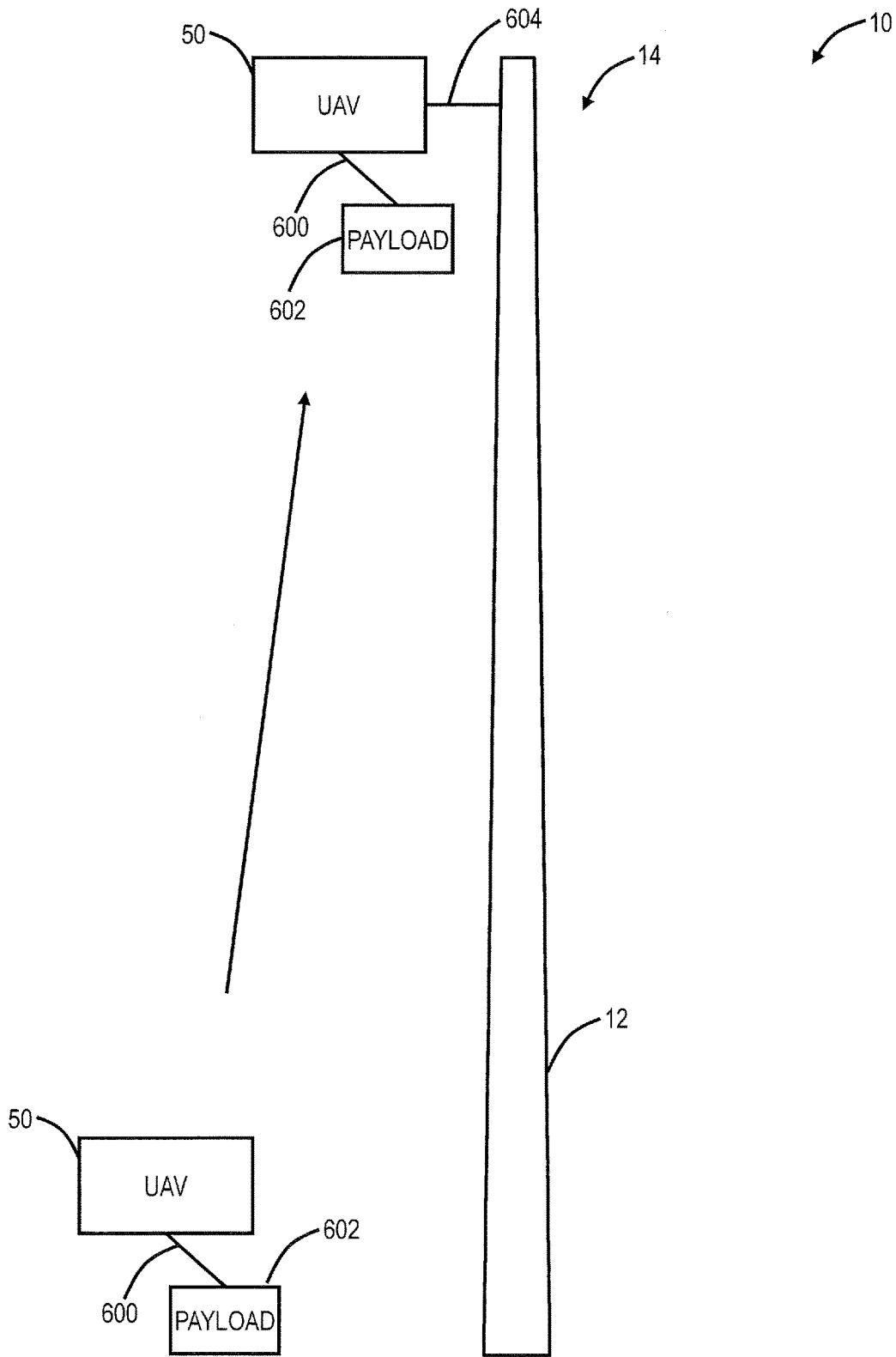


FIG. 12

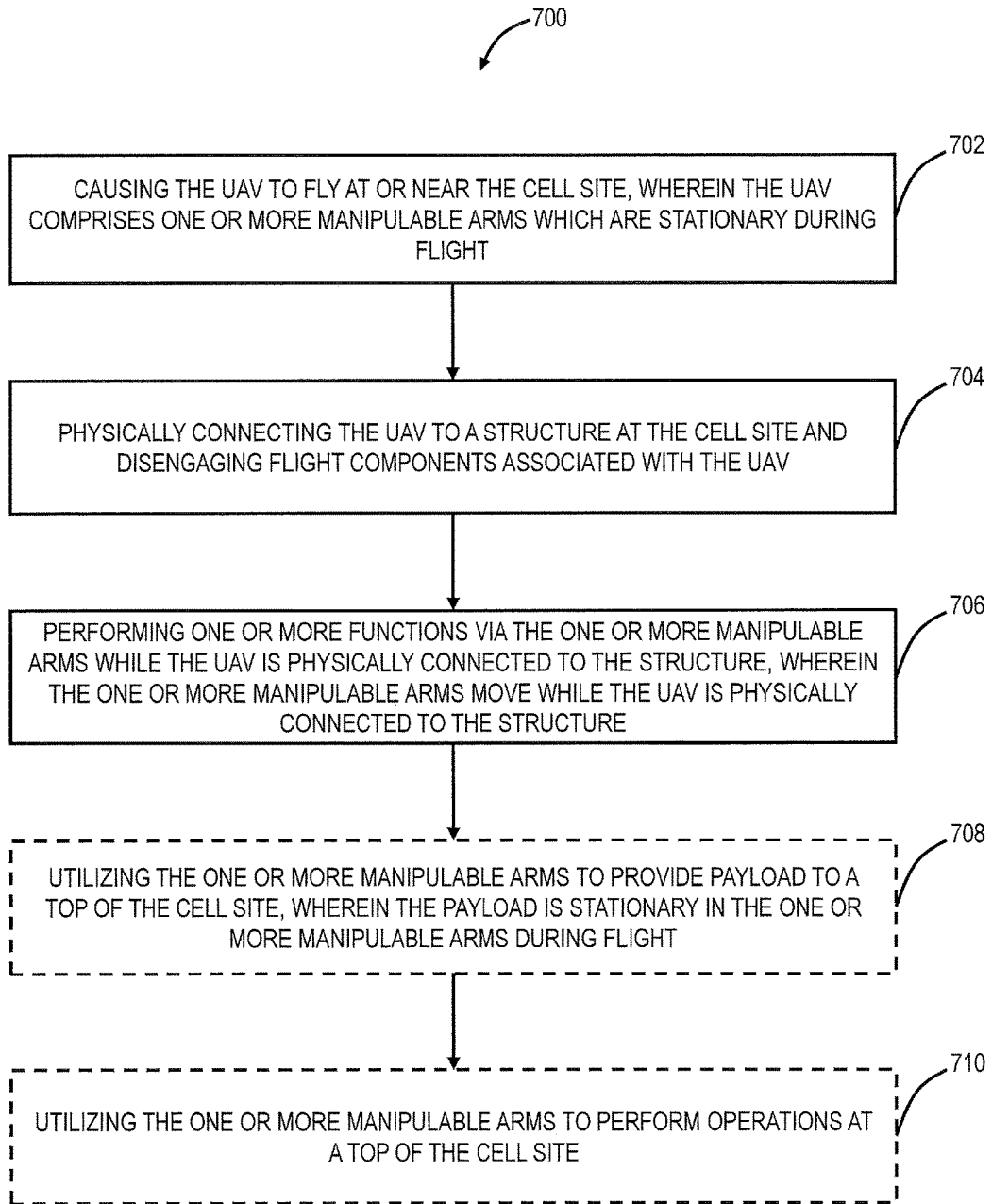


FIG. 13

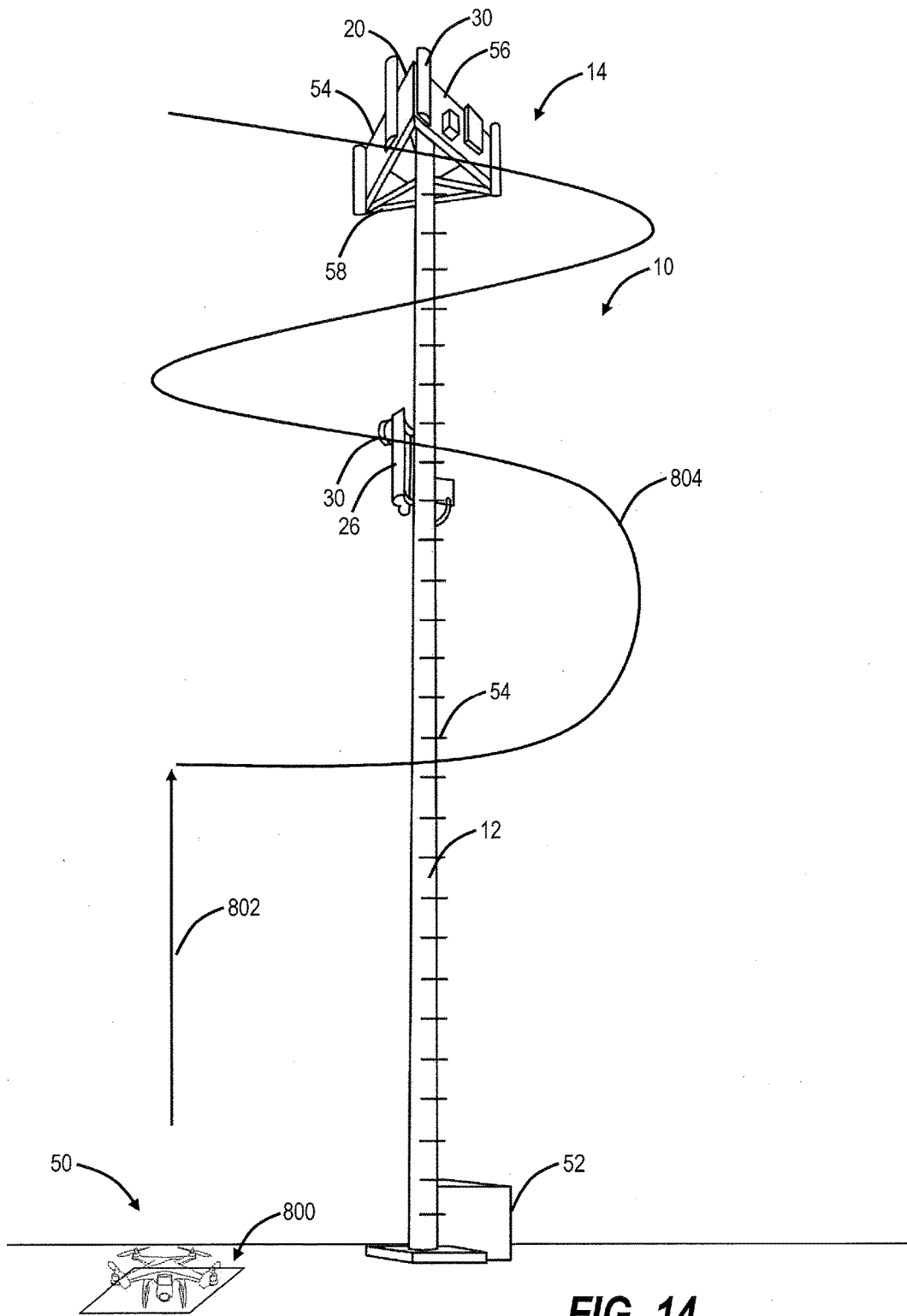


FIG. 14



FIG. 15

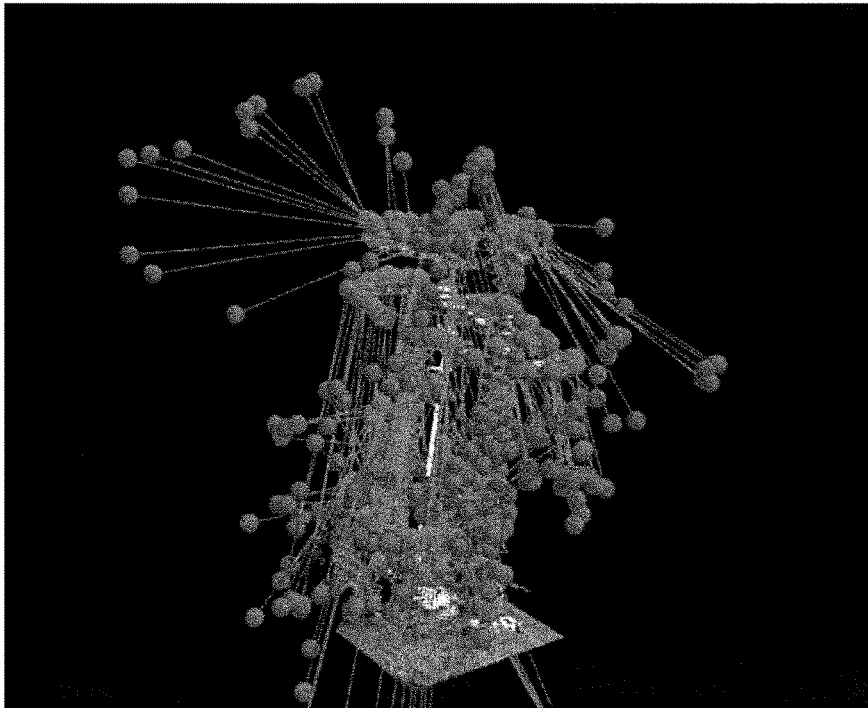


FIG. 16

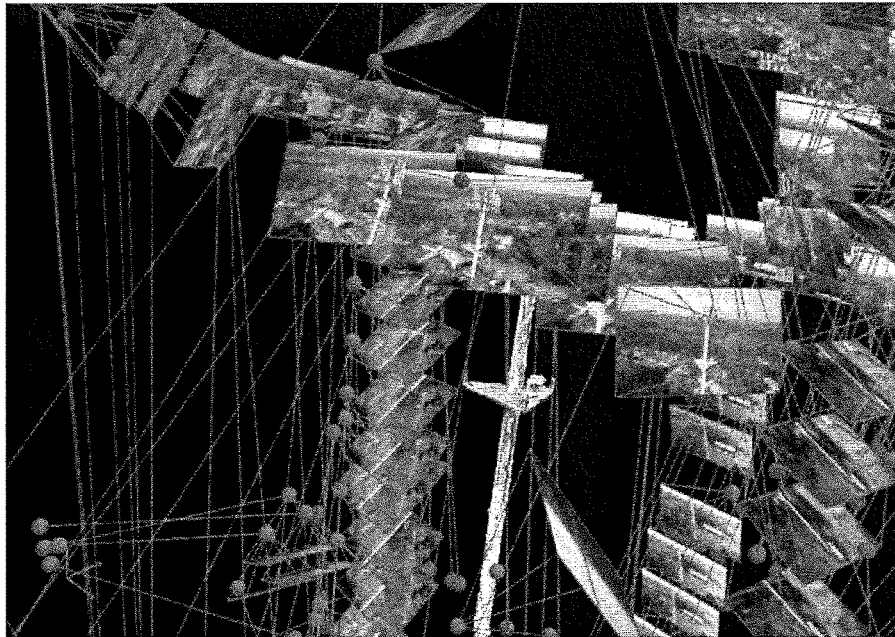


FIG. 17

Number of Images Visible In: 128
Computed Position [ft]: 1982150.49, 1254035.79, 735.07

Images

Image Size Zoom Level

E16A704.JPG	E16A704.JPG	E16A6969.JPG
E16A6970.JPG	E16A6965.JPG	E16A6967.JPG
E16A6968.JPG	E16A6966.JPG	E16A6968.JPG



FIG. 18

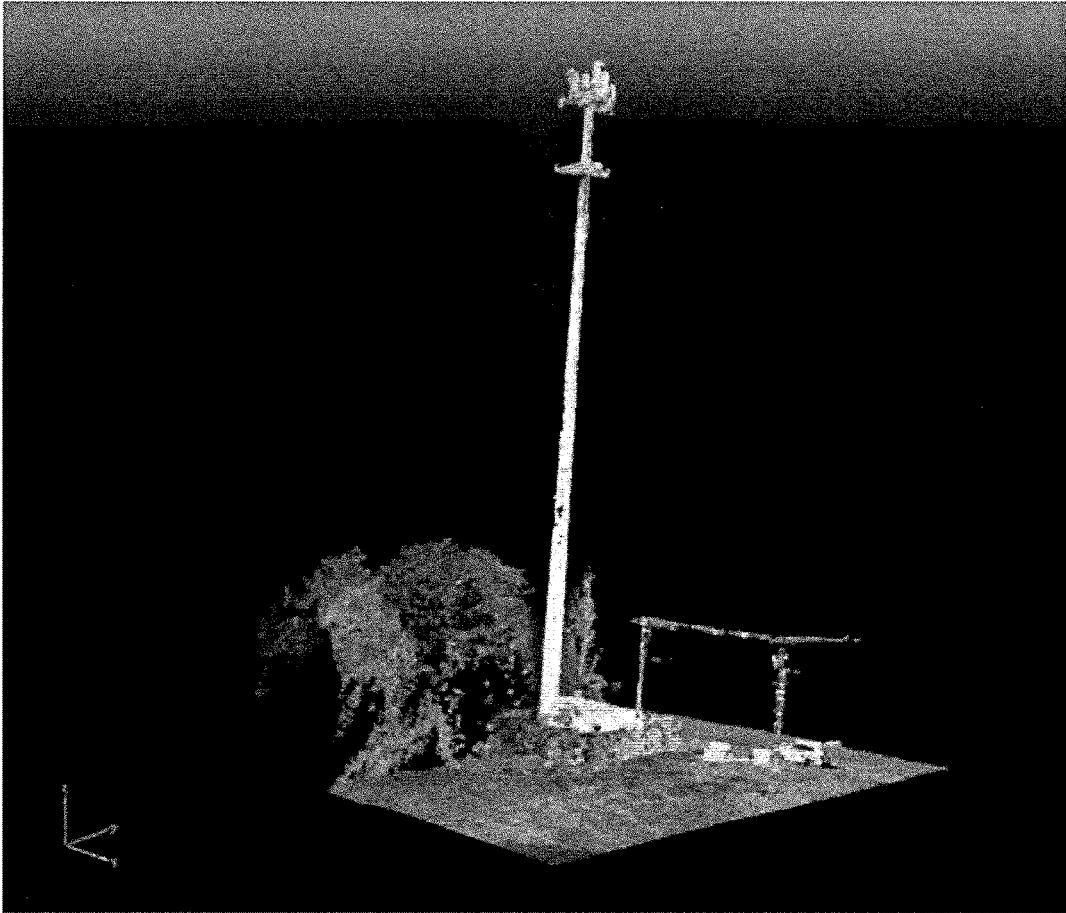


FIG. 19

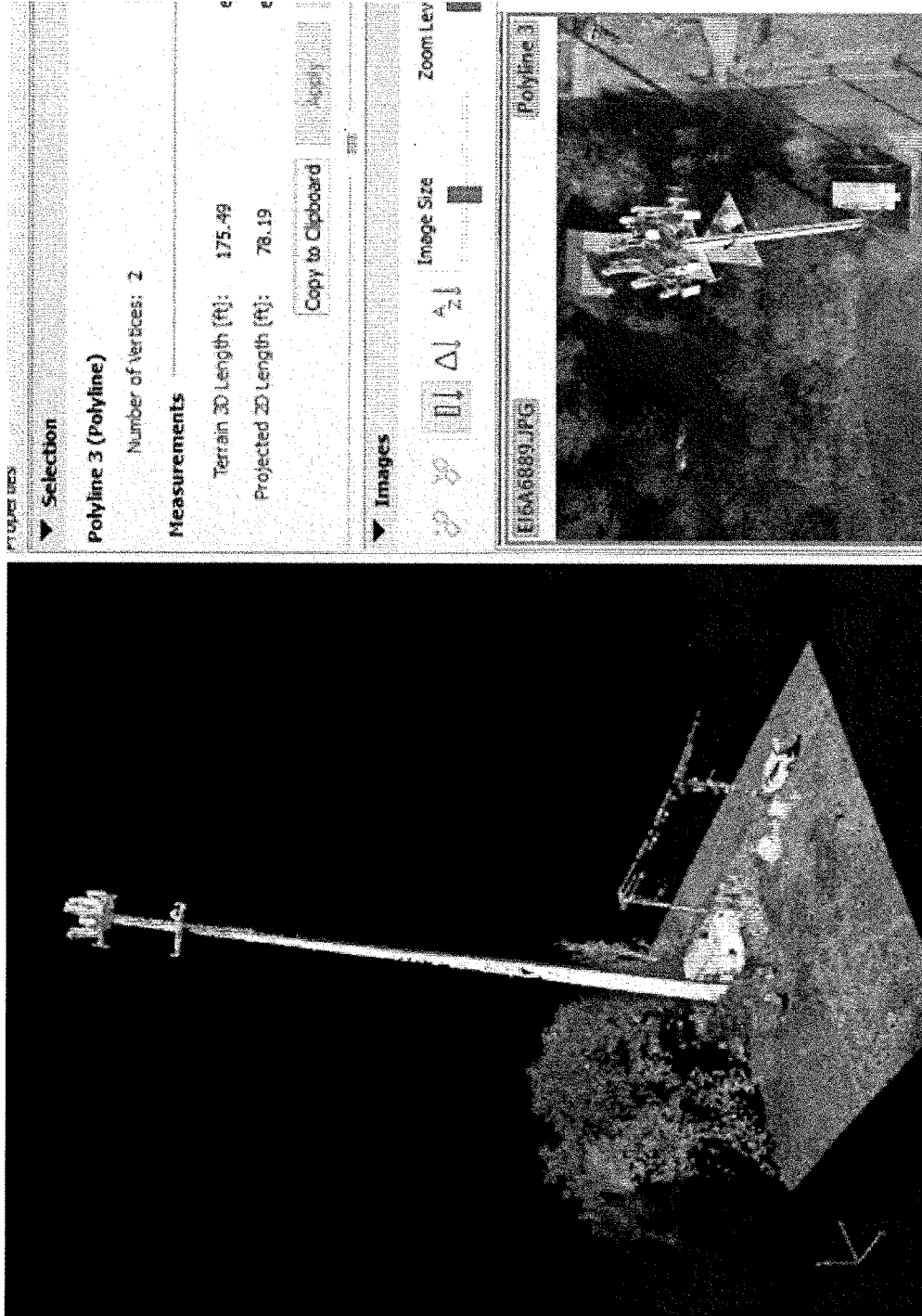


FIG. 20



FIG. 21



FIG. 22



FIG. 23

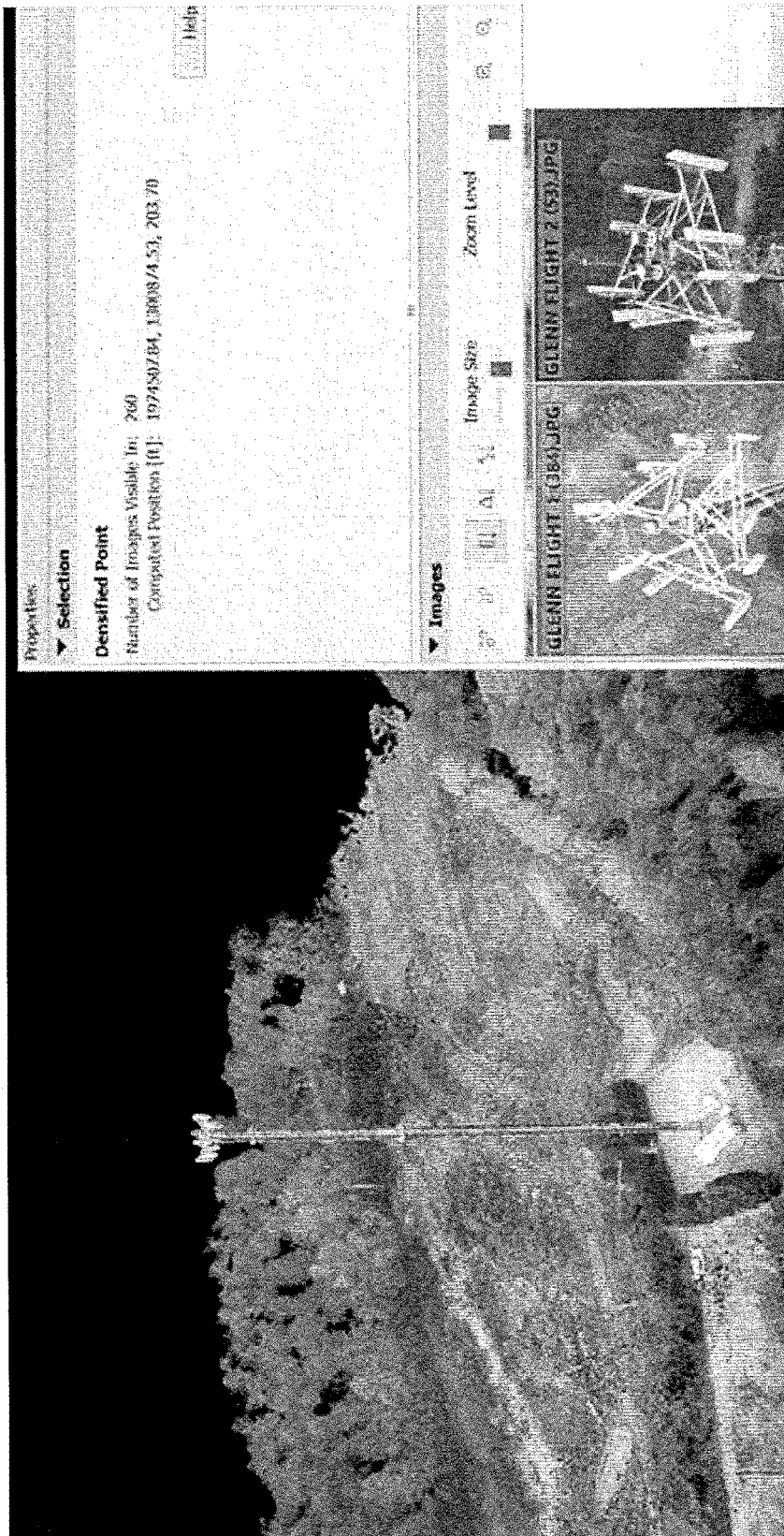


FIG. 24

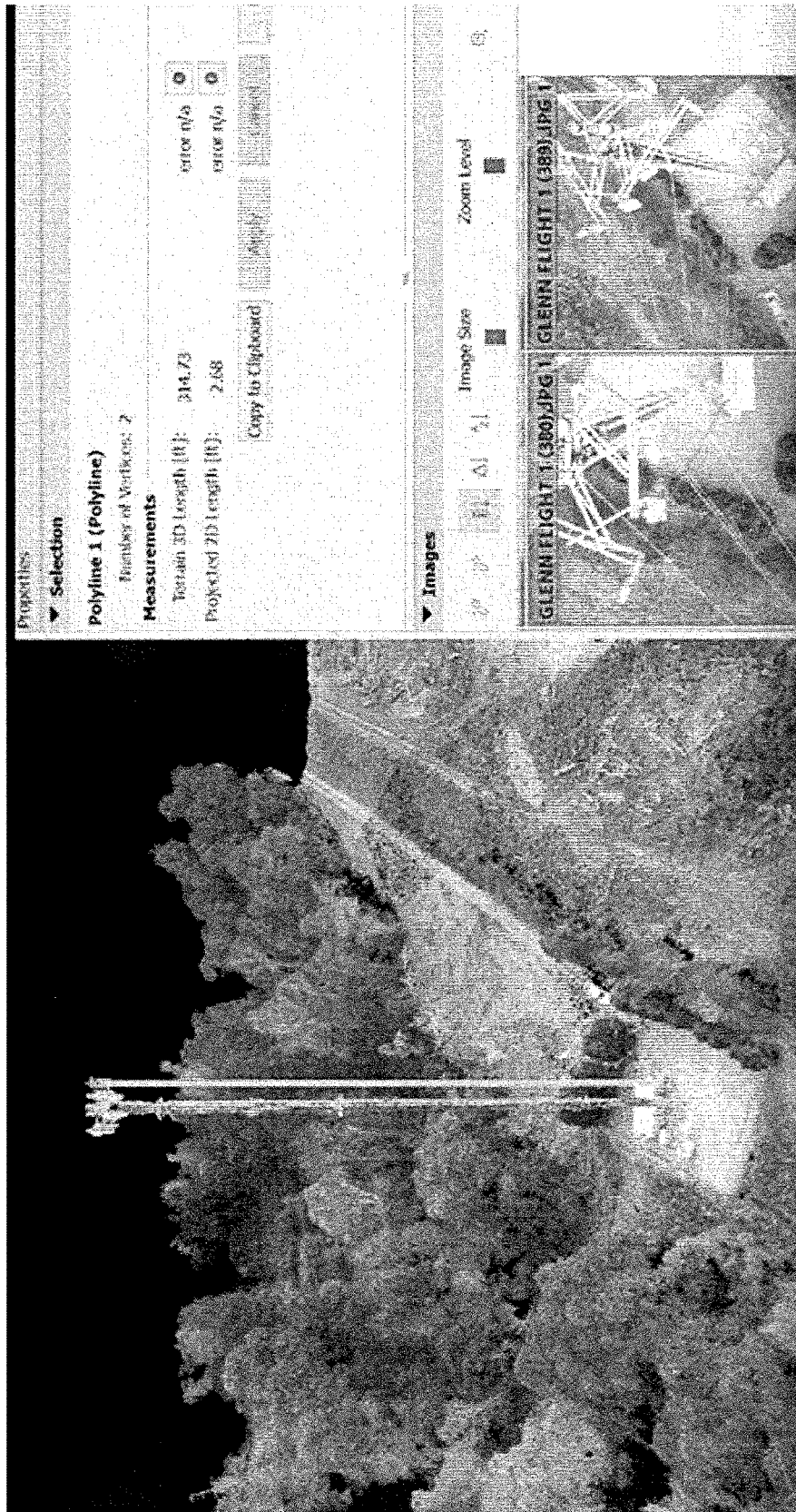
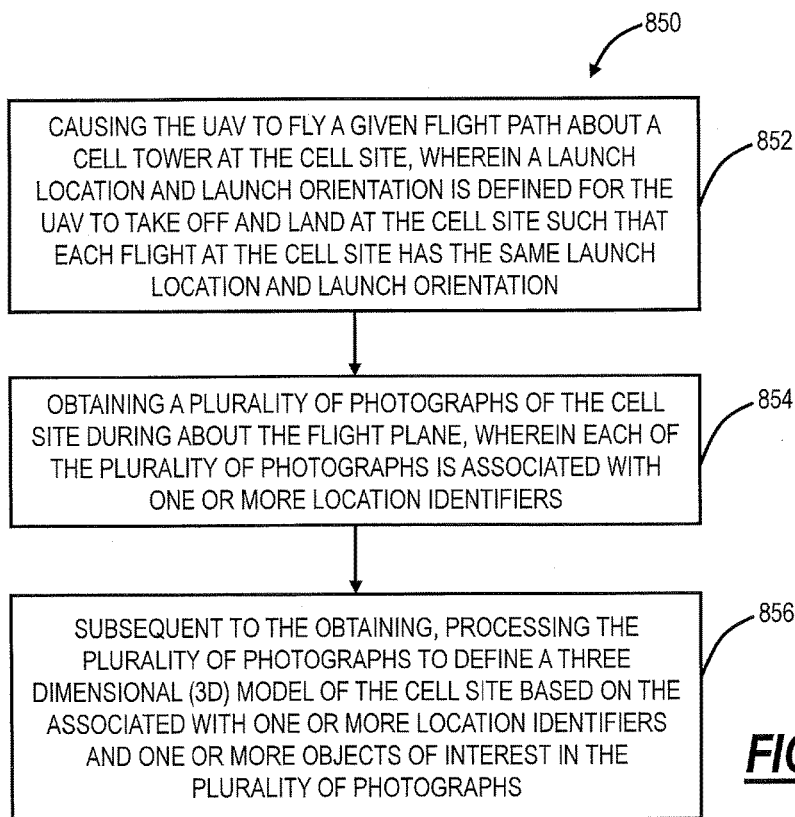


FIG. 25



FIG. 26



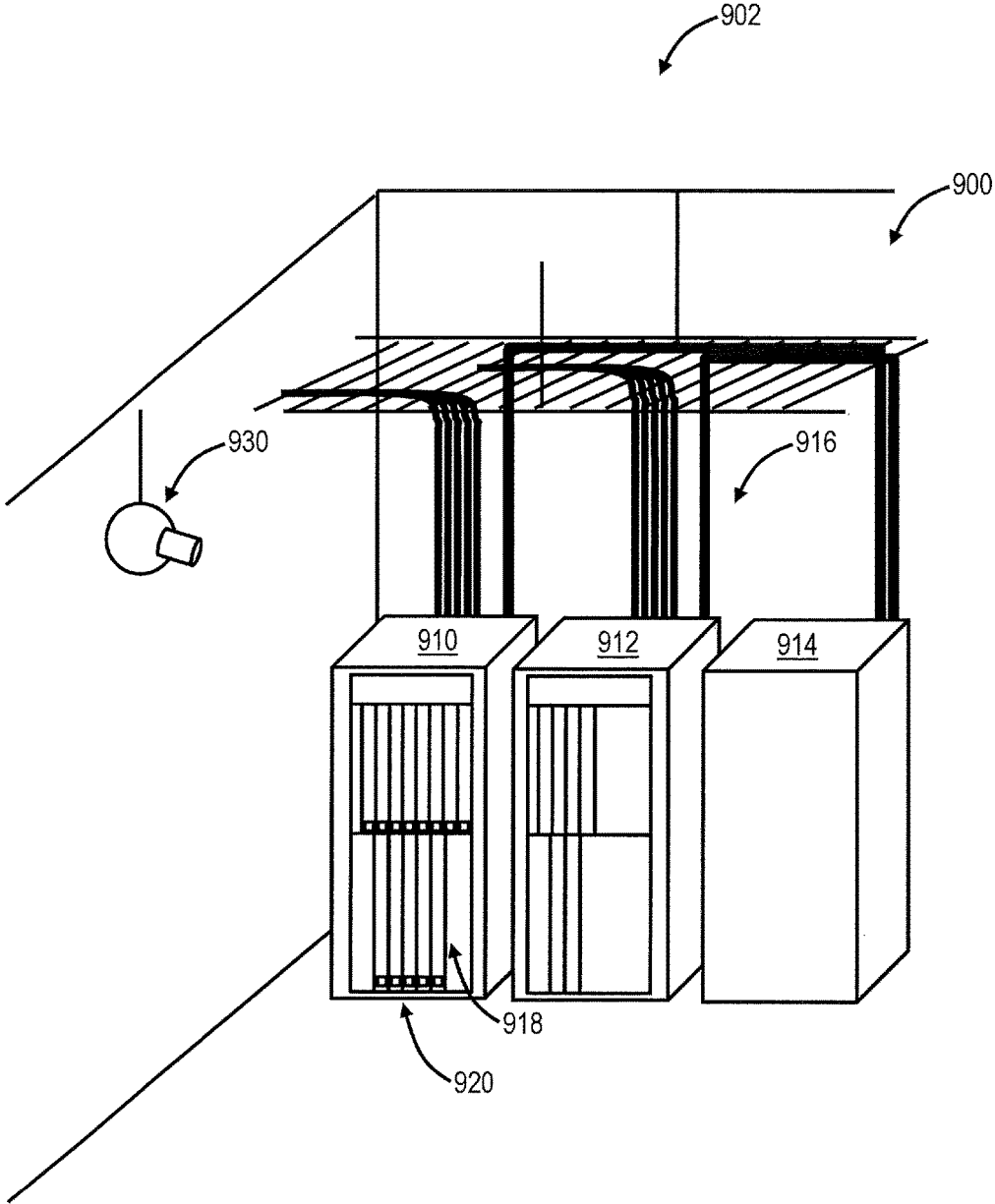


FIG. 28

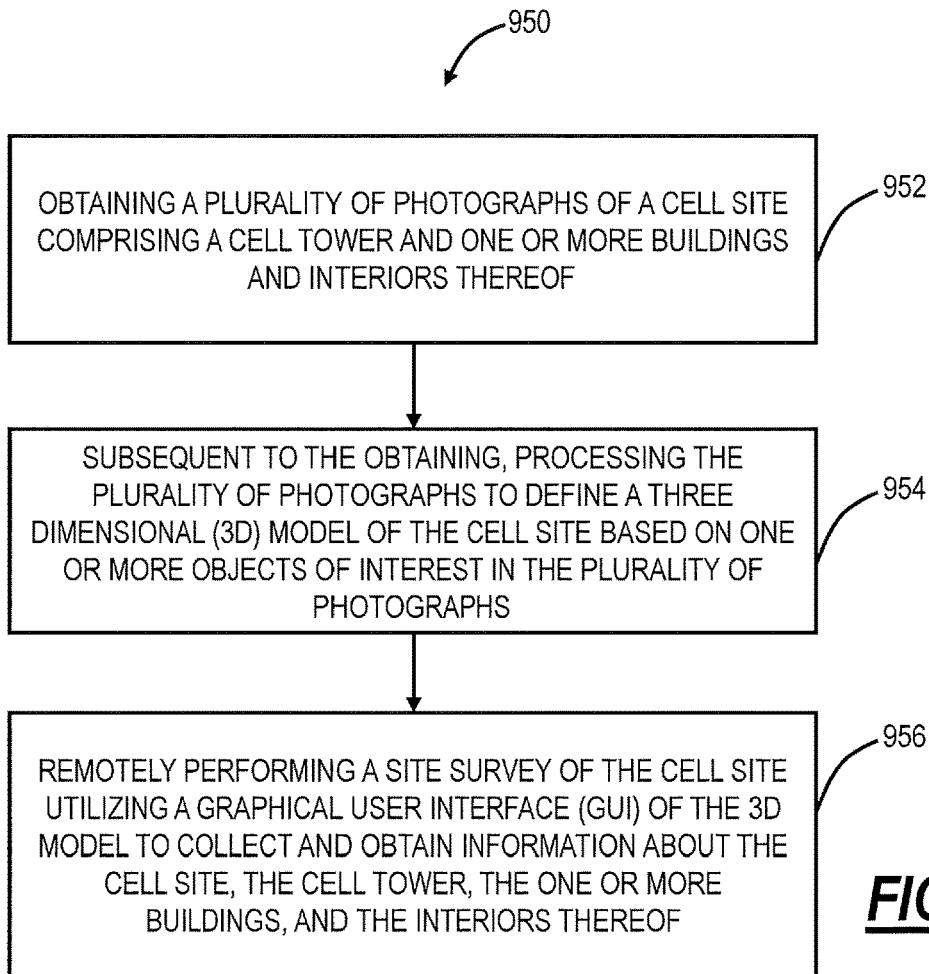


FIG. 29

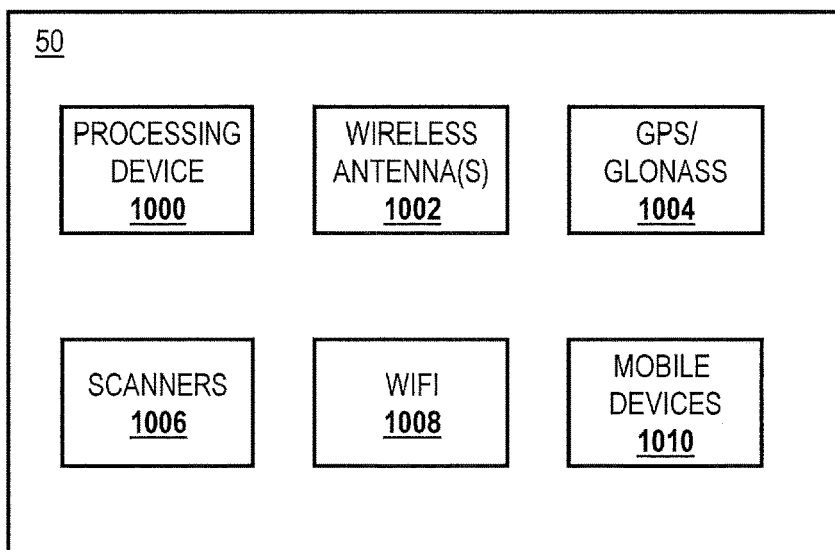


FIG. 30

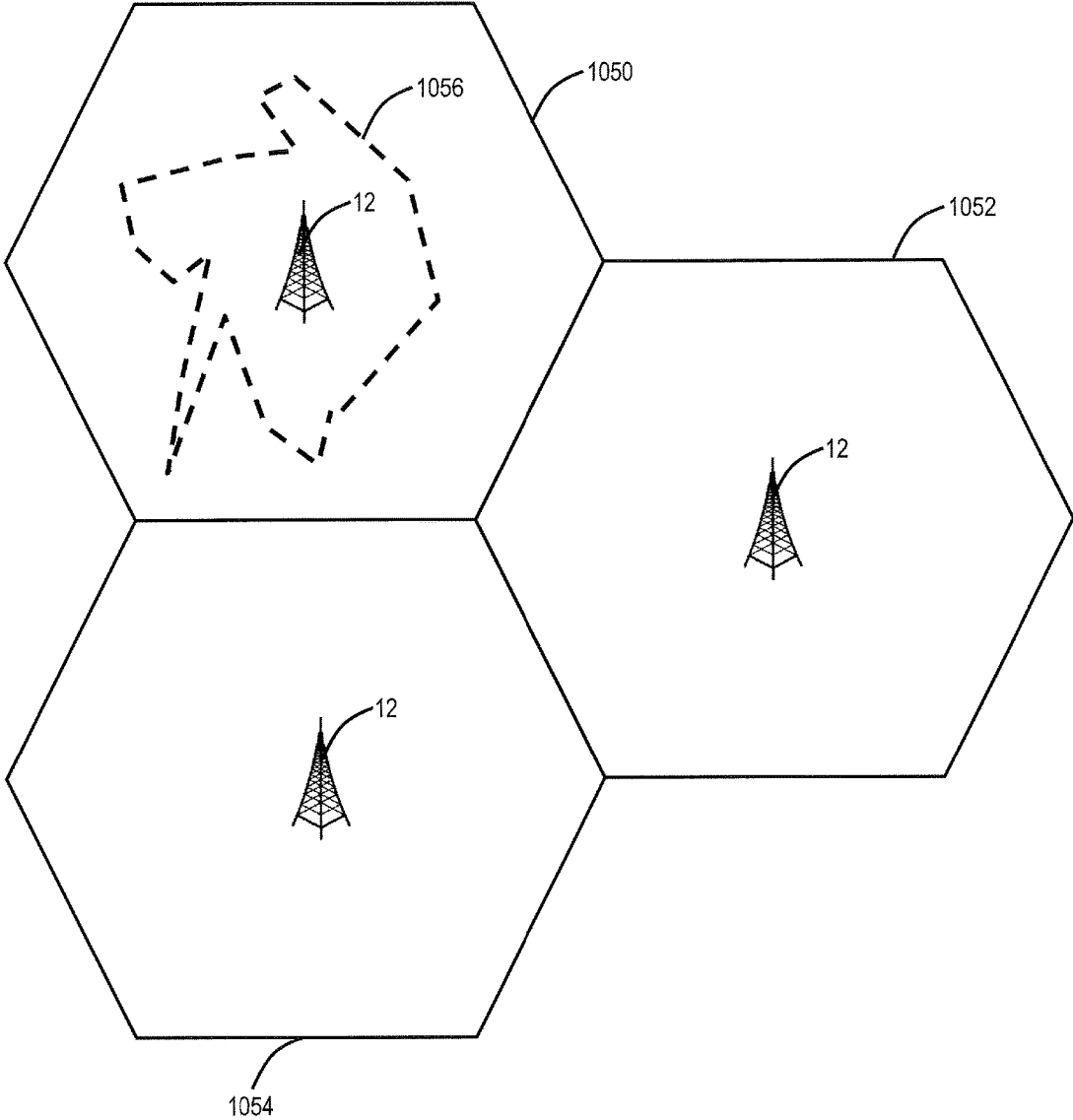


FIG. 31

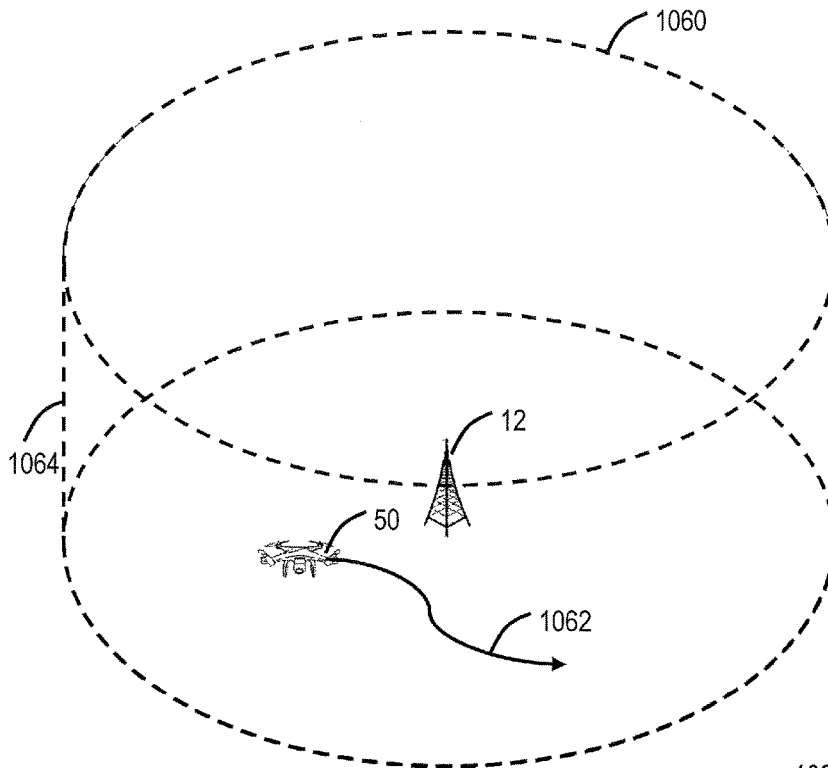


FIG. 32

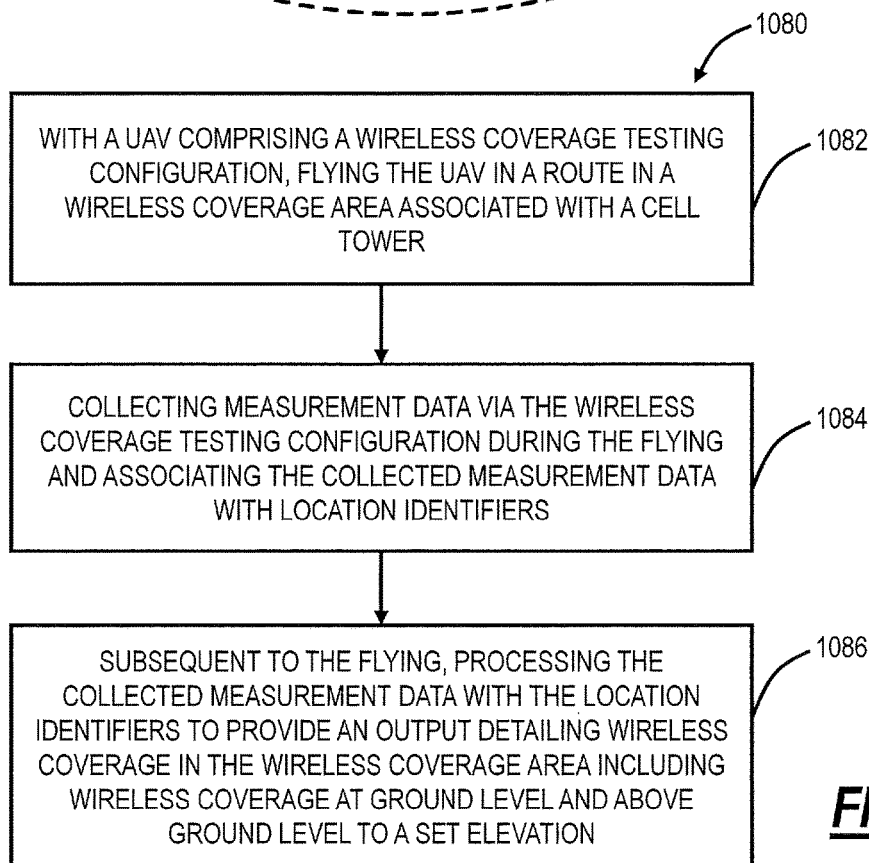


FIG. 33

FIG. 34

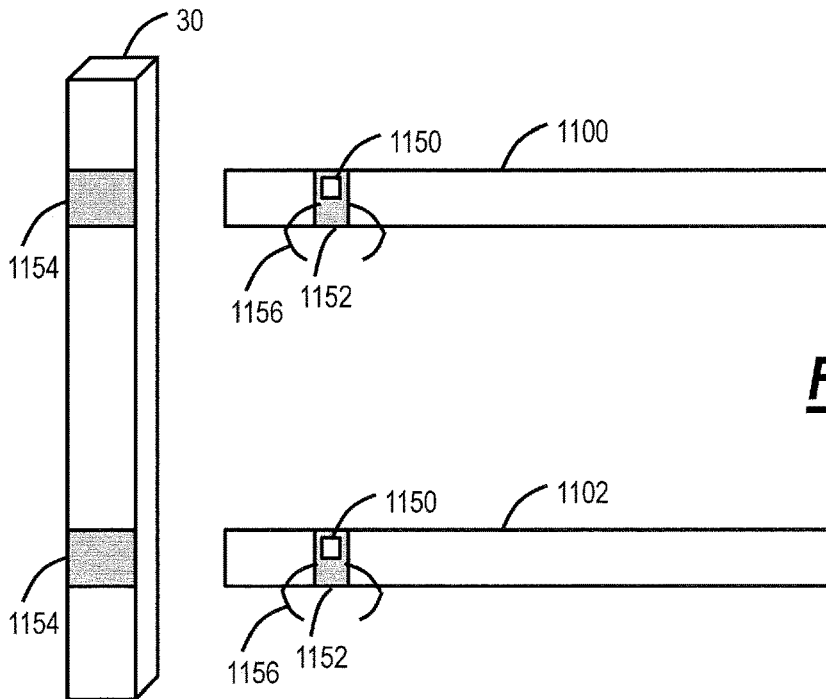
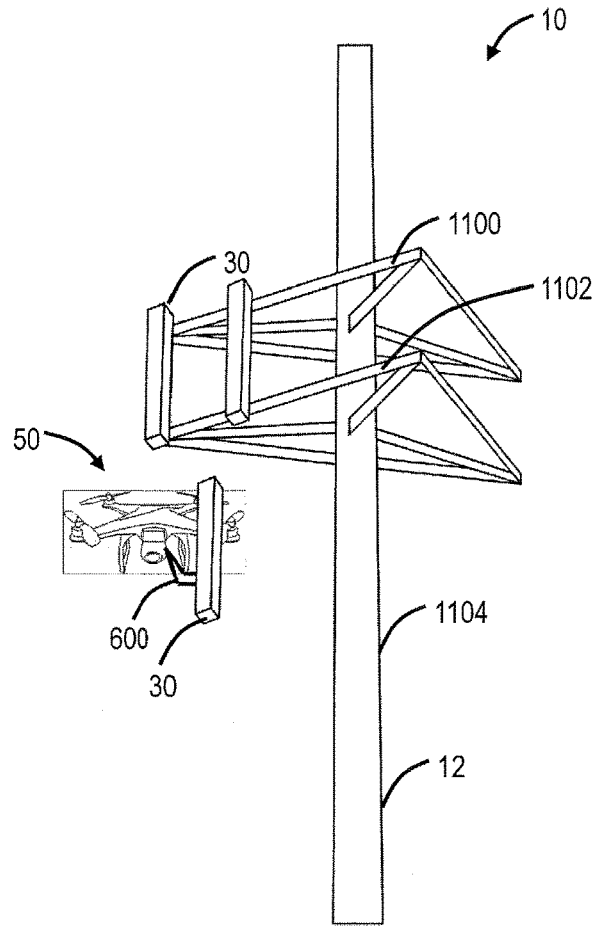


FIG. 35

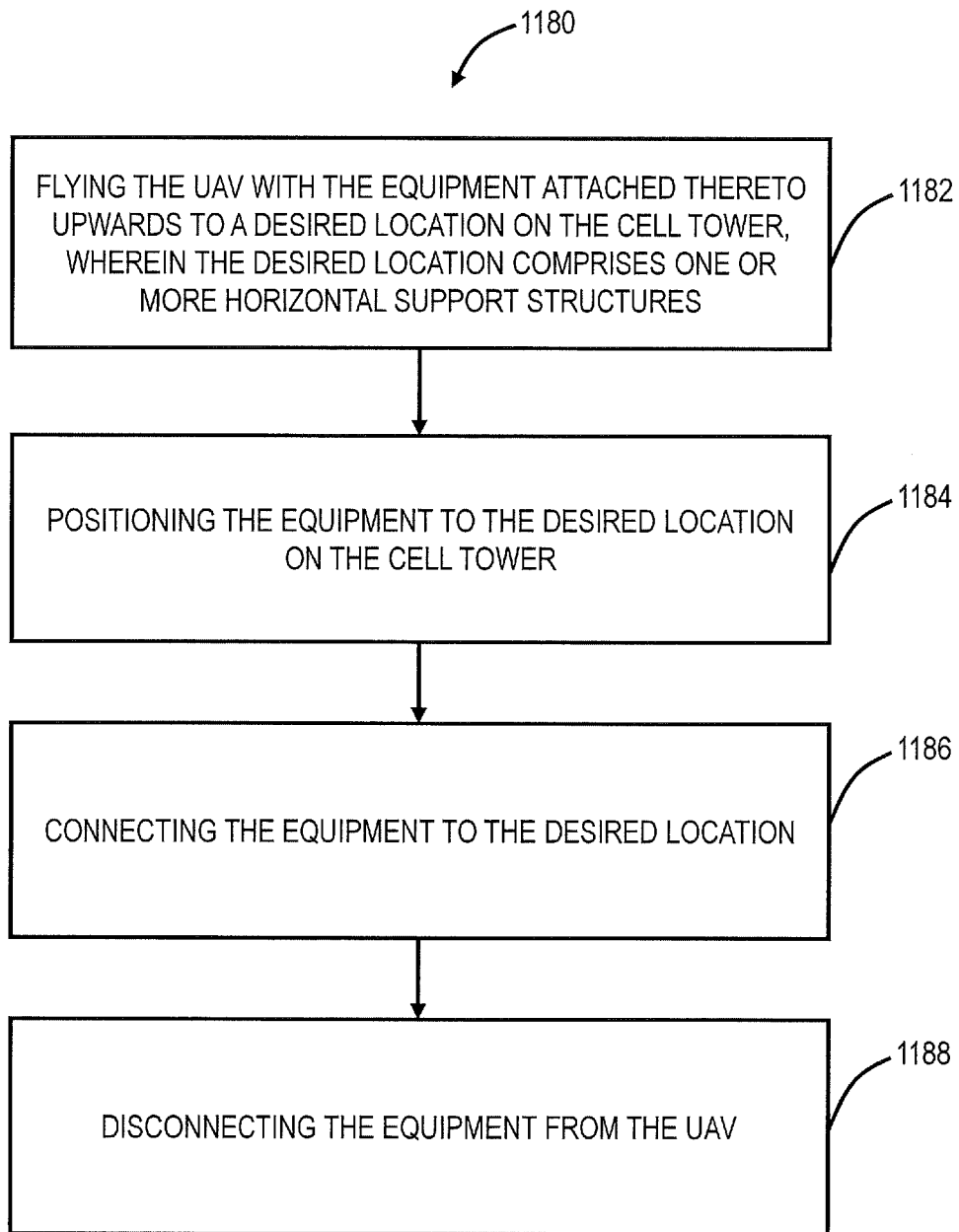
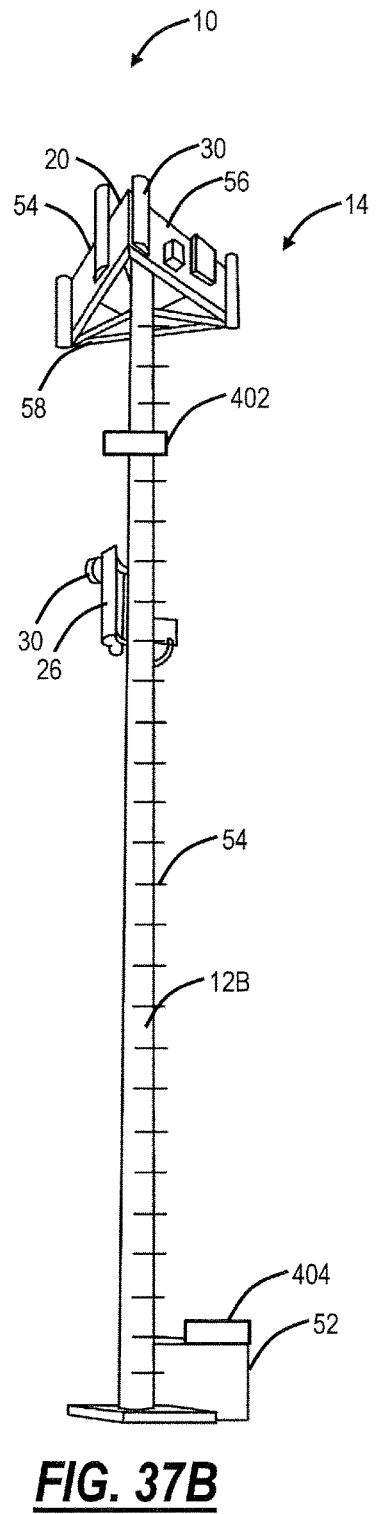
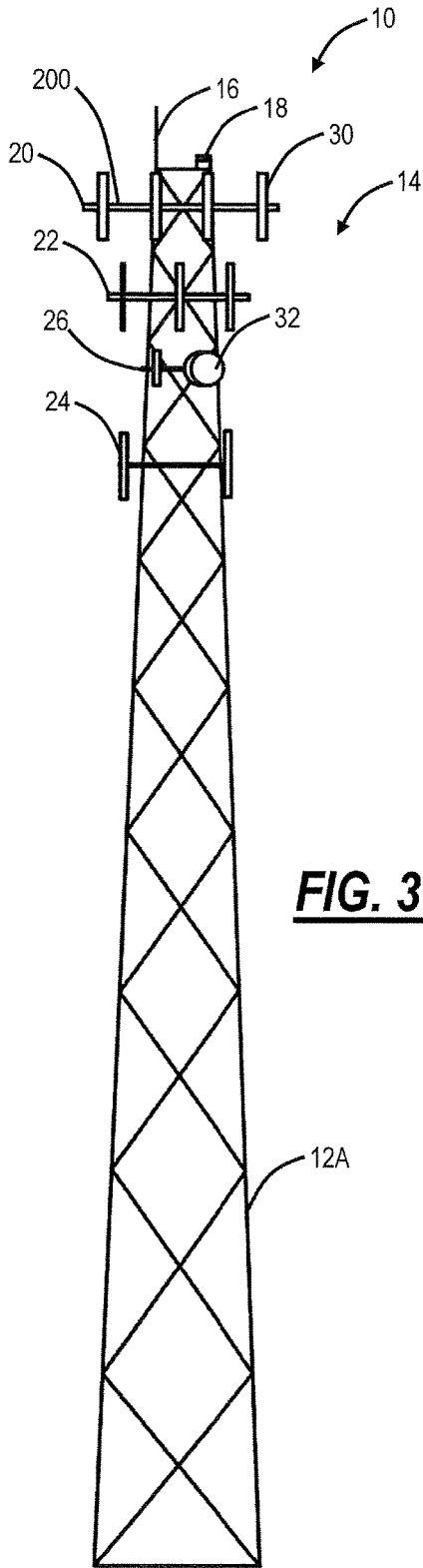


FIG. 36



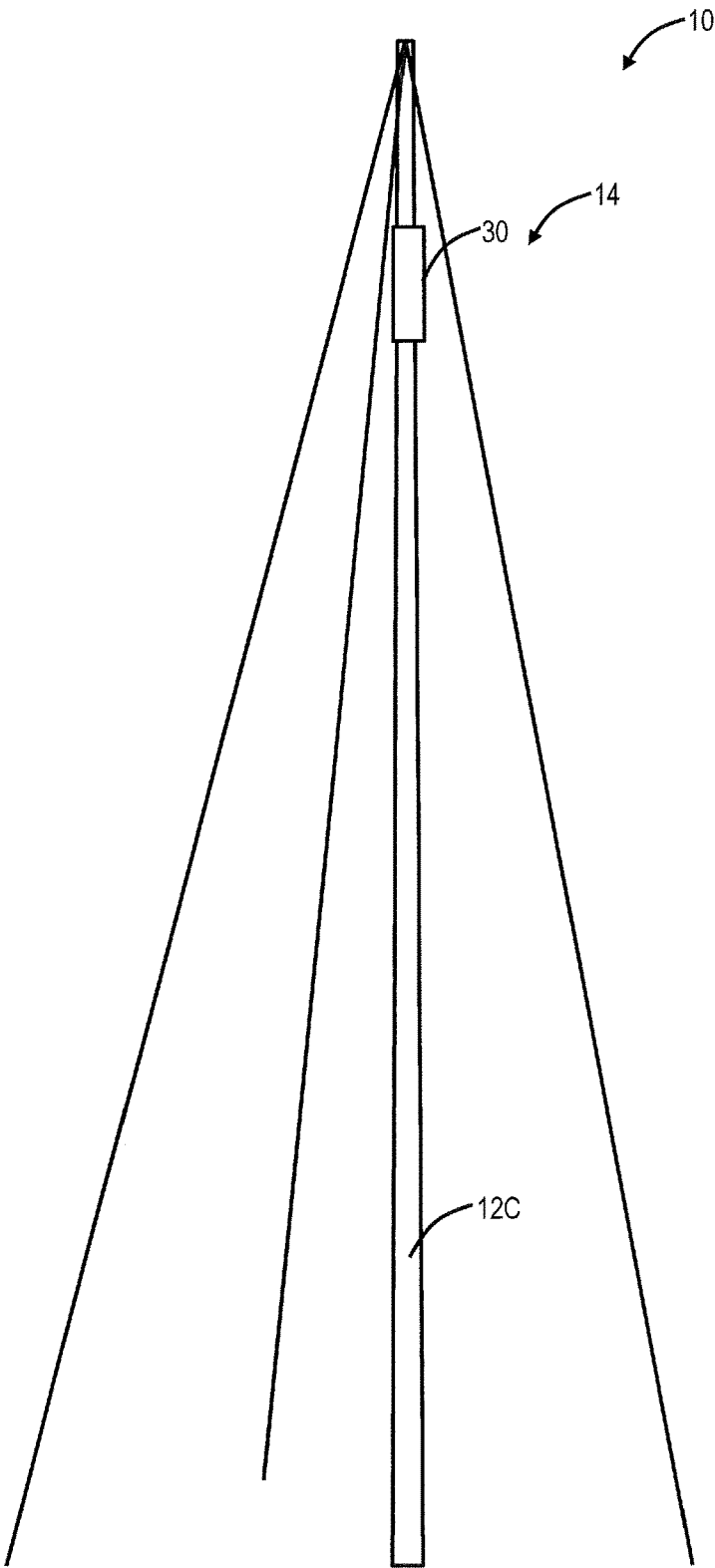


FIG. 37C

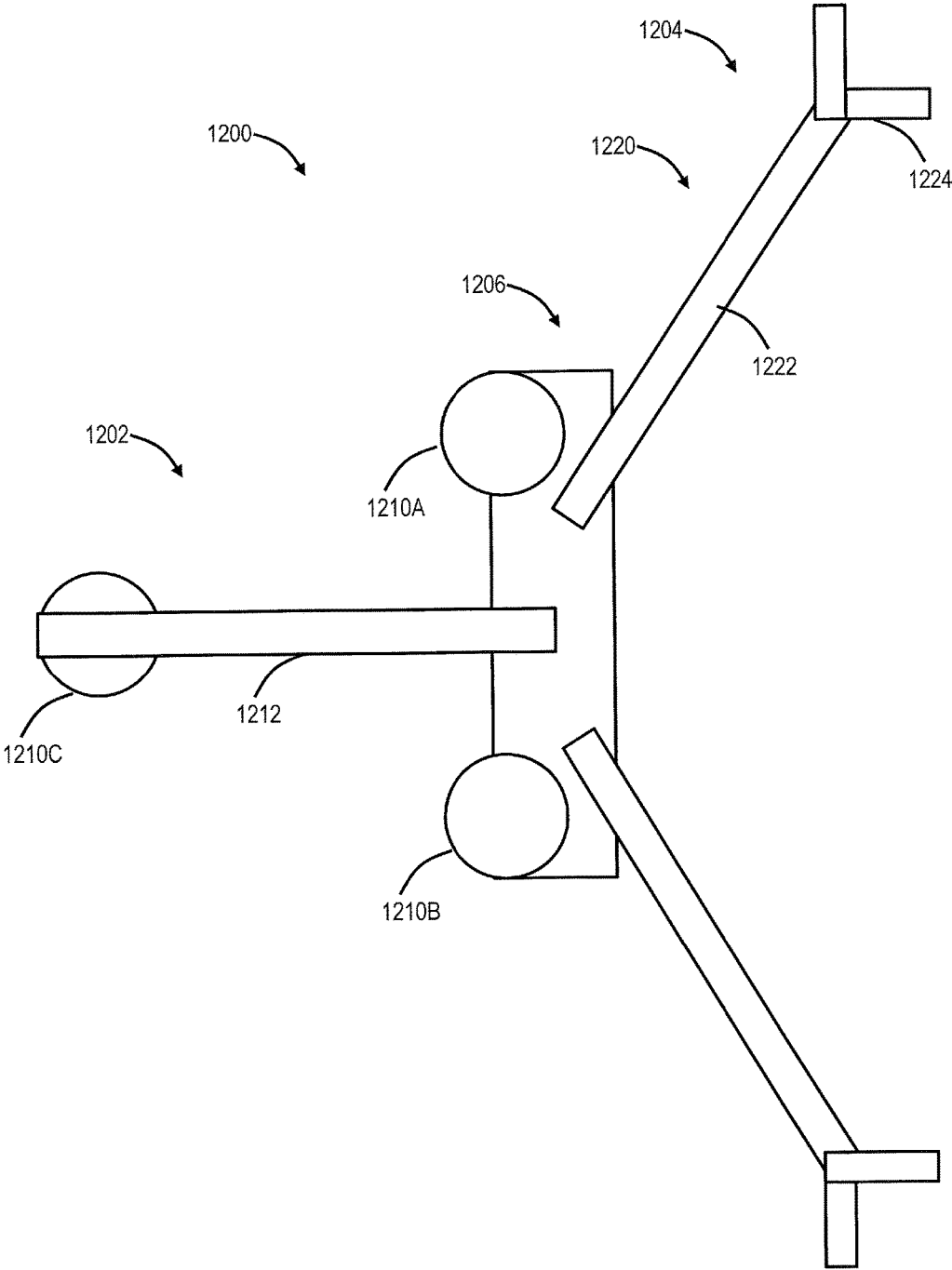


FIG. 38

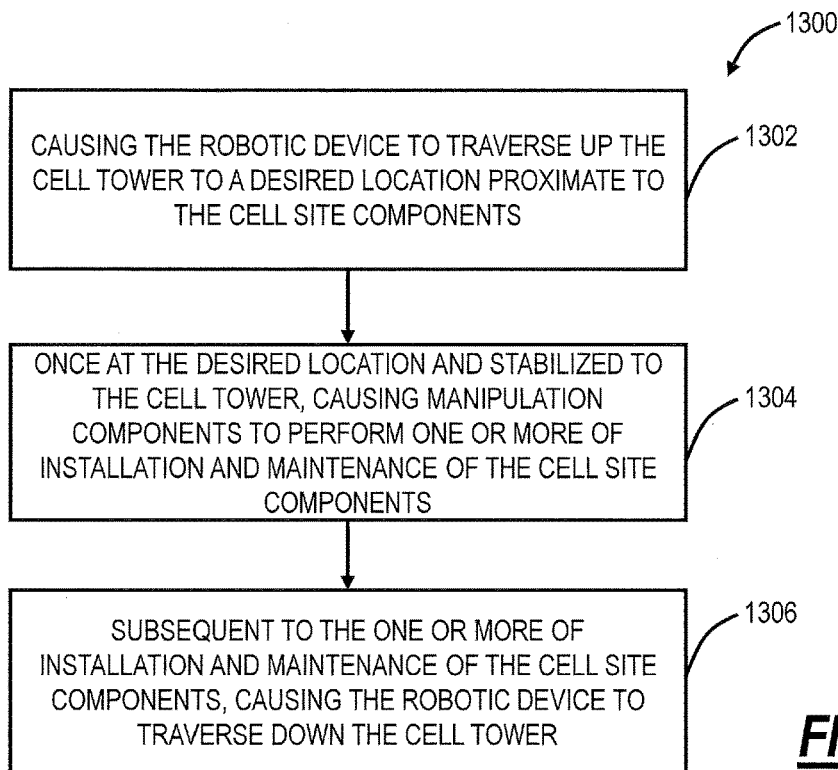


FIG. 39

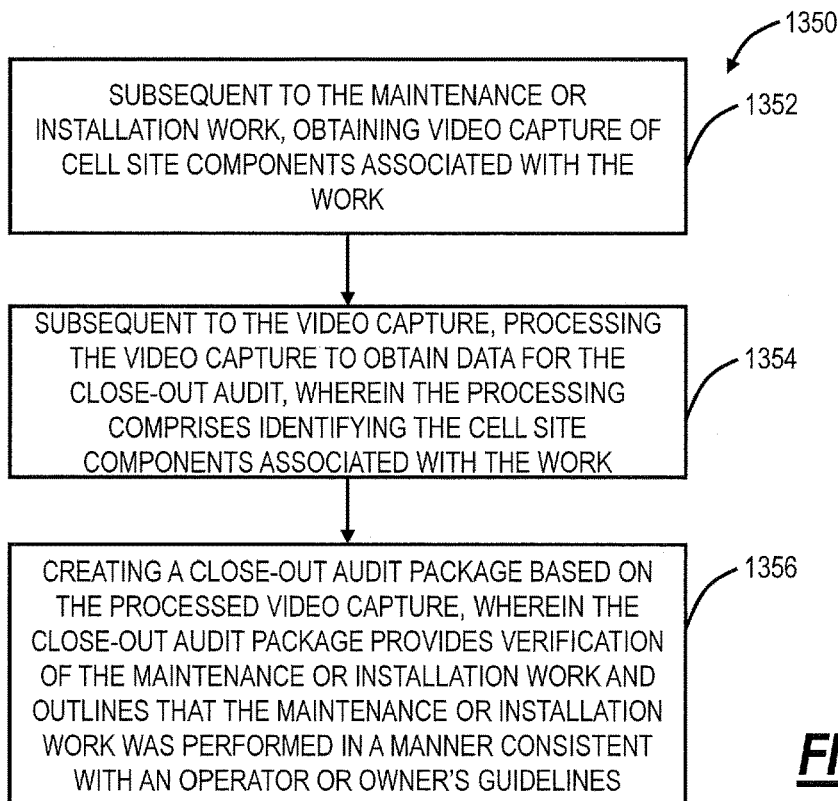


FIG. 40

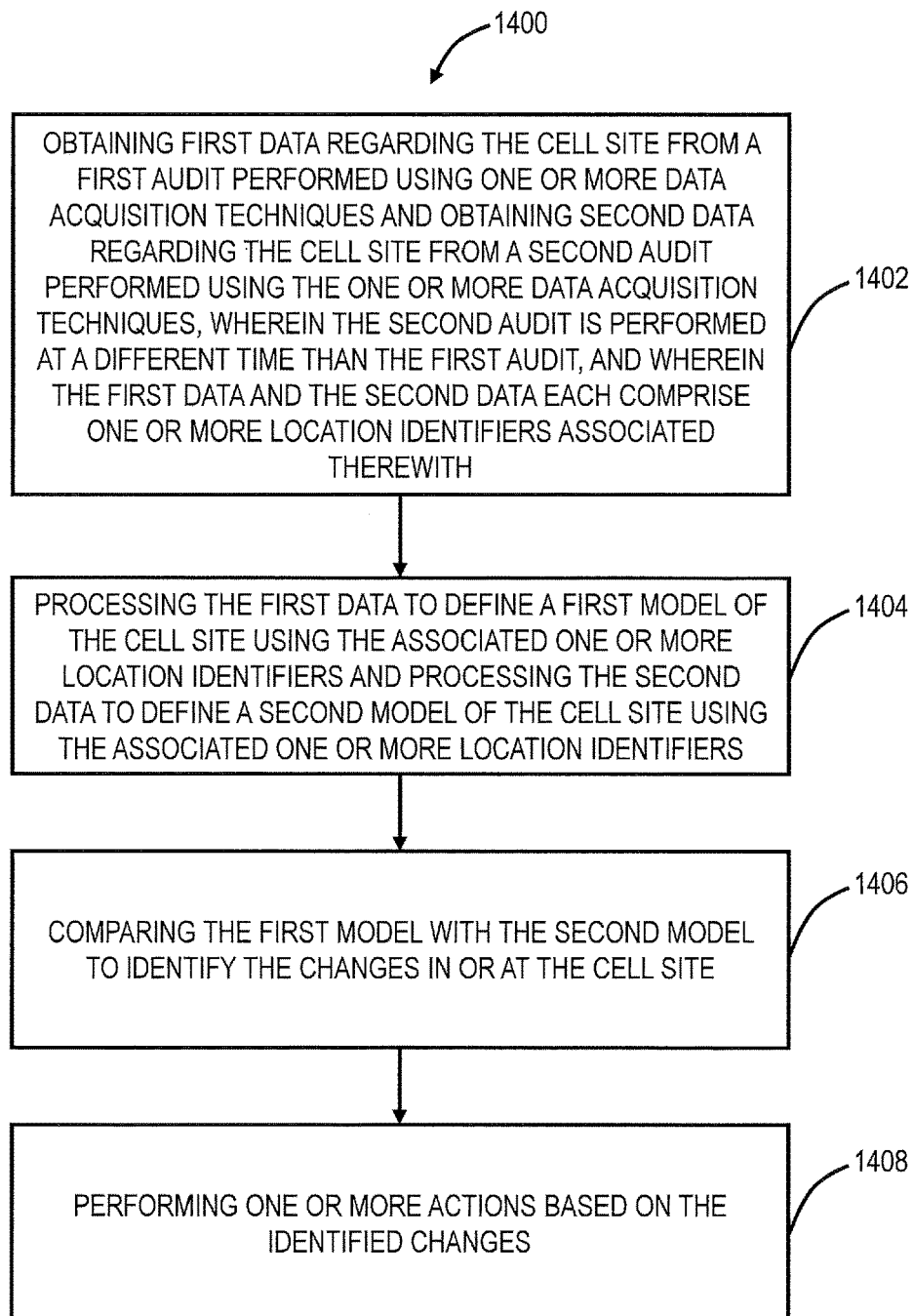
**FIG. 41**

FIG. 42

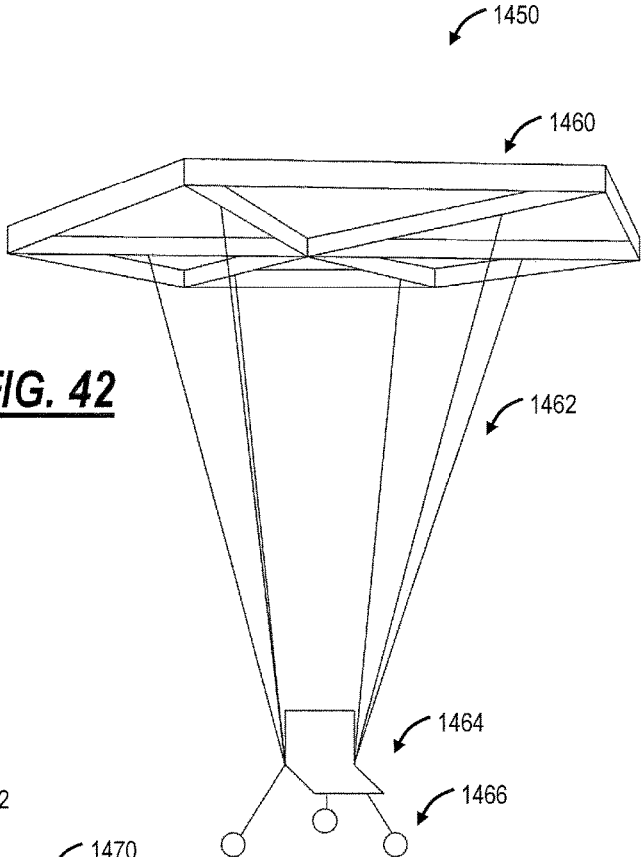
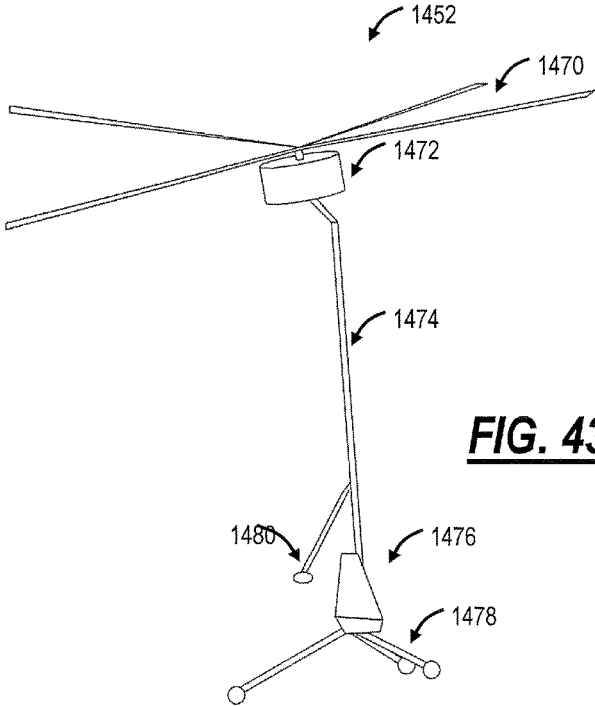
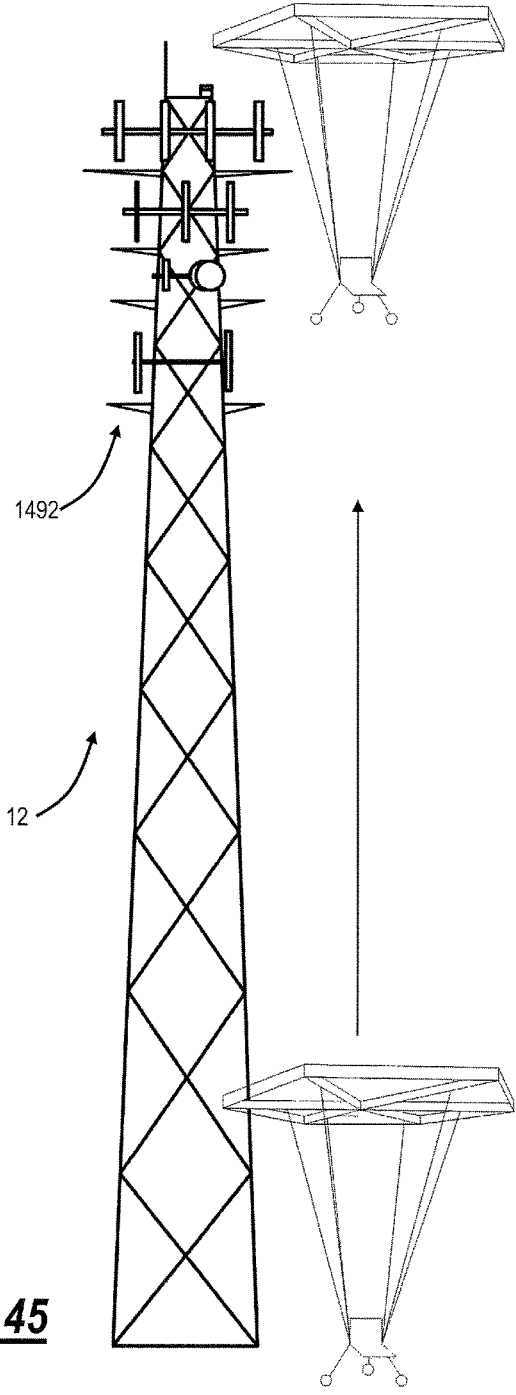
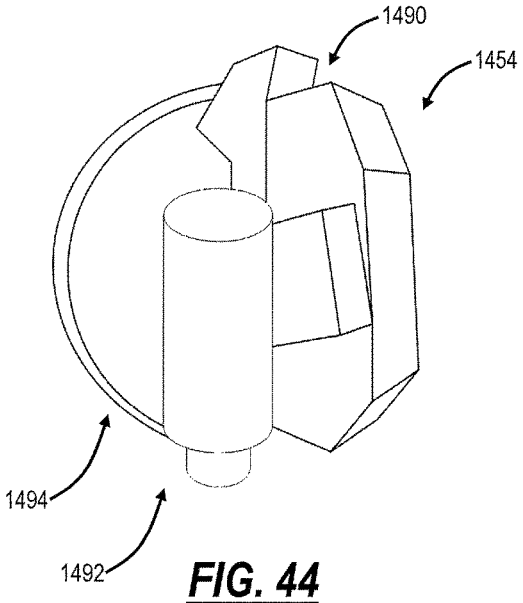


FIG. 43





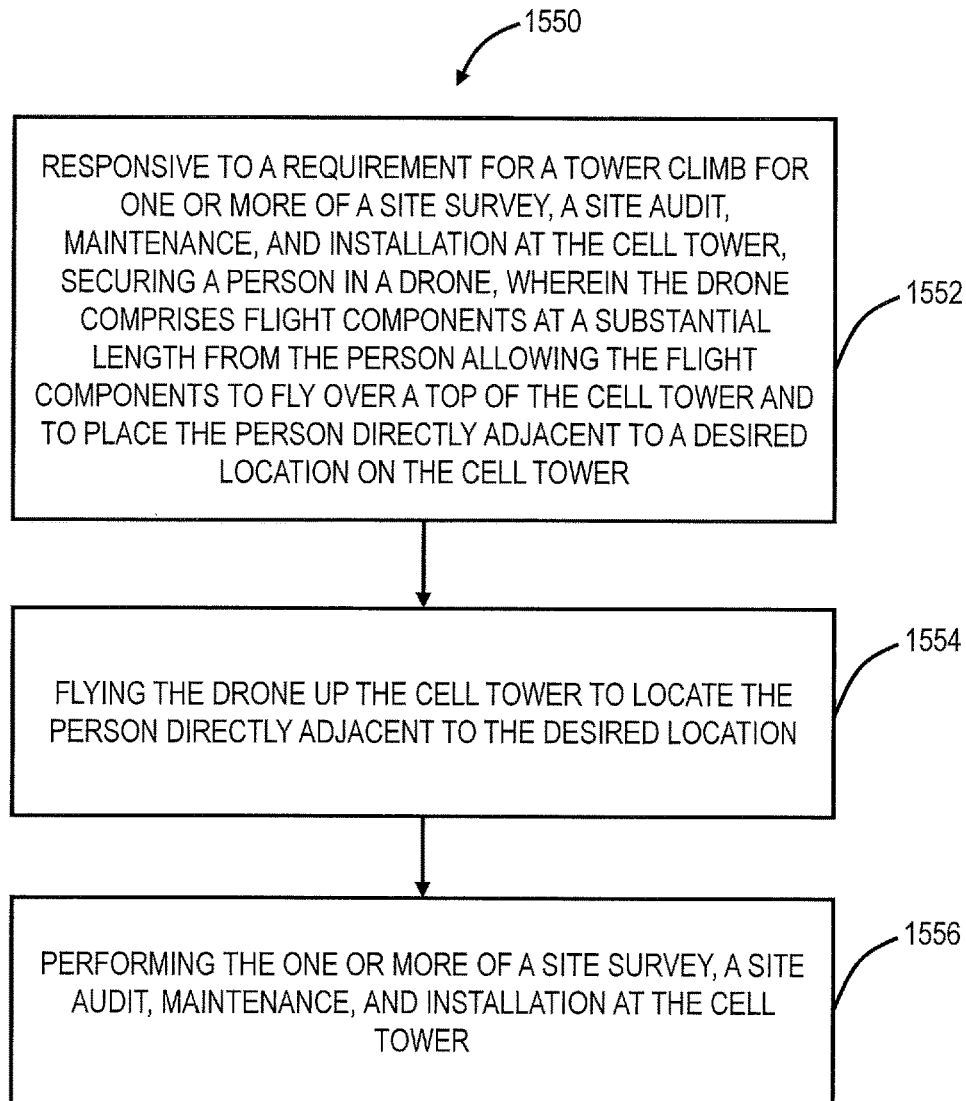


FIG. 46

FIG. 47A

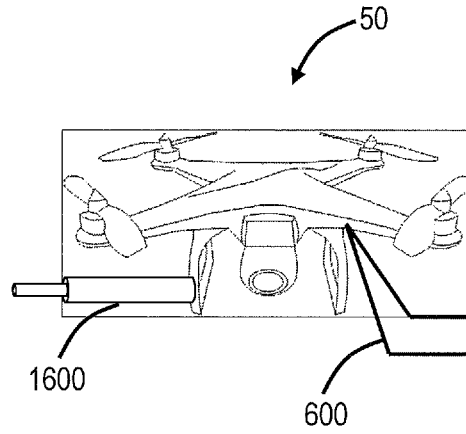


FIG. 47B

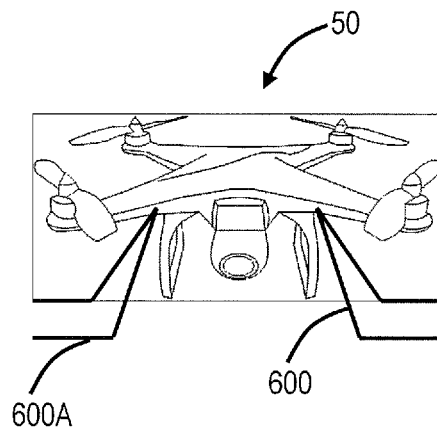
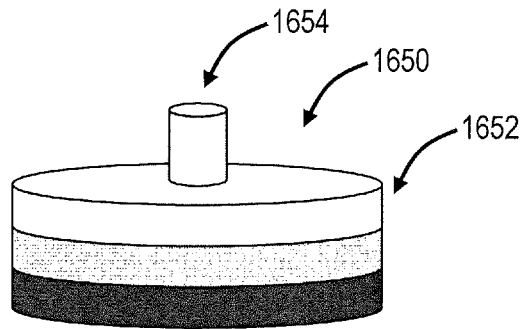


FIG. 47C



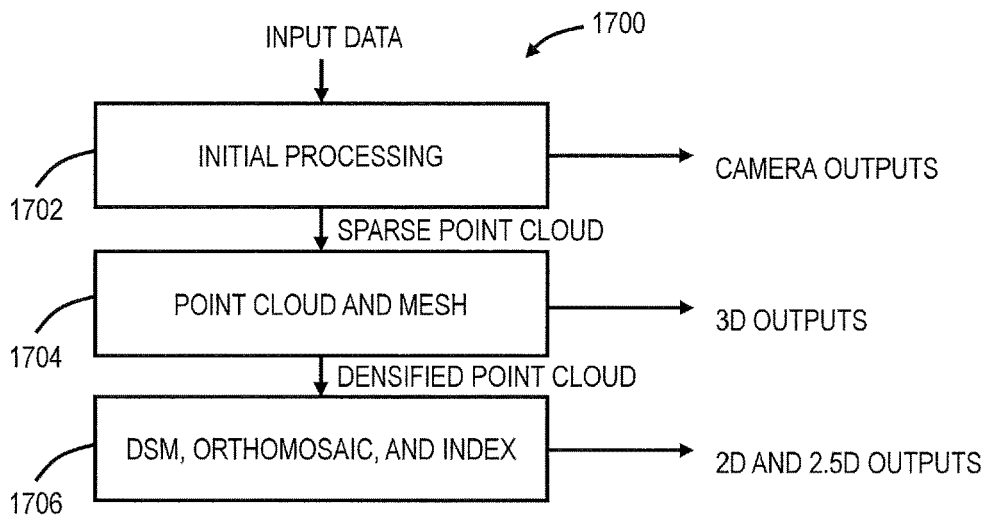


FIG. 48

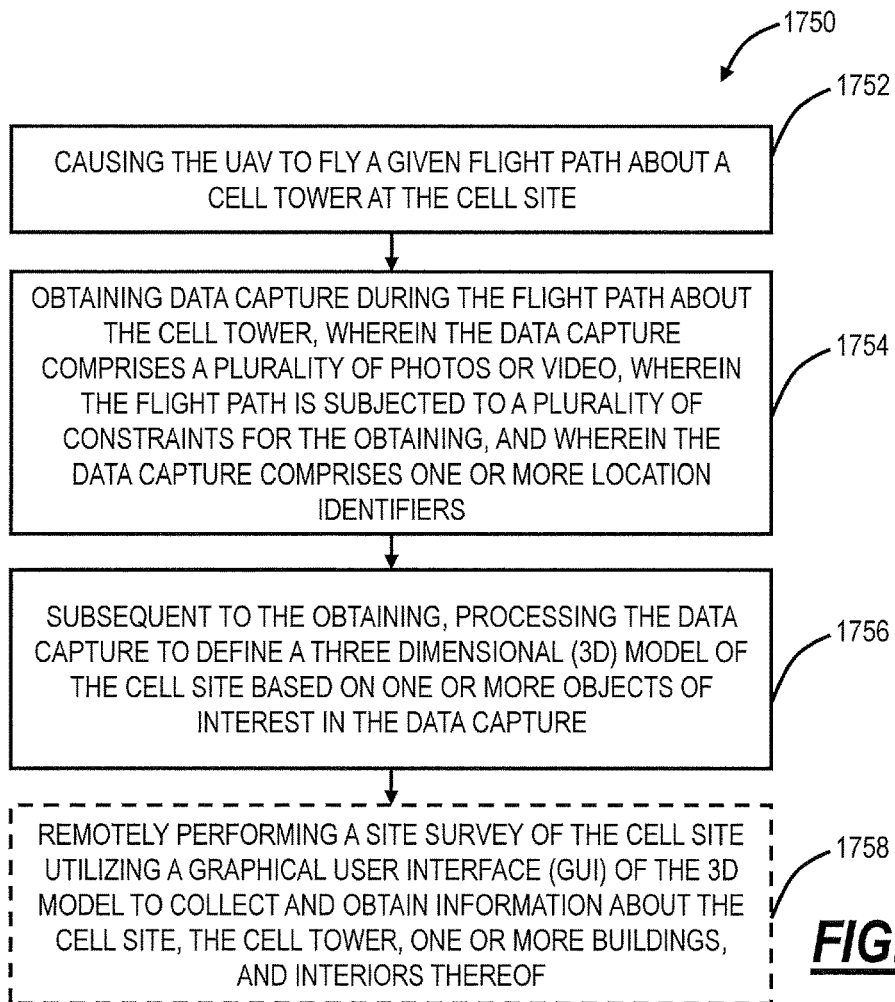


FIG. 49

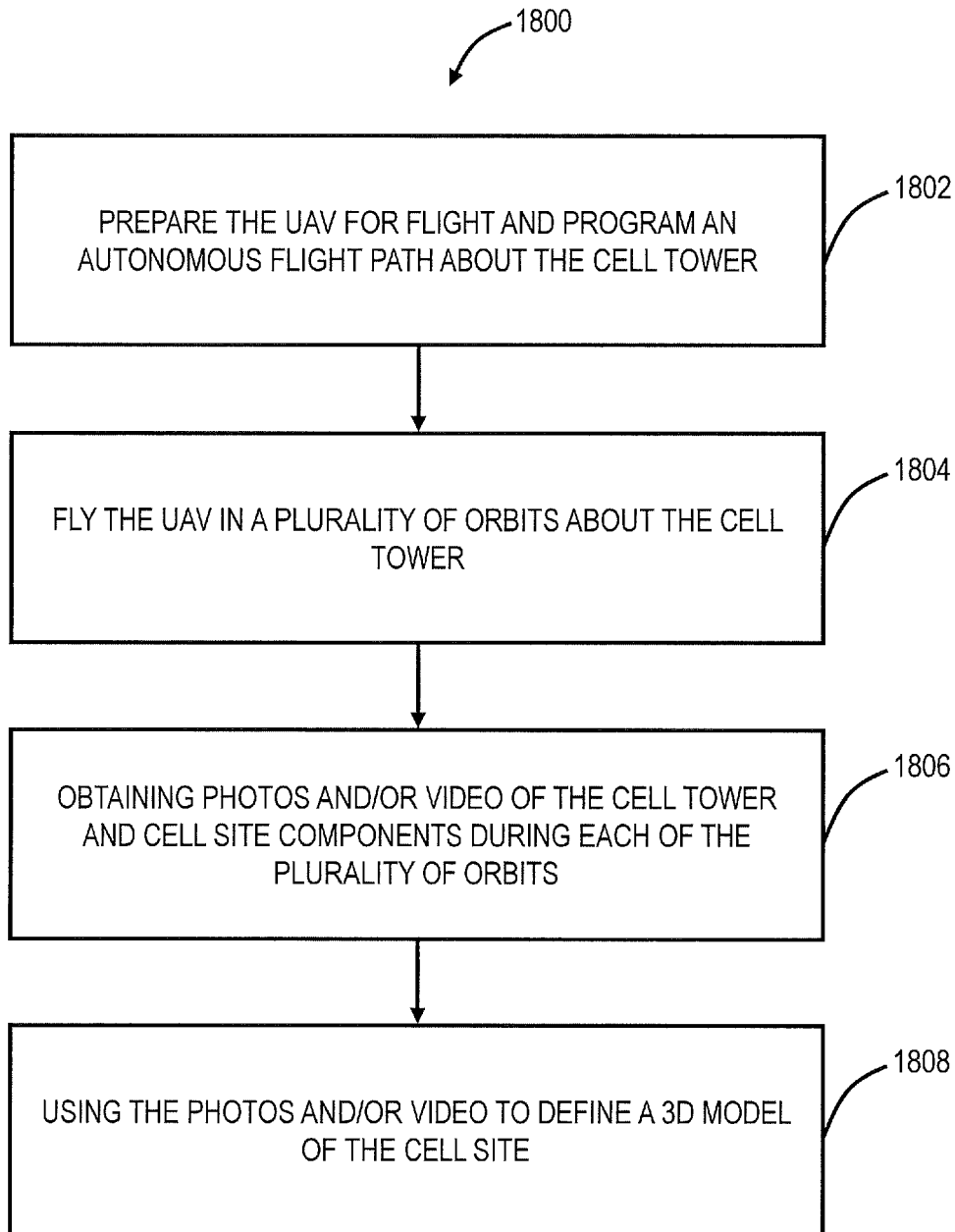


FIG. 50

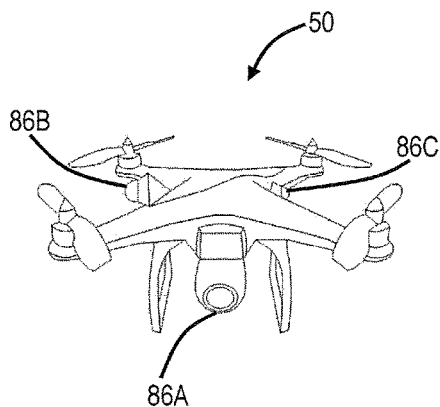


FIG. 51A

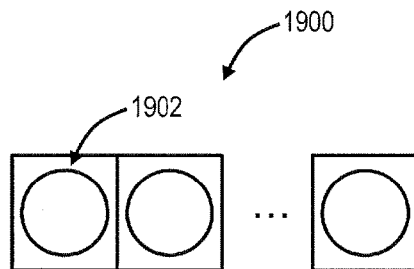


FIG. 51B

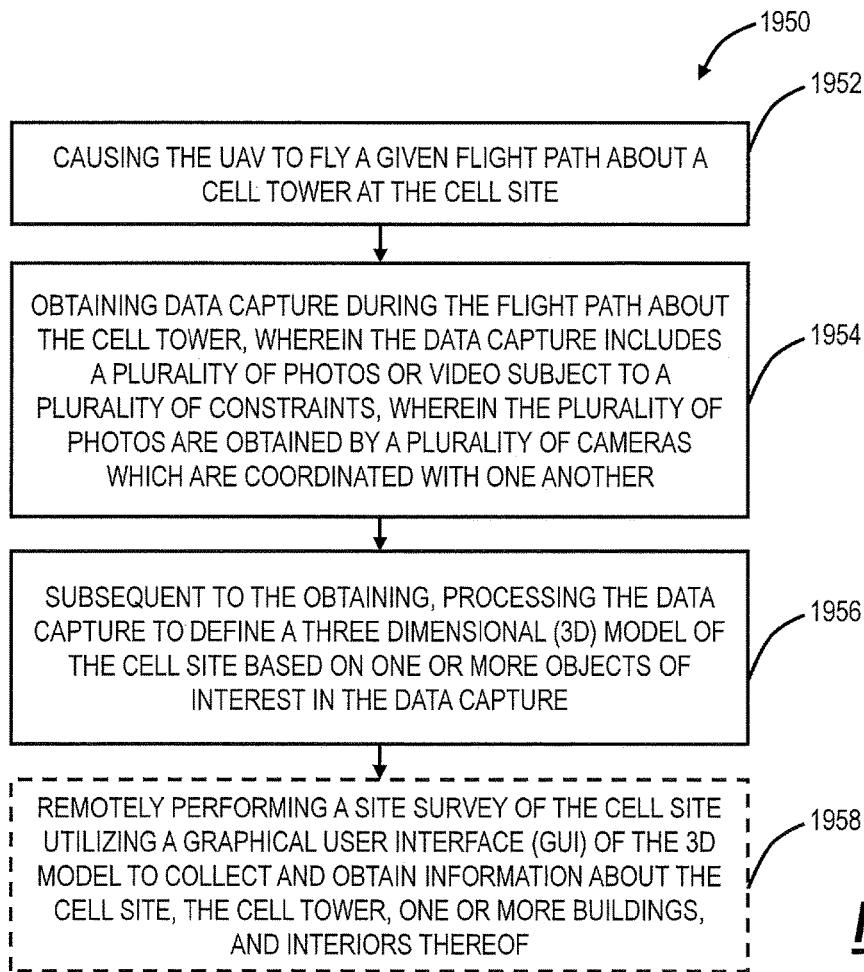


FIG. 52

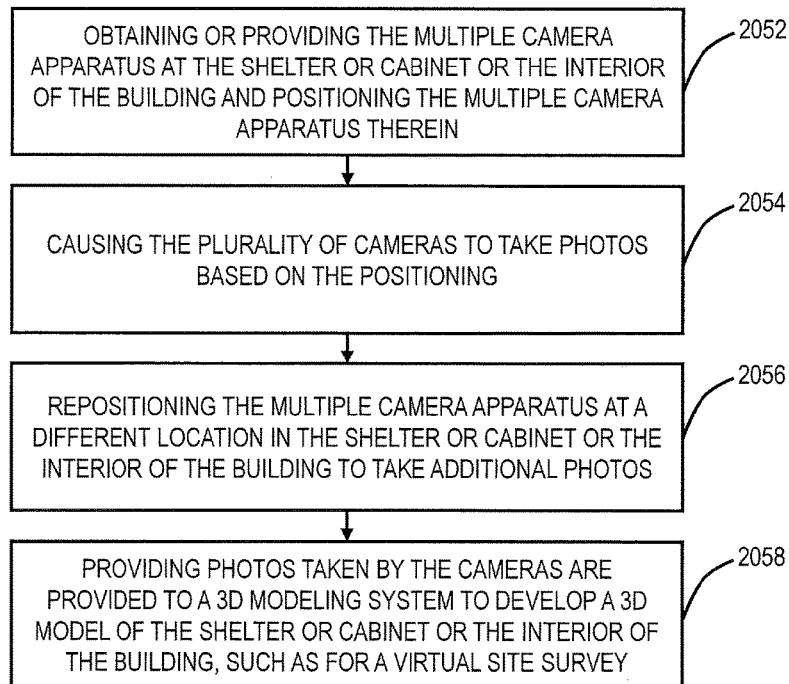
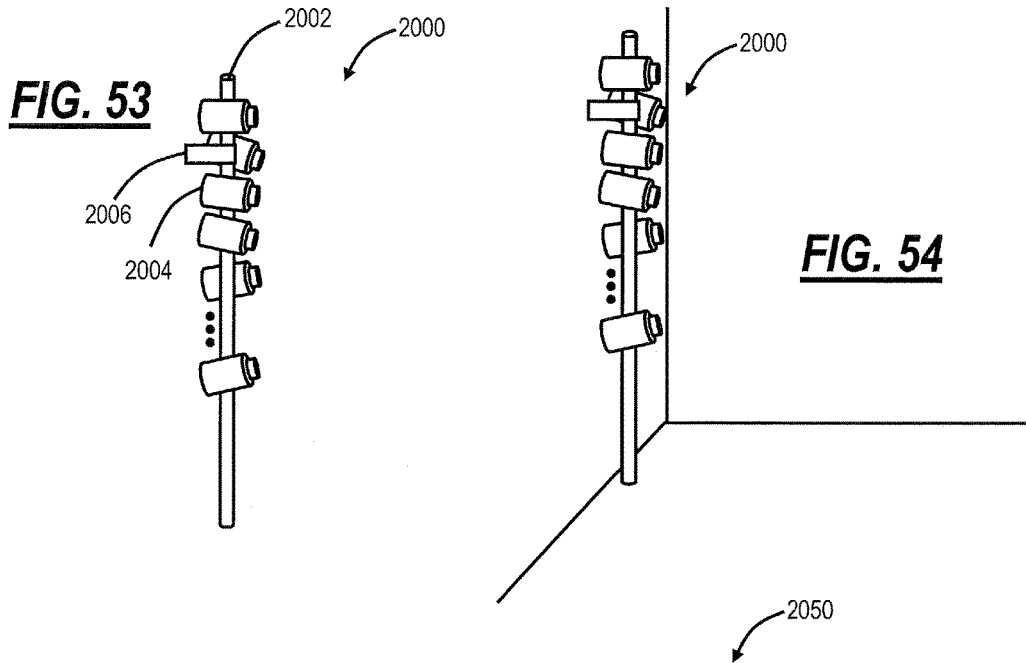


FIG. 55

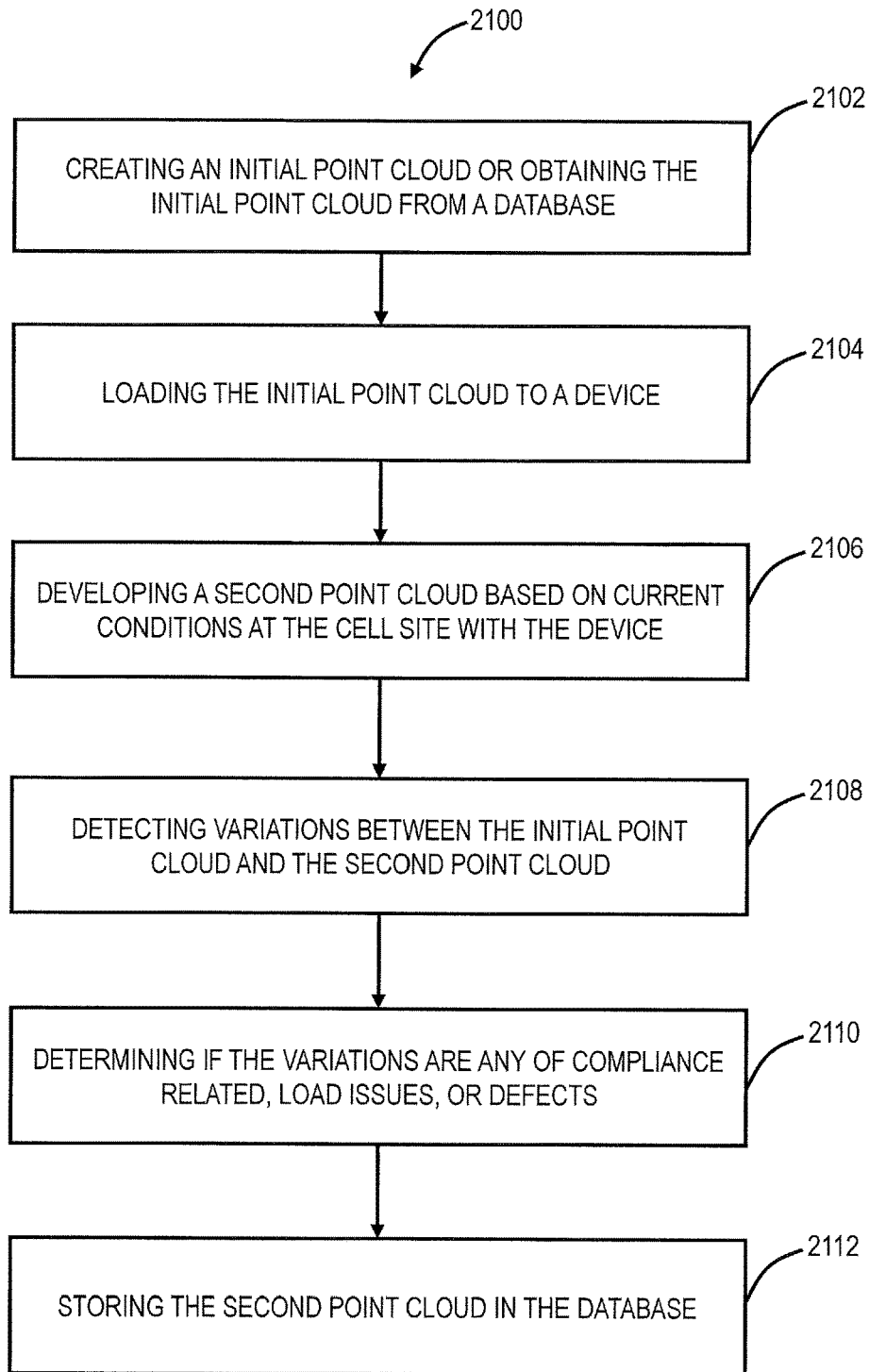


FIG. 56

**CELL SITE EQUIPMENT VERIFICATION
USING 3D MODELING COMPARISONS**

CROSS-REFERENCE TO RELATED
APPLICATION(S)

The present patent/application is continuation-in-part of and the content of each are incorporated by reference herein:

Filing Date	Ser. No.	Title
Oct. 31, 2016	15/338,700	SYSTEMS AND METHODS FOR OBTAINING ACCURATE 3D MODELING DATA USING UAVS FOR CELL SITES
Jun. 7, 2016	15/175,314	WIRELESS COVERAGE TESTING SYSTEMS AND METHODS WITH UNMANNED AERIAL VEHICLES
May 31, 2016	15/168,503	VIRTUALIZED SITE SURVEY SYSTEMS AND METHODS FOR CELL SITES
May 20, 2016	15/160,890	3D MODELING OF CELL SITES AND CELL TOWERS WITH UNMANNED AERIAL VEHICLES
Jun. 11, 2015	14/736,925	TETHERED UNMANNED AERIAL VEHICLE-BASED SYSTEMS AND METHODS ASSOCIATED WITH CELL SITES AND CELL TOWERS
Apr. 14, 2015	14/685,720	UNMANNED AERIAL VEHICLE-BASED SYSTEMS AND METHODS ASSOCIATED WITH CELL SITES AND CELL TOWERS

FIELD OF THE DISCLOSURE

The present disclosure relates generally to cell site maintenance systems and methods. More particularly, the present disclosure relates to systems and methods for verifying cell sites using accurate three-dimensional (3D) modeling data.

BACKGROUND OF THE DISCLOSURE

Due to the geographic coverage nature of wireless service, there are hundreds of thousands of cell towers in the United States. For example, in 2014, it was estimated that there were more than 310,000 cell towers in the United States. Cell towers can have heights up to 1,500 feet or more. There are various requirements for cell site workers (also referred to as tower climbers or transmission tower workers) to climb cell towers to perform maintenance, audit, and repair work for cellular phone and other wireless communications companies. This is both a dangerous and costly endeavor. For example, between 2003 and 2011, 50 tower climbers died working on cell sites (see, e.g., www.pbs.org/wgbh/pages/frontline/social-issues/cell-tower-deaths/in-race-for-better-cell-service-men-who-climb-towers-pay-with-their-lives/). Also, OSHA estimates that working on cell sites is 10 times more dangerous than construction work, generally (see, e.g., www.propublica.org/article/cell-tower-work-fatalities-methodology). Furthermore, the tower climbs also can lead to service disruptions caused by accidents. Thus, there is a strong desire, from both a cost and safety perspective, to reduce the number of tower climbs.

Concurrently, the use of unmanned aerial vehicles (UAV), referred to as drones, is evolving. There are limitations associated with UAVs, including emerging FAA rules and guidelines associated with their commercial use. It would be advantageous to leverage the use of UAVs to reduce tower climbs of cell towers. US 20140298181 to Rezvan describes methods and systems for performing a cell site audit remotely. However, Rezvan does not contemplate performing any activity locally at the cell site, nor various aspects of UAV use. US20120250010 to Hannay describes aerial inspections of transmission lines using drones. However, Hannay does not contemplate performing any activity

locally at the cell site, nor various aspects of constraining the UAV use. Specifically, Hannay contemplates a flight path in three dimensions along a transmission line.

Of course it would be advantageous to further utilize UAVs to actually perform operations on a cell tower. However, adding one or more robotic arms, carrying extra equipment, etc. presents a significantly complex problem in terms of UAV stabilization while in flight, i.e., counterbal-

ancing the UAV to account for the weight and movement of the robotic arms. Research and development continues in this area, but current solutions are complex and costly, eliminating the drivers for using UAVs for performing cell tower work.

3D modeling is important for cell site operators, cell tower owners, engineers, etc. There exist current techniques to make 3D models of physical sites such as cell sites. One approach is to take hundreds or thousands of pictures and to use software techniques to combine these pictures to form a 3D model. Generally, conventional approaches for obtaining the pictures include fixed cameras at the ground with zoom capabilities or pictures via tower climbers. It would be advantageous to utilize a UAV to obtain the pictures, providing 360 degree photos from an aerial perspective. Use of aerial pictures is suggested US 20100231687 to Armory. However, this approach generally assumes pictures taken from a fixed perspective relative to the cell site, such as via a fixed, mounted camera and a mounted camera in an aircraft. It has been determined that such an approach is moderately inaccurate during 3D modeling and combination with software due to slight variations in location tracking capabilities of systems such as Global Positioning Satellite (GPS). It would be advantageous to adapt a UAV to take pictures and provide systems and methods for accurate 3D modeling based thereon to again leverage the advantages of UAVs over tower climbers, i.e., safety, climbing speed and overall speed, cost, etc.

In the process of planning, installing, maintaining, and operating cell sites and cell towers, site surveys are performed for testing, auditing, planning, diagnosing, inventorying, etc. Conventional site surveys involve physical site access including access to the top of the cell tower, the interior of any buildings, cabinets, shelters, huts, hardened structures, etc. at the cell site, and the like. With over 200,000 cell sites in the U.S., geographically distributed everywhere, site surveys can be expensive, time-consuming, and complex. The various parent applications associated herewith describe techniques to utilize UAVs to optimize and provide safer site surveys. It would also be advantageous to further optimize site surveys by minimizing travel through virtualization of the entire process.

Wireless coverage testing is important for service providers and consumers—it is used for marketing purposes (who has the better network) and for engineering purposes (where do we need to augment or improve our coverage). Conventional approaches to wireless coverage testing utilize so-called drive tests where wireless coverage is tested by physically driving around a region with a test device and making measurements along the way. The conventional approaches are limited to ground coverage, not aerial coverage, as conventional drive tests are just that—driven by a vehicle on the ground. The Federal Aviation Administration (FAA) is investigating use of the wireless network in some manner for air traffic control of UAVs. Thus, there is a need to extend conventional drive tests to support wireless coverage testing above the ground.

As networks evolve, there is a continuous need to install equipment on cell towers, such as antennas, radios, and the like. Such equipment can weigh greater than 100 lbs, requiring construction equipment to raise it to the top of the cell tower or the like. Of course, the convention approach also requires tower climbs, is expensive, and inefficient. It would be advantageous to improve these approaches using UAVs, to reduce requirements for tower climbs, eliminate the need for construction equipment, lower cost, and improve installation time.

Again, with over 200,000 cell sites in the U.S., each time there is maintenance or installation activity at each cell site, operators and owners typically require a close-out audit which is done to document and verify the work performed. For example, the maintenance or installation activity can be performed by a third-party installation firm (separate from an operator or owner) and an objective of the close-out audit is to provide the operator or owner verification of the work as well as that the third-party installation firm did the work in a manner consistent with the operator or owner's expectations. Conventionally, close-out audits are performed by another firm, i.e., a third-party inspection firm, separate from the third-party installation firm, the owner, and the operator. Disadvantageously, this conventional approach with a separate third-party inspection firm is inefficient, expensive, etc.

Also, with over 200,000 cell sites, it is difficult to monitor activity, namely configurations, physical structure, surroundings, etc., and associated changes. The typical arrangement includes a cell site owner, which is typically a real estate company, leasing space to cell site operators, i.e., wireless service providers. It is incumbent that the cell site owners maintain accurate records of the cell sites, including the configuration (i.e., are the operators deploying more equipment than agreements state?), physical structure (i.e., are there mechanic issues with the cell site?), surroundings (i.e., are there safety issues?), and the like. Conventional approaches require physical site surveys to obtain such information which with over 200,000 cells sites is expensive, time consuming, slow, etc.

Of course, there are still requirements to perform tower climbs for some installation and maintenance activity at cell towers. In addition to the aforementioned safety issues, another large drawback of conventional tower climbs is the time and physical effort involved. To climb to the top, personnel must climb in increments and continually hook in to safety harnesses. Once at the top, the personnel must rest to recover from climbing several hundred feet. Conventional tower climbs can take well over an hour, lead the personnel to exhaustion, etc.

BRIEF SUMMARY OF THE DISCLOSURE

In an exemplary embodiment, systems and method for verifying a cell site utilizing an Unmanned Aerial Vehicle

(UAV) include providing an initial point cloud related to the cell site to the UAV; developing a second point cloud based on current conditions at the cell site, wherein the second point cloud is based on data acquisition using the UAV at the cell site; detecting variations between the initial point cloud and the second point cloud; and, responsive to detecting the variations, determining whether the variations are any of compliance related, load issues, and defects associated with any equipment or structures at the cell site.

BRIEF DESCRIPTION OF THE DRAWINGS

The present disclosure is illustrated and described herein with reference to the various drawings, in which like reference numbers are used to denote like system components/method steps, as appropriate, and in which:

FIG. 1 is a diagram of a side view of an exemplary cell site;

FIG. 2 is a diagram of a cell site audit performed with an UAV;

FIG. 3 is a screen diagram of a view of a graphical user interface (GUI) on a mobile device while piloting the UAV;

FIG. 4 is a perspective view of an exemplary UAV;

FIG. 5 is a block diagram of a mobile device;

FIG. 6 is a flow chart of a cell site audit method utilizing the UAV and the mobile device;

FIG. 7 is a network diagram of various cell sites deployed in a geographic region;

FIG. 8 is a diagram of a tethered configuration with a UAV at a cell site;

FIG. 9 is a diagram of another tethered configuration with a UAV at a cell site;

FIG. 10 is a flowchart of a method with a tethered UAV associated with a cell site;

FIG. 11 is a diagram of a UAV with robotic arms at a cell site;

FIG. 12 is a block diagram of the UAV with robotic arms and a payload at a cell site;

FIG. 13 is a flowchart of a method with a UAV with robotic arms at a cell site;

FIG. 14 is a diagram of the cell site and an associated launch configuration and flight for the UAV to obtain photos for a 3D model of the cell site;

FIG. 15 is a satellite view of an exemplary flight of the UAV at the cell site;

FIG. 16 is a side view of an exemplary flight of the UAV at the cell site;

FIG. 17 is a logical diagram of a portion of a cell tower along with associated photos taken by the UAV at different points relative thereto;

FIG. 18 is a screen shot of a GUI associated with post processing photos from the UAV;

FIG. 19 is a screen shot of a 3D model constructed from a plurality of 2D photos taken from the UAV as described herein;

FIGS. 20-25 are various screen shots illustrate GUIs associated with a 3D model of a cell site based on photos taken from the UAV as described herein;

FIG. 26 is a photo of the UAV in flight at the top of a cell tower;

FIG. 27 is a flowchart of a process for modeling a cell site with an Unmanned Aerial Vehicle (UAV);

FIG. 28 is a diagram of an exemplary interior of a building, such as the shelter or cabinet, at the cell site;

FIG. 29 is a flowchart of a virtual site survey process for the cell site;

FIG. 30 is a block diagram of functional components associated with the UAV to support wireless coverage testing;

FIG. 31 is a map and associated coverage areas for describing conventional drive testing;

FIG. 32 is a 3D view of a cell tower with an associated coverage area in three dimensions—x, y, and z for illustrating UAV-based wireless coverage testing;

FIG. 33 is a flowchart of a UAV-based wireless coverage testing process;

FIG. 34 is a diagram of a partial view of the exemplary cell site for describing installation of equipment with the UAV;

FIG. 35 is a diagram of a view of the horizontal support structures on the cell tower and the antenna for describing installation of equipment with the UAV;

FIG. 36 is a flowchart of an Unmanned Aerial Vehicle (UAV)-based installation method for equipment on cell towers;

FIGS. 37A-37C are diagrams of different types of cell towers, namely a self-support tower (FIG. 37A), a monopole tower (FIG. 37B), and a guyed tower (FIG. 37C);

FIG. 38 is a block diagram illustrates a robotic device configured for use with the cell towers for installation and/or maintenance of cell site components on the cell towers;

FIG. 39 is a flowchart of a method for installation and maintenance of cell site components with the robotic device;

FIG. 40 is a flowchart illustrates a close-out audit method performed at a cell site subsequent to maintenance or installation work;

FIG. 41 is a flowchart of a 3D modeling method to detect configuration and site changes;

FIG. 42 is a diagram of a drone adapted to transport a person up a cell tower;

FIG. 43 is a diagram of another drone adapted to transport a person up the cell tower;

FIG. 44 is a diagram of a system adapted to transport a person up the cell tower;

FIG. 45 is a diagram of a cell tower with platforms for receiving a person from a drone;

FIG. 46 is a flowchart of a method for transporting maintenance personnel to a cell tower;

FIGS. 47A, 47B, and 47C are diagrams of various counterbalance techniques for the UAV including an extendible arm (FIG. 47A), opposing robotic arms (FIG. 47B), and moveable weights (FIG. 47C);

FIG. 48 is a flow diagram of a 3D model creation process;

FIG. 49 is a flowchart of a method using an Unmanned Aerial Vehicle (UAV) to obtain data capture at a cell site for developing a three dimensional (3D) thereof;

FIG. 50 is a flowchart of a 3D modeling method for capturing data at the cell site, the cell tower, etc. using the UAV;

FIGS. 51A and 51B are block diagrams of a UAV with multiple cameras (FIG. 51A) and a camera array (FIG. 51B);

FIG. 52 is a flowchart of a method using multiple cameras to obtain accurate three-dimensional (3D) modeling data;

FIGS. 53 and 54 are diagrams of a multiple camera apparatus and use of the multiple camera apparatus in a shelter or cabinet or the interior of a building; and

FIG. 55 is a flowchart of a data capture method in the interior of a building using the multiple camera apparatus; and

FIG. 56 is a flowchart of a method for verifying equipment and structures at the cell site using 3D modeling.

DETAILED DESCRIPTION OF THE DISCLOSURE

Again, in an exemplary embodiment, the present disclosure relates to systems and methods for verifying cell sites using accurate three-dimensional (3D) modeling data. In an exemplary embodiment, systems and method for verifying a cell site utilizing an Unmanned Aerial Vehicle (UAV) include providing an initial point cloud related to the cell site to the UAV; developing a second point cloud based on current conditions at the cell site, wherein the second point cloud is based on data acquisition using the UAV at the cell site; detecting variations between the initial point cloud and the second point cloud; and, responsive to detecting the variations, determining whether the variations are any of compliance related, load issues, and defects associated with any equipment or structures at the cell site.

Further, in an exemplary embodiment, present disclosure relates to systems and methods for obtaining accurate three-dimensional (3D) modeling data using a multiple camera apparatus. Specifically, the multiple camera apparatus contemplates use in a shelter or the like to simultaneously obtain multiple photos for purposes of developing a three-dimensional (3D) model of the shelter for use in a cell site audit or the like. The multiple camera apparatus can be portable or mounted within the shelter. The multiple camera apparatus includes a support beam with a plurality of cameras associated therewith. The plurality of cameras each face a different direction, angle, zoom, etc. and are coordinated to simultaneously obtain photos. Once obtained, the photos can be used to create a 3D model. Advantageously, the multiple camera apparatus streamlines data acquisition time as well as ensures the proper angles and photos are obtained. The multiple camera apparatus also is simply to use allowing untrained technicians the ability to easily perform data acquisition.

Further, in an exemplary embodiment, the present disclosure relates to systems and methods for obtaining accurate three-dimensional (3D) modeling data using multiple cameras such as with Unmanned Aerial Vehicles (UAVs) (also referred to as “drones”) or the like at cell sites, cell towers, etc. The systems and methods utilize two or more cameras simultaneously to capture the modeling data and associated synchronization techniques to ensure the modeling data is accurately and timely captured. The multiple cameras can be part of a camera array. The camera array can be a single hardware entity or on different UAVs. Various, the multiple cameras are communicatively coupled to one another and configured to take photos together, such as the same time, but different vantage points, angles, perspective, etc. Taking the photos together enables efficient data capture to create 3D models, such as at cell sites. Using the systems and methods herein, the process of data capture can be at least twice as fast which is important for field operations where multiple cell sites need to be characterized.

Further, in an exemplary embodiment, the present disclosure relates to systems and methods for obtaining three-dimensional (3D) modeling data using Unmanned Aerial Vehicles (UAVs) (also referred to as “drones”) or the like at cell sites, cell towers, etc. Various, the systems and methods describe various techniques using UAVs or the like to obtain data, i.e., pictures and/or video, used to subsequently create a 3D model of a cell site. Various uses of the 3D model are also described including site surveys, site monitoring, engineering, etc.

Further, in an exemplary embodiment, the present disclosure relates to counterbalancing techniques when using

Unmanned Aerial Vehicles (UAVs) “drones” or the like to perform operations on cell towers. Specifically, UAVs can be used, as described herein, for various monitoring functions such as cell site audits and inspections. Also, UAVs can be adapted to perform physical functions replacing a technician and avoiding a tower climb. In various exemplary embodiments described herein, UAVs can be used at cell towers to bring equipment up (e.g., antennas), use robotic arms for manipulating and carrying objects, to connect to the cell tower for stabilization, to carry personnel up the cell tower, etc. In these various applications, the counterbalancing techniques ensure proper flight of the UAV avoiding sudden weight distribution changes in the UAV which negatively affect the flight.

Further, in an exemplary embodiment, the present disclosure relates to three-dimensional (3D) modeling of cell sites to detect configuration and site changes. Again, the challenge for cell site owners is to manage thousands of cell sites which are geographically distributed. The 3D modeling systems and methods utilize various techniques to obtain data, to create 3D models, and to detect changes in configurations and surroundings. The 3D models can be created at two or more different points in time, and with the different 3D models, a comparison can be made to detect the changes. Advantageously, the 3D modeling systems and methods allow cell site operators to efficiently manage the cell sites without repeated physical site surveys.

Further, in various exemplary embodiments, the present disclosure relates to close-out audit systems and methods for cell site installation and maintenance. Specifically, the systems and methods eliminate the separate third-party inspection firm for the close-out audit. The systems and methods include the installers (i.e., from the third-party installation firm, the owner, the operator, etc.) performing video capture subsequent to the installation and maintenance and using various techniques to obtain data from the video capture for the close-out audit. The close-out audit can be performed off-site with the data from the video capture thereby eliminating unnecessary tower climbs, site visits, and the like.

Further, in various exemplary embodiments, the present disclosure relates to wireless coverage testing systems and methods with unmanned aerial vehicles (UAVs). Specifically, a UAV is equipment with equipment for performing a wireless coverage test, e.g., wireless scanners, location identification equipment, antennas, and processing and data storage equipment. The UAV is flown about a cell tower around a region, taking measurements along the way. Subsequently, processing on the measurements enables the assessment of wireless coverage not just near the ground, but in the aerial region about the cell tower in the region. It is expected such measurements and assessments can be used to ensure proper wireless coverage in the air, such as up to 100’s of feet, enabling the cell tower to act as an air traffic control point for UAVs flying in the region as well as a central hub for managing and controlling UAVs. Additionally, the wireless coverage testing systems and methods provide a quicker and more efficient improvement over conventional drive tests solely on the ground.

Further, in various exemplary embodiments, the present disclosure relates to virtualized site survey systems and methods using three-dimensional (3D) modeling of cell sites and cell towers with and without unmanned aerial vehicles. The virtualized site survey systems and methods utilizing photo data capture along with location identifiers, points of interest, etc. to create three-dimensional (3D) modeling of all aspects of the cell sites, including interiors of buildings, cabinets, shelters, huts, hardened structures, etc. As

described herein, a site survey can also include a site inspection, cell site audit, or anything performed based on the 3D model of the cell site including building interiors. With the data capture, 3D modeling can render a completely virtual representation of the cell sites. The data capture can be performed by on-site personnel, automatically with fixed, networked cameras, or a combination thereof. With the data capture and the associated 3D model, engineers and planners can perform site surveys, without visiting the sites leading to significant efficiency in cost and time. From the 3D model, any aspect of the site survey can be performed remotely including determinations of equipment location, accurate spatial rendering, planning through drag and drop placement of equipment, access to actual photos through a Graphical User Interface, indoor texture mapping, and equipment configuration visualization mapping the equipment in a 3D rack.

Further, in various exemplary embodiments, the present disclosure relates to three-dimensional (3D) modeling of cell sites and cell towers with unmanned aerial vehicles. The present disclosure includes UAV-based systems and methods for 3D modeling and representing of cell sites and cell towers. The systems and methods include obtaining various pictures via a UAV at the cell site, flying around the cell site to obtain various different angles of various locations, tracking the various pictures (i.e., enough pictures to produce an acceptable 3D model, usually hundreds, but could be more) with location identifiers, and processing the various pictures to develop a 3D model of the cell site and the cell tower. Additionally, the systems and methods focus on precision and accuracy ensuring the location identifiers are as accurate as possible for the processing by using multiple different location tracking techniques as well as ensuring the UAV is launched from a same location and/or orientation for each flight. The same location and/or orientation, as described herein, was shown to provide more accurate location identifiers versus arbitrary location launches and orientations for different flights. Additionally, once the 3D model is constructed, the systems and methods include an application which enables cell site owners and cell site operators to “click” on any location and obtain associated photos, something extremely useful in the ongoing maintenance and operation thereof. Also, once constructed, the 3D model is capable of various measurements including height, angles, thickness, elevation, even Radio Frequency (RF), and the like.

Still further, in additional exemplary embodiments, UAV-based systems and methods are described associated with cell sites, such as for providing cell tower audits and the like, including a tethered configuration. Various aspects of UAVs are described herein to reduce tower climbs in conjunction with cell tower audits. Additional aspects are described utilizing UAVs for other functions, such as flying from cell tower to cell tower to provide audit services and the like. Advantageously, using UAVs for cell tower audits exponentially improves the safety of cell tower audits and has been shown by Applicants to reduce costs by over 40%, as well as drastically improving audit time. With the various aspects described herein, a UAV-based audit can provide superior information and quality of such information, including a 360 degree tower view. In one aspect, the systems and methods include a constrained flight zone for the UAV such as a three-dimensional rectangle (an “ice cube” shape) about the cell tower. This constrained flight zone allows the systems and methods to operate the UAV without extensive regulations such as including extra personnel for “spotting” and requiring private pilot’s licenses.

§ 1.0 Exemplary Cell Site

Referring to FIG. 1, in an exemplary embodiment, a diagram illustrates a side view of an exemplary cell site 10. The cell site 10 includes a cell tower 12. The cell tower 12 can be any type of elevated structure, such as 100-200 feet/30-60 meters tall. Generally, the cell tower 12 is an elevated structure for holding cell site components 14. The cell tower 12 may also include a lightning rod 16 and a warning light 18. Of course, there may be various additional components associated with the cell tower 12 and the cell site 10 which are omitted for illustration purposes. In this exemplary embodiment, there are four sets 20, 22, 24, 26 of cell site components 14, such as for four different wireless service providers. In this example, the sets 20, 22, 24 include various antennas 30 for cellular service. The sets 20, 22, 24 are deployed in sectors, e.g. there can be three sectors for the cell site components alpha, beta, and gamma. The antennas 30 are used to both transmit a radio signal to a mobile device and receive the signal from the mobile device. The antennas 30 are usually deployed as a single, groups of two, three or even four per sector. The higher the frequency of spectrum supported by the antenna 30, the shorter the antenna 30. For example, the antennas 30 may operate around 850 MHz, 1.9 GHz, and the like. The set 26 includes a microwave dish 32 which can be used to provide other types of wireless connectivity, besides cellular service. There may be other embodiments where the cell tower 12 is omitted and replaced with other types of elevated structures such as roofs, water tanks, etc.

§ 2.0 Cell Site Audits Via UAV

Referring to FIG. 2, in an exemplary embodiment, a diagram illustrates a cell site audit 40 performed with an unmanned aerial vehicle (UAV) 50. As described herein, the cell site audit 40 is used by service providers, third party engineering companies, tower operators, etc. to check and ensure proper installation, maintenance, and operation of the cell site components 14 and shelter or cabinet 52 equipment as well as the various interconnections between them. From a physical accessibility perspective, the cell tower 12 includes a climbing mechanism 54 for tower climbers to access the cell site components 14. FIG. 2 includes a perspective view of the cell site 10 with the sets 20, 26 of the cell site components 14. The cell site components 14 for the set 20 include three sectors—alpha sector 54, beta sector 56, and gamma sector 58.

In an exemplary embodiment, the UAV 50 is utilized to perform the cell site audit 40 in lieu of a tower climber access the cell site components 14 via the climbing mechanism 54. In the cell site audit 40, an engineer/technician is local to the cell site 10 to perform various tasks. The systems and methods described herein eliminate a need for the engineer/technician to climb the cell tower 12. Of note, it is still important for the engineer/technician to be local to the cell site 10 as various aspects of the cell site audit 40 cannot be done remotely as described herein. Furthermore, the systems and methods described herein provide an ability for a single engineer/technician to perform the cell site audit 40 without another person handling the UAV 50 or a person with a pilot's license operating the UAV 50 as described herein.

§ 2.1 Cell Site Audit

In general, the cell site audit 40 is performed to gather information and identify a state of the cell site 10. This is used to check the installation, maintenance, and/or operation of the cell site 10. Various aspects of the cell site audit 40 can include, without limitation:

-
- Verify the cell site 10 is built according to a current revision
 - Verify Equipment Labeling
 - Verify Coax Cable ("Coax") Bend Radius
 - Verify Coax Color Coding/Tagging
 - Check for Coax External Kinks & Dents
 - Verify Coax Ground Kits
 - Verify Coax Hanger/Support
 - Verify Coax Jumpers
 - Verify Coax Size
 - Check for Connector Stress & Distortion
 - Check for Connector Weatherproofing
 - Verify Correct Duplexers/Diplexers Installed
 - Verify Duplexer/Diplexer Mounting
 - Verify Duplexers/Diplexers Installed Correctly
 - Verify Fiber Paper
 - Verify Lacing & Tie Wraps
 - Check for Loose or Cross-Threaded Coax Connectors
 - Verify Return ("Ret") Cables
 - Verify Ret Connectors
 - Verify Ret Grounding
 - Verify Ret Installation
 - Verify Ret Lightning Protection Unit (LPI)
 - Check for Shelter/Cabinet Penetrations
 - Verify Surge Arrestor Installation/Grounding
 - Verify Site Cleanliness
 - Verify LTE GPS Antenna Installation
-

Of note, the cell site audit 40 includes gathering information at and inside the shelter or cabinet 52, on the cell tower 12, and at the cell site components 14. Note, it is not possible to perform all of the above items solely with the UAV 50 or remotely.

§ 3.0 Piloting the UAV at the Cell Site

It is important to note that the Federal Aviation Administration (FAA) is in the process of regulating commercial UAV (drone) operation. It is expected that these regulations would not be complete until 2016 or 2017. In terms of these regulations, commercial operation of the UAV 50, which would include the cell site audit 40, requires at least two people, one acting as a spotter and one with a pilot's license. These regulations, in the context of the cell site audit 40, would make use of the UAV 50 impractical. To that end, the systems and methods described herein propose operation of the UAV 50 under FAA exemptions which allow the cell site audit 40 to occur without requiring two people and without requiring a pilot's license. Here, the UAV 50 is constrained to fly up and down at the cell site 10 and within a three-dimensional (3D) rectangle at the cell site components. These limitations on the flight path of the UAV 50 make the use of the UAV 50 feasible at the cell site 10.

Referring to FIG. 3, in an exemplary embodiment, a screen diagram illustrates a view of a graphical user interface (GUI) 60 on a mobile device 100 while piloting the UAV 50. The GUI 60 provides a real-time view to the engineer/technician piloting the UAV 50. That is, a screen 62 provides a view from a camera on the UAV 50. As shown in FIG. 3, the cell site 10 is shown with the cell site components 14 in the view of the screen 62. Also, the GUI 60 have various controls 64, 66. The controls 64 are used to pilot the UAV 50 and the controls 66 are used to perform functions in the cell site audit 40 and the like.

§ 3.1 FAA Regulations

The FAA is overwhelmed with applications from companies interested in flying drones, but the FAA is intent on keeping the skies safe. Currently, approved exemptions for flying drones include tight rules. Once approved, there is some level of certification for drone operators along with specific rules such as, speed limit of 100 mph, height limitations such as 400 ft, no-fly zones, day only operation, documentation, and restrictions on aerial filming. Accord-

ingly, flight at or around cell towers is constrained and the systems and methods described herein fully comply with the relevant restrictions associated with drone flights from the FAA.

§ 4.0 Exemplary Hardware

Referring to FIG. 4, in an exemplary embodiment, a perspective view illustrates an exemplary UAV 50 for use with the systems and methods described herein. Again, the UAV 50 may be referred to as a drone or the like. The UAV 50 may be a commercially available UAV platform that has been modified to carry specific electronic components as described herein to implement the various systems and methods. The UAV 50 includes rotors 80 attached to a body 82. A lower frame 84 is located on a bottom portion of the body 82, for landing the UAV 50 to rest on a flat surface and absorb impact during landing. The UAV 50 also includes a camera 86 which is used to take still photographs, video, and the like. Specifically, the camera 86 is used to provide the real-time display on the screen 62. The UAV 50 includes various electronic components inside the body 82 and/or the camera 86 such as, without limitation, a processor, a data store, memory, a wireless interface, and the like. Also, the UAV 50 can include additional hardware, such as robotic arms or the like that allow the UAV 50 to attach/detach components for the cell site components 14. Specifically, it is expected that the UAV 50 will get bigger and more advanced, capable of carrying significant loads, and not just a wireless camera. The present disclosure contemplates using the UAV 50 for various aspects at the cell site 10, including participating in construction or deconstruction of the cell tower 12, the cell site components 14, etc.

These various components are now described with reference to a mobile device 100. Those of ordinary skill in the art will recognize the UAV 50 can include similar components to the mobile device 100. Of note, the UAV 50 and the mobile device 100 can be used cooperatively to perform various aspects of the cell site audit 40 described herein. In other embodiments, the UAV 50 can be operated with a controller instead of the mobile device 100. The mobile device 100 may solely be used for real-time video from the camera 86 such as via a wireless connection (e.g., IEEE 802.11 or variants thereof). Some portions of the cell site audit 40 can be performed with the UAV 50, some with the mobile device 100, and others solely by the operator through visual inspection. In some embodiments, all of the aspects can be performed in the UAV 50. In other embodiments, the UAV 50 solely relays data to the mobile device 100 which performs all of the aspects. Other embodiments are also contemplated.

Referring to FIG. 5, in an exemplary embodiment, a block diagram illustrates a mobile device 100, which may be used for the cell site audit 40 or the like. The mobile device 100 can be a digital device that, in terms of hardware architecture, generally includes a processor 102, input/output (I/O) interfaces 104, wireless interfaces 106, a data store 108, and memory 110. It should be appreciated by those of ordinary skill in the art that FIG. 5 depicts the mobile device 100 in an oversimplified manner, and a practical embodiment may include additional components and suitably configured processing logic to support known or conventional operating features that are not described in detail herein. The components (102, 104, 106, 108, and 110) are communicatively coupled via a local interface 112. The local interface 112 can be, for example but not limited to, one or more buses or other wired or wireless connections, as is known in the art. The local interface 112 can have additional elements, which are omitted for simplicity, such as controllers, buffers (caches),

drivers, repeaters, and receivers, among many others, to enable communications. Further, the local interface 112 may include address, control, and/or data connections to enable appropriate communications among the aforementioned components.

The processor 102 is a hardware device for executing software instructions. The processor 102 can be any custom made or commercially available processor, a central processing unit (CPU), an auxiliary processor among several processors associated with the mobile device 100, a semiconductor-based microprocessor (in the form of a microchip or chip set), or generally any device for executing software instructions. When the mobile device 100 is in operation, the processor 102 is configured to execute software stored within the memory 110, to communicate data to and from the memory 110, and to generally control operations of the mobile device 100 pursuant to the software instructions. In an exemplary embodiment, the processor 102 may include a mobile optimized processor such as optimized for power consumption and mobile applications. The I/O interfaces 104 can be used to receive user input from and/or for providing system output. User input can be provided via, for example, a keypad, a touch screen, a scroll ball, a scroll bar, buttons, bar code scanner, and the like. System output can be provided via a display device such as a liquid crystal display (LCD), touch screen, and the like. The I/O interfaces 104 can also include, for example, a serial port, a parallel port, a small computer system interface (SCSI), an infrared (IR) interface, a radio frequency (RF) interface, a universal serial bus (USB) interface, and the like. The I/O interfaces 104 can include a graphical user interface (GUI) that enables a user to interact with the mobile device 100. Additionally, the I/O interfaces 104 may further include an imaging device, i.e. camera, video camera, etc.

The wireless interfaces 106 enable wireless communication to an external access device or network. Any number of suitable wireless data communication protocols, techniques, or methodologies can be supported by the wireless interfaces 106, including, without limitation: RF; IrDA (infrared); Bluetooth; ZigBee (and other variants of the IEEE 802.15 protocol); IEEE 802.11 (any variation); IEEE 802.16 (WiMAX or any other variation); Direct Sequence Spread Spectrum; Frequency Hopping Spread Spectrum; Long Term Evolution (LTE); cellular/wireless/cordless telecommunication protocols (e.g. 3G/4G, etc.); wireless home network communication protocols; paging network protocols; magnetic induction; satellite data communication protocols; wireless hospital or health care facility network protocols such as those operating in the WMTS bands; GPRS; proprietary wireless data communication protocols such as variants of Wireless USB; and any other protocols for wireless communication. The wireless interfaces 106 can be used to communicate with the UAV 50 for command and control as well as to relay data therebetween. The data store 108 may be used to store data. The data store 108 may include any of volatile memory elements (e.g., random access memory (RAM, such as DRAM, SRAM, SDRAM, and the like)), nonvolatile memory elements (e.g., ROM, hard drive, tape, CDROM, and the like), and combinations thereof. Moreover, the data store 108 may incorporate electronic, magnetic, optical, and/or other types of storage media.

The memory 110 may include any of volatile memory elements (e.g., random access memory (RAM, such as DRAM, SRAM, SDRAM, etc.)), nonvolatile memory elements (e.g., ROM, hard drive, etc.), and combinations thereof. Moreover, the memory 110 may incorporate elec-

tronic, magnetic, optical, and/or other types of storage media. Note that the memory **110** may have a distributed architecture, where various components are situated remotely from one another, but can be accessed by the processor **102**. The software in memory **110** can include one or more software programs, each of which includes an ordered listing of executable instructions for implementing logical functions. In the example of FIG. **5**, the software in the memory **110** includes a suitable operating system (O/S) **114** and programs **116**. The operating system **114** essentially controls the execution of other computer programs, and provides scheduling, input-output control, file and data management, memory management, and communication control and related services. The programs **116** may include various applications, add-ons, etc. configured to provide end user functionality with the mobile device **100**, including performing various aspects of the systems and methods described herein.

It will be appreciated that some exemplary embodiments described herein may include one or more generic or specialized processors (“one or more processors”) such as microprocessors, digital signal processors, customized processors, and field programmable gate arrays (FPGAs) and unique stored program instructions (including both software and firmware) that control the one or more processors to implement, in conjunction with certain non-processor circuits, some, most, or all of the functions of the methods and/or systems described herein. Alternatively, some or all functions may be implemented by a state machine that has no stored program instructions, or in one or more application specific integrated circuits (ASICs), in which each function or some combinations of certain of the functions are implemented as custom logic. Of course, a combination of the aforementioned approaches may be used. Moreover, some exemplary embodiments may be implemented as a non-transitory computer-readable storage medium having computer readable code stored thereon for programming a computer, server, appliance, device, etc. each of which may include a processor to perform methods as described and claimed herein. Examples of such computer-readable storage mediums include, but are not limited to, a hard disk, an optical storage device, a magnetic storage device, a ROM (Read Only Memory), a PROM (Programmable Read Only Memory), an EPROM (Erasable Programmable Read Only Memory), an EEPROM (Electrically Erasable Programmable Read Only Memory), Flash memory, and the like. When stored in the non-transitory computer readable medium, software can include instructions executable by a processor that, in response to such execution, cause a processor or any other circuitry to perform a set of operations, steps, methods, processes, algorithms, etc.

§ 4.1 RF Sensors in the UAV

In an exemplary embodiment, the UAV **50** can also include one or more RF sensors disposed therein. The RF sensors can be any device capable of making wireless measurements related to signals associated with the cell site components **14**, i.e., the antennas. In an exemplary embodiment, the UAV **50** can be further configured to fly around a cell zone associated with the cell site **10** to identify wireless coverage through various measurements associated with the RF sensors.

§ 5.0 Cell Site Audit with UAV and/or Mobile Device

Referring to FIG. **6**, in an exemplary embodiment, a flow chart illustrates a cell site audit method **200** utilizing the UAV **50** and the mobile device **100**. Again, in various exemplary embodiments, the cell site audit **40** can be performed with the UAV **50** and the mobile device **100**. In

other exemplary embodiments, the cell site audit **40** can be performed with the UAV **50** and an associated controller. In other embodiments, the mobile device **100** is solely used to relay real-time video from the camera **86**. While the steps of the cell site audit method **200** are listed sequentially, those of ordinary skill in the art will recognize some or all of the steps may be performed in a different order. The cell site audit method **200** includes an engineer/technician at a cell site with the UAV **50** and the mobile device **100** (step **202**). Again, one aspect of the systems and methods described herein is usage of the UAV **50**, in a commercial setting, but with constraints such that only one operator is required and such that the operator does not have to hold a pilot’s license. As described herein, the constraints can include flight of the UAV **50** at or near the cell site **10** only, a flight pattern up and down in a 3D rectangle at the cell tower **12**, a maximum height restriction (e.g., 500 feet or the like), and the like. For example, the cell site audit **40** is performed by one of i) a single operator flying the UAV **50** without a license or ii) two operators including one with a license and one to spot the UAV **50**.

The engineer/technician performs one or more aspects of the cell site audit **40** without the UAV **50** (step **204**). Note, there are many aspects of the cell site audit **40** as described herein. It is not possible for the UAV **50** to perform all of these items such that the engineer/technician could be remote from the cell site **10**. For example, access to the shelter or cabinet **52** for audit purposes requires the engineer/technician to be local. In this step, the engineer/technician can perform any audit functions as described herein that do not require climbing.

The engineer/technician can cause the UAV **50** to fly up the cell tower **12** or the like to view cell site components **14** (step **206**). Again, this flight can be based on the constraints, and the flight can be through a controller and/or the mobile device **100**. The UAV **50** and/or the mobile device **100** can collect data associated with the cell site components **14** (step **208**), and process the collected data to obtain information for the cell site audit **40** (step **210**). As described herein, the UAV **50** and the mobile device **100** can be configured to collect data via video and/or photographs. The engineer/technician can use this collected data to perform various aspects of the cell site audit **40** with the UAV **50** and the mobile device **100** and without a tower climb.

The foregoing descriptions detail specific aspects of the cell site audit **40** using the UAV **50** and the mobile device **100**. In these aspects, data can be collected—generally, the data is video or photographs of the cell site components **14**. The processing of the data can be automated through the UAV **50** and/or the mobile device **100** to compute certain items as described herein. Also, the processing of the data can be performed either at the cell site **10** or afterwards by the engineer/technician.

In an exemplary embodiment, the UAV **50** can be a commercial, “off-the-shelf” drone with a Wi-Fi enabled camera for the camera **86**. Here, the UAV **50** is flown with a controller pad which can include a joystick or the like. Alternatively, the UAV **50** can be flown with the mobile device **100**, such as with an app installed on the mobile device **100** configured to control the UAV **50**. The Wi-Fi enable camera is configured to communicate with the mobile device **100**—to both display real-time video and audio as well as to capture photos and/or video during the cell site audit **40** for immediate processing or for later processing to gather relevant information about the cell site components **14** for the cell site audit **40**.

In another exemplary embodiment, the UAV **50** can be a so-called “drone in a box” which is preprogrammed/configured to fly a certain route, such as based on the flight constraints described herein. The “drone in a box” can be physically transported to the cell site **10** or actually located there. The “drone in a box” can be remotely controlled as well.

§ 5.1 Antenna Down Tilt Angle

In an exemplary aspect of the cell site audit **40**, the UAV **50** and/or the mobile device **100** can be used to determine a down tilt angle of individual antennas **30** of the cell site components **14**. The down tilt angle can be determined for all of the antennas **30** in all of the sectors **54**, **56**, **58**. The down tilt angle is the mechanical (external) down tilt of the antennas **30** relative to a support bar **200**. In the cell site audit **40**, the down tilt angle is compared against an expected value, such as from a Radio Frequency (RF) data sheet, and the comparison may check to ensure the mechanical (external) down tilt is within $\pm 1.0^\circ$ of specification on the RF data sheet.

Using the UAV **50** and/or the mobile device **100**, the down tilt angle is determined from a photo taken from the camera **86**. In an exemplary embodiment, the UAV **50** and/or the mobile device **100** is configured to measure three points—two defined by the antenna **30** and one by the support bar **200** to determine the down tilt angle of the antenna **30**. For example, the down tilt angle can be determined visually from the side of the antenna **30**—measuring a triangle formed by a top of the antenna **30**, a bottom of the antenna **30**, and the support bar **200**.

§ 5.2 Antenna Plumb

In an exemplary aspect of the cell site audit **40** and similar to determining the down tilt angle, the UAV **50** and/or the mobile device **100** can be used to visually inspect the antenna **30** including its mounting brackets and associated hardware. This can be done to verify appropriate hardware installation, to verify the hardware is not loose or missing, and to verify that antenna **30** is plumb relative to the support bar **200**.

§ 5.3 Antenna Azimuth

In an exemplary aspect of the cell site audit **40**, the UAV **50** and/or the mobile device **100** can be used to verify the antenna azimuth, such as verifying the antenna azimuth is oriented within $\pm 5^\circ$ as defined on the RF data sheet. The azimuth (AZ) angle is the compass bearing, relative to true (geographic) north, of a point on the horizon directly beneath an observed object. Here, the UAV **50** and/or the mobile device **100** can include a location determining device such as a Global Positioning Satellite (GPS) measurement device. The antenna azimuth can be determined with the UAV **50** and/or the mobile device **100** using an aerial photo or the GPS measurement device.

§ 5.4 Photo Collections

As part of the cell site audit **40** generally, the UAV **50** and/or the mobile device **100** can be used to document various aspects of the cell site **10** by taking photos or video. For example, the mobile device **100** can be used to take photos or video on the ground in or around the shelter or cabinet **52** and the UAV **500** can be used to take photos or video up the cell tower **12** and of the cell site components **14**. The photos and video can be stored in any of the UAV **50**, the mobile device **100**, the cloud, etc.

In an exemplary embodiment, the UAV can also hover at the cell site **10** and provide real-time video footage back to the mobile device **100** or another location (for example, a Network Operations Center (NOC) or the like).

§ 5.5 Compound Length/Width

The UAV **50** can be used to fly over the cell site **10** to measure the overall length and width of the cell site **10** compound from overhead photos. In one aspect, the UAV **50** can use GPS positioning to detect the length and width by flying over the cell site **10**. In another aspect, the UAV **50** can take overhead photos which can be processed to determine the associated length and width of the cell site **10**.

§ 5.6 Data Capture—Cell Site Audit

The UAV **50** can be used to capture various pieces of data via the camera **86**. That is, with the UAV **50** and the mobile device **100**, the camera **86** is equivalent to the engineer/technician’s own eyes, thereby eliminating the need for the engineer/technician to physically climb the tower. One important aspect of the cell site audit **40** is physically collecting various pieces of information—either to check records for consistency or to establish a record. For example, the data capture can include determining equipment module types, locations, connectivity, serial numbers, etc. from photos. The data capture can include determining physical dimensions from photos or from GPS such as the cell tower **12** height, width, depth, etc. The data capture can also include visual inspection of any aspect of the cell site **10**, cell tower **12**, cell site components **14**, etc. including, but not limited to, physical characteristics, mechanical connectivity, cable connectivity, and the like.

The data capture can also include checking the lightning rod **16** and the warning light **18** on the cell tower **12**. Also, with additional equipment on the UAV **50**, the UAV **50** can be configured to perform maintenance such as replacing the warning light **18**, etc. The data capture can also include checking maintenance status of the cell site components **14** visually as well as checking associated connection status. Another aspect of the cell site audit **40** can include checking structural integrity of the cell tower **12** and the cell site components **14** via photos from the UAV **50**.

§ 5.7 Flying the UAV at the Cell Site

In an exemplary embodiment, the UAV **50** can be programmed to automatically fly to a location and remain there without requiring the operator to control the UAV **50** in real-time, at the cell site **10**. In this scenario, the UAV **50** can be stationary at a location in the air at the cell site **10**. Here, various functionality can be incorporated in the UAV **50** as described herein. Note, this aspect leverages the ability to fly the UAV **50** commercially based on the constraints described herein. That is, the UAV **50** can be used to fly around the cell tower **12**, to gather data associated with the cell site components **14** for the various sectors **54**, **56**, **58**. Also, the UAV **50** can be used to hover around the cell tower **12**, to provide additional functionality described as follows.

§ 5.8 Video/Photo Capture—Cell Site

With the UAV **50** available to operate at the cell site **10**, the UAV **50** can also be used to capture video/photos while hovering. This application uses the UAV **50** as a mobile video camera to capture activity at or around the cell site **10** from the air. It can be used to document work at the cell site **10** or to investigate the cell site **10** responsive to problems, e.g. tower collapse. It can be used to take surveillance video of surrounding locations such as service roads leading to the cell site **10**, etc.

§ 5.9 Wireless Service Via the UAV

Again, with the ability to fly at the cell site **10**, subject to the constraints, the UAV **50** can be used to provide temporary or even permanent wireless service at the cell site. This is performed with the addition of wireless service-related components to the UAV **50**. In the temporary mode, the UAV **50** can be used to provide service over a short time period, such as responding to an outage or other disaster affecting

the cell site 10. Here, an operator can cause the UAV 50 to fly where the cell site components 14 are and provide such service. The UAV 50 can be equipped with wireless antennas to provide cell service, Wireless Local Area Network (WLAN) service, or the like. The UAV 50 can effectively operate as a temporary tower or small cell as needed.

In the permanent mode, the UAV 50 (along with other UAVs 50) can constantly be in the air at the cell site 10 providing wireless service. This can be done similar to the temporary mode, but over a longer time period. The UAV 50 can be replaced over a predetermined time to refuel or the like. The replacement can be another UAV 50. The UAV 50 can effectively operate as a permanent tower or small cell as needed.

§ 6.0 Flying the UAV from Cell Site to Another Cell Site

As described herein, the flight constraints include operating the UAV 50 vertically in a defined 3D rectangle at the cell site 10. In another exemplary embodiment, the flight constraints can be expanded to allow the 3D rectangle at the cell site 10 as well as horizontal operation between adjacent cell sites 10. Referring to FIG. 7, in an exemplary embodiment, a network diagram illustrates various cell sites 10a-10e deployed in a geographic region 300. In an exemplary embodiment, the UAV 50 is configured to operate as described herein, such as in FIG. 2, in the vertical 3D rectangular flight pattern, as well as in a horizontal flight pattern between adjacent cell sites 10. Here, the UAV 50 is cleared to fly, without the commercial regulations, between the adjacent cell sites 10.

In this manner, the UAV 50 can be used to perform the cell site audits 40 at multiple locations—note, the UAV 50 does not need to land and physically be transported to the adjacent cell sites 10. Additionally, the fact that the FAA will allow exemptions to fly the UAV 50 at the cell site 10 and between adjacent cell sites 10 can create an interconnected mesh network of allowable flight paths for the UAV 50. Here, the UAV 50 can be used for other purposes besides those related to the cell site 10. That is, the UAV 50 can be flown in any application, independent of the cell sites 10, but without requiring FAA regulation. The applications can include, without limitation, a drone delivery network, a drone surveillance network, and the like.

As shown in FIG. 7, the UAV 50, at the cell site 10a, can be flown to any of the other cell sites 10b-10e along flight paths 302. Due to the fact that cell sites 10 are numerous and diversely deployed in the geographic region 300, an ability to fly the UAV 50 at the cell sites 10 and between adjacent cell sites 10 creates an opportunity to fly the UAV 50 across the geographic region 300, for numerous applications.

§ 7.0 UAV and Cell Towers

Additionally, the systems and methods describe herein contemplate practically any activity at the cell site 10 using the UAV 50 in lieu of a tower climb. This can include, without limitation, any tower audit work with the UAV 50, any tower warranty work with the UAV 50, any tower operational ready work with the UAV 50, any tower construction with the UAV 50, any tower decommissioning/deconstruction with the UAV 50, any tower modifications with the UAV 50, and the like.

§ 8.0 Tethered UAV Systems and Methods

Referring to FIGS. 8 and 9, in an exemplary embodiment, diagrams illustrate a cell site 10 for illustrating the UAV 50 and associated tethered UAV systems and methods. Specifically, FIGS. 8 and 9 is similar to FIG. 2, but here, the UAV 50 is tethered at or near the cell site 10 via a connection 400. The connection 400 can include a cable, a rope, a power cable, a communications cable, a fiber optic cable, etc., i.e.,

any connection with strength to constrain the UAV 50 to the cell site 10. In an exemplary embodiment in FIG. 8, the connection 400 is tethered to the top of the cell tower 12, such as at the cell site components 14 or at one of the alpha sector 54, beta sector 56, and gamma sector 58. In another exemplary embodiment in FIG. 8, the connection 400 is tethered to the cell tower 12 itself, such as at any point between the base and the top of the cell tower 12. In a further exemplary embodiment in FIG. 8, the connection 400 is tethered to the bottom of the cell site 10, such as at the shelter or cabinet 52 or a base of the cell tower 12. Specifically, in FIG. 8, the tethered configuration includes the connection 400 coupled to some part of the cell tower 12 or the like.

In FIG. 9, the tethered configuration includes the connection 400 coupled to something that is not part of the cell tower 12, such as a connection point 401, i.e., in FIG. 9, the UAV 50 is tethered at or near the cell site 10 and, in FIG. 8, the UAV 50 is tethered at the cell tower 12. In various exemplary embodiments, the connection point 401 can include, without limitation, a stake, a pole, a weight, a fence, a communications device, a wireless radio, a building or other structure, or any other device or object at or near the cell site 12. As described herein, the UAV 50 is in a tethered configuration where the UAV 50 is coupled at or near the cell site 10 via the connection 400.

In an exemplary embodiment, the UAV 50 can be housed or located at or near the cell site 10, connected via the connection 400, and stored in housings 402, 404, for example. The housings 402, 404 are shown for illustration purposes, and different locations are also contemplated. The housing 402 is on the cell tower 12, and the housing 404 is at or part of the shelter or cabinet 52. In operation, the UAV 50 is configured to selectively enter/exit the housing 402, 404. The connection 400 can be tethered to or near the housing 402, 404. The housing 402, 404 can include a door that selectively opens/closes. Alternatively, the housing 402, 404 includes an opening where the UAV 50 enters and exits. The housing 402, 404 can be used to store the UAV 50 while not in operation.

One unique aspect of the tethered configuration described herein, i.e., the UAV 50 with the connection 400, is that the UAV 50 can now be viewed as an attached device to the cell site 10, and not a free-flying drone. Advantageously, such a configuration can avoid airspace regulations or restrictions. Furthermore, with the connection 400 providing power and/or data connectivity, the UAV 50 contemplates extended periods of time for operation.

As costs decrease, it is feasible to deploy the UAV 50 with the connections 400 and optionally the housing 402, 404 at all cell sites 10. The UAV 50 with the connection 400 contemplates implementing all of the same functionality described herein with respect to FIGS. 1-6. Specifically, the UAV 50 with the connection 400 can be used to perform the cell site audit 40 and the like as well as other features. Also, the UAV 50 with the connection 400 is ideal to act as a wireless access point for wireless service. Here, the connection 400 can provide data and/or power, and be used for 1) additional capacity as needed or 2) a protection antenna to support active components in the cell site components 14 that fail. The UAV 50 with the connection 400 can be used to support overflow capacity as well as needed, providing LTE, WLAN, WiMAX, or any other wireless connectivity. Alternatively, the UAV 50 can be used as an alternative service provider to provide wireless access at the cell site 10 without requiring antennas on the cell tower 12.

Referring to FIG. 8, in an exemplary embodiment, a flowchart illustrates a method 500 with a tethered Unmanned Aerial Vehicle (UAV) associated with a cell site. The method 500 includes causing the UAV to fly at or near the cell site while the UAV is tethered at or near the cell site via a connection, wherein flight of the UAV at or near the cell site is constrained based on the connection (step 502); and performing one or more functions via the UAV at or near the cell site while the UAV is flying tethered at or near the cell site (step 504).

The method 500 can further include transferring power and/or data to and from the UAV via the connection (step 506). The connection can include one or more of a cable, a rope, a power cable, a communications cable, and a fiber optic cable. The one or more functions can include functions related to a cell site audit. The one or more functions can include functions related to providing wireless service via the UAV at the cell site, wherein data and/or power is transferred between the UAV and the cell site to perform the wireless service. The one or more functions can include providing visual air traffic control via one or more cameras on the UAV. The method 500 can further include storing the UAV at the cell site in a housing while the UAV is not in use. The UAV can be configured to fly extended periods at the cell site utilizing power from the connection, where the extended periods are longer than if the UAV did not have power from the connection. The connection can be configured to constrain a flight path of the UAV at the cell site.

In another exemplary embodiment, a tethered Unmanned Aerial Vehicle (UAV) associated with a cell site includes one or more rotors disposed to a body, wherein the body is tethered to the cell site via a connection; a camera associated with the body; wireless interfaces; a processor coupled to the wireless interfaces and the camera; and memory storing instructions that, when executed, cause the processor to: process commands to cause the one or more rotors to fly the UAV at the cell site while the UAV is tethered to the cell site via the connection, wherein flight of the UAV at the cell site is constrained based on the connection; and perform one or more functions via the UAV at the cell site while the UAV is flying tethered to the cell site, utilizing one or more of the camera and the wireless interfaces.

§ 8.1 Tethered UAV Systems and Methods—Visual Air Traffic Control

In an exemplary embodiment, the tethered UAV 50 can be configured to provide visual air traffic control such as for other UAVs or drones. Here, various tethered UAVs 50 can be deployed across a geographic region at various cell sites 10 and each UAV 50 can have one or more cameras that can provide a 360 degree view around the cell site 10. This configuration essentially creates a drone air traffic control system that could be monitored and controlled by Network Control Center (NOC). Specifically, the UAV 50 can be communicatively coupled to the NOC, such as via the connection 400. The NOC can provide the video feeds of other drones to third parties (e.g., Amazon) and other drone users to comply with current FAA regulations that require eyes on drones at all times.

§ 9.0 UAV Systems and Methods Using Robotic Arms or the Like

Referring to FIGS. 11 and 12, in an exemplary embodiment, diagrams illustrate a cell site 10 for illustrating the UAV 50 and associated UAV systems and methods with robotic arms for performing operations associated with the cell site components 14. Specifically, FIGS. 11 and 12 is similar to FIG. 2 (and FIGS. 8 and 9), but here, the UAV 50 is equipped with one or more robotic arms 600 for carrying

payload 602 and/or performing operations associated with the cell site components 14 on the cell tower 12. Since the robotic arms 600 and the payload 602 add weight and complexity when maneuvering, the systems and methods include a connection 604 between the UAV 50 and the cell tower 12 which physically supports the UAV 50 at the cell site components 14. In this manner, there are no counterbalance requirements for the UAV 50 for the robotic arms 600 and the payload 602. In another exemplary embodiment, the connection 604 can also provide power to the UAV 50 in addition to physically supporting the UAV 50. That is, the connection 604 is adapted to provide power to the UAV 50 when connected thereto. Specifically, the robotic arms 600 could require a large amount of power, which can come from a power source connected through the connection 604 to the UAV. In an exemplary embodiment, the UAV 50, once physically connected to the connection 604, can shut off the flight and local power components and operate the robotic arms 600 via power from the connection 604.

In another exemplary embodiment, the UAV 50 with the robotic arms 600 can utilize the tethered configuration where the UAV 50 is coupled at or near the cell site 10 via the connection 400. Here, the UAV 50 can use both the connection 400 for a tether and the connection 604 for physical support/stability when at the cell tower 12 where operations are needed. Here, the connection 400 can be configured to provide power to the UAV 50 as well. The UAV 50 can also fly up the connection 400 from the ground that supplies power and any other functions such as a video feed up or down. The tethered UAV 500 attaches itself to the cell tower 12 via the connection 604, shuts off rotors, engages the robotic arms 600 and then does work, but in this case the power for those robotic arms 600 as well as the rotors comes from a power feed in the connection 400 that is going down to the ground. The UAV 50 also may or may not have a battery and it may or may not be used.

The UAV 50 with the robotic arms 600 is configured to fly up the cell tower 12, with or without the payload 602. For example, with the payload 602, the UAV 50 can be used to bring components to the cell site components 14, flying up the cell tower 12. Without the payload 602, the UAV 50 is flown to the top with the robotic arms 600 for performing operations on the cell tower 12 and the cell site components 14. In both cases, the UAV 50 is configured to fly up the cell tower 12, including using all of the constraints described herein. During flight, the UAV 50 with the robotic arms 600 and with or without the payload 602 does not have a counterbalance issue because the robotic arms 600 and the payload 602 are fixed, i.e., stationary. That is, the UAV 50 flies without movement of the robotic arms 600 or the payload 603 during the flight.

Once the UAV 50 reaches a desired location on the cell tower 12, the UAV 50 is configured to physically connect via the connection 604 to the cell tower 12, the cell site components 14, or the like. Specifically, via the connection 604, the UAV 50 is configured to be physically supported without the rotors 80 or the like operating. That is, via the connection 604, the UAV 50 is physically supporting without flying, thereby eliminating the counterbalancing problems. Once the connection 604 is established and the UAV 50 flight components are disengaged, the robotic arms 600 and the payload 602 can be moved, manipulated, etc. without having balancing problems that have to be compensated by the flight components. This is because the connection 604 bears the weight of the UAV 50, allowing any movement by the robotic arms 600 and/or the payload 602.

In an exemplary embodiment, the connection **604** includes a grappling arm that extends from the UAV **50** and physically attaches to the cell tower **12**, such as a grappling hook or the like. In another exemplary embodiment, the connection **604** includes an arm located on the cell tower **12** that physically connects to a connection point in the UAV **50**. Of course, the systems and methods contemplate various connection techniques for the connection **604**. The connection **604** has to be strong enough to support the weight of the UAV **50**, the robotic arms **600**, and the payload **602**.

In an exemplary embodiment, the UAV **50** can carry the payload **602** up the cell tower **12**. The payload **602** can include wireless components, cables, nuts/bolts, antennas, supports, braces, lighting rods, lighting, electronics, RF equipment, combinations thereof, and the like. That is, the payload **602** can be anything associated with the cell site components **14**. With the robotic arms **600**, the UAV **500** can be used to perform operations associated with the payload **602**. The operations can include, without limitation, installing cables, installing nuts/bolts to structures or components, installing antennas, installing supports or braces, installing lighting rods, installing electronic or RF equipment, etc.

In another exemplary embodiment, the UAV **50** does not include the payload **602** and instead uses the robotic arms **600** to perform operations on existing cell site components **14**. Here, the UAV **50** is flown up the cell site **12** and connected to the connection **604**. Once connected and the flight components disengaged, the UAV **50** can include manipulation of the robotic arms **600** to perform operations on the cell site components **14**. The operations can include, without limitation, manipulating cables, removing/tightening nuts/bolts to structures or components, adjusting antennas, adjusting lighting rods, replacing bulbs in lighting, opening/closing electronic or RF equipment, etc.

Referring to FIG. **13**, in an exemplary embodiment, a flowchart illustrates a method **700** with a UAV with robotic arms at a cell site. The method **700** contemplates operation with the UAV **50** with the robotic arms **600** and optionally with the payload **602**. The method **700** includes causing the UAV to fly at or near the cell site, wherein the UAV includes one or more manipulable arms which are stationary during flight (step **702**); physically connecting the UAV to a structure at the cell site and disengaging flight components associated with the UAV (step **704**); and performing one or more functions via the one or more manipulable arms while the UAV is physically connected to the structure, wherein the one or more manipulable arms move while the UAV is physically connected to the structure (step **706**). The method **700** can further include utilizing the one or more manipulable arms to provide payload to a cell tower at the cell site, wherein the payload is stationary in the one or more manipulable arms during flight (step **708**). The payload can include any of wireless components, cables, nuts/bolts, antennas, supports, braces, lighting rods, lighting, electronics, and combinations thereof. The method **700** can further include utilizing the one or more manipulable arms to perform operations on a cell tower at the cell site (step **710**). The operations can include any of installing wireless components, installing cables, installing nuts/bolts, installing antennas, installing supports, installing braces, installing lighting rods, installing lighting, installing electronics, and combinations thereof. The physically connecting can include extending a grappling arm from the UAV to attach to the structure. The physically connecting can include connecting the UAV to an arm extending from the structure which is connectable to the UAV. The physically connecting can be via a connection which bears weight of the UAV,

enabling movement of the one or more manipulable arms without requiring counterbalancing of the UAV due to the movement while the UAV is in flight.

§ 10.0 Cell Site Operations

There are generally two entities associated with cell sites—cell site owners and cell site operators. Generally, cell site owners can be viewed as real estate property owners and managers. Typical cell site owners may have a vast number of cell sites, such as tens of thousands, geographically dispersed. The cell site owners are generally responsible for the real estate, ingress and egress, structures on site, the cell tower itself, etc. Cell site operators generally include wireless service providers who generally lease space on the cell tower and in the structures for antennas and associated wireless backhaul equipment. There are other entities that may be associated with cell sites as well including engineering firms, installation contractors, and the like. All of these entities have a need for the various UAV-based systems and methods described herein. Specifically, cell site owners can use the systems and methods for real estate management functions, audit functions, etc. Cell site operators can use the systems and methods for equipment audits, troubleshooting, site engineering, etc. Of course, the systems and methods described herein can be provided by an engineering firm or the like contracted to any of the above entities or the like. The systems and methods described herein provide these entities time savings, increased safety, better accuracy, lower cost, and the like.

§ 11.0 3D Modeling Systems and Methods with UAVs

Referring to FIG. **14**, in an exemplary embodiment, a diagram illustrates the cell site **10** and an associated launch configuration and flight for the UAV **50** to obtain photos for a 3D model of the cell site **10**. Again, the cell site **10**, the cell tower **12**, the cell site components **14**, etc. are as described herein. To develop a 3D model, the UAV **50** is configured to take various photos during flight, at different angles, orientations, heights, etc. to develop a 360 degree view. For post processing, it is important to accurately differentiate between different photos. In various exemplary embodiments, the systems and methods utilize accurate location tracking for each photo taken. It is important for accurate correlation between photos to enable construction of a 3D model from a plurality of 2D photos. The photos can all include multiple location identifiers (i.e., where the photo was taken from, height and exact location). In an exemplary embodiment, the photos can each include at least two distinct location identifiers, such as from GPS or GLO-NASS. GLO-NASS is a “GLObal NAVigation Satellite System” which is a space-based satellite navigation system operating in the radionavigation-satellite service and used by the Russian Aerospace Defence Forces. It provides an alternative to GPS and is the second alternative navigational system in operation with global coverage and of comparable precision. The location identifiers are tagged or embedded to each photo and indicative of the location of the UAV **50** where and when the photo was taken. These location identifiers are used with objects of interest identified in the photo during post processing to create the 3D model.

In fact, it was determined that location identifier accuracy is very important in the post processing for creating the 3D model. One such determination was that there are slight inaccuracies in the location identifiers when the UAV **50** is launched from a different location and/or orientation. Thus, to provide further accuracy for the location identifiers, each flight of the UAV **50** is constrained to land and depart from a same location and orientation. For example, future flights of the same cell site **10** or additional flights at the same time

when the UAV 50 lands and, e.g., has a battery change. To ensure the same location and/or orientation in subsequent flights at the cell site 10, a zone indicator 800 is set at the cell site 10, such as on the ground via some marking (e.g., chalk, rope, white powder, etc.). Each flight at the cell site 10 for purposes of obtaining photos for 3D modeling is done using the zone indicator 800 to land and launch the UAV 50. Based on operations, it was determined that using conventional UAVs 50, the zone indicator 800 provides significant more accuracy in location identifier readings. Accordingly, the photos are accurately identified relative to one another and able to create an extremely accurate 3D model of all physical features of the cell site 10. Thus, in an exemplary embodiment, all UAV 50 flights are from a same launch point and orientation to avoid calibration issues with any location identifier technique. The zone indicator 800 can also be marked on the 3D model for future flights at the cell site 10. Thus, the use of the zone indicator 800 for the same launch location and orientation along with the multiple location indicators provide more precision in the coordinates for the UAV 50 to correlate the photos.

Note, in other exemplary embodiments, the zone indicator 800 may be omitted or the UAV 50 can launch from additional points, such that the data used for the 3D model is only based on a single flight. The zone indicator 800 is advantageous when data is collected over time or when there are landings in a flight.

Once the zone indicator 800 is established, the UAV 50 is placed therein in a specific orientation (orientation is arbitrary so long as the same orientation is continually maintained). The orientation refers to which way the UAV 50 is facing at launch and landing. Once the UAV 50 is in the zone indicator 800, the UAV 50 can be flown up (denoted by line 802) the cell tower 12. Note, the UAV 50 can use the aforementioned flight constraints to conform to FAA regulations or exemptions. Once at a certain height and certain distance from the cell tower 12 and the cell site components 14, the UAV 50 can take a circular or 360 degree flight pattern about the cell tower 12, including flying up as well as around the cell tower 12 (denoted by line 804).

During the flight, the UAV 50 is configured to take various photos of different aspects of the cell site 10 including the cell tower 12, the cell site components 14, as well as surrounding area. These photos are each tagged or embedded with multiple location identifiers. It has also been determined that the UAV 50 should be flown at a certain distance based on its camera capabilities to obtain the optimal photos, i.e., not too close or too far from objects of interest. The UAV 50 in a given flight can take hundreds or even thousands of photos, each with the appropriate location identifiers. For an accurate 3D model, at least hundreds of photos are required. The UAV 50 can be configured to automatically take pictures at given intervals during the flight and the flight can be a preprogrammed trajectory around the cell site 10. Alternatively, the photos can be manually taken based on operator commands. Of course, a combination is also contemplated. In another exemplary embodiment, the UAV 50 can include preprocessing capabilities which monitor photos taken to determine a threshold after which enough photos have been taken to accurately construct the 3D model.

Referring to FIG. 15, in an exemplary embodiment, a satellite view illustrates an exemplary flight of the UAV 50 at the cell site 10. Note, photos are taken at locations marked with circles in the satellite view. Note, the flight of the UAV 50 can be solely to construct the 3D model or as part of the cell site audit 40 described herein. Also note, the exemplary

flight allows photos at different locations, angles, orientations, etc. such that the 3D model not only includes the cell tower 12, but also the surrounding geography.

Referring to FIG. 16, in an exemplary embodiment, a side view illustrates an exemplary flight of the UAV 50 at the cell site 10. Similar to FIG. 15, FIG. 16 shows circles in the side view at locations where photos were taken. Note, photos are taken at different elevations, orientations, angles, and locations.

The photos are stored locally in the UAV 50 and/or transmitted wirelessly to a mobile device, controller, server, etc. Once the flight is complete and the photos are provided to an external device from the UAV 50 (e.g., mobile device, controller, server, cloud service, or the like), post processing occurs to combine the photos or "stitch" them together to construct the 3D model. While described separately, the post processing could occur in the UAV 50 provided its computing power is capable.

Referring to FIG. 17, in an exemplary embodiment, a logical diagram illustrates a portion of a cell tower 12 along with associated photos taken by the UAV 50 at different points relative thereto. Specifically, various 2D photos are logically shown at different locations relative to the cell tower 12 to illustrate the location identifiers and the stitching together of the photos.

Referring to FIG. 18, in an exemplary embodiment, a screen shot illustrates a Graphic User Interface (GUI) associated with post processing photos from the UAV 50. Again, once the UAV 50 has completed taking photos of the cell site 10, the photos are post processed to form a 3D model. The systems and methods contemplate any software program capable of performing photogrammetry. In the example of FIG. 18, there are 128 total photos. The post processing includes identifying visible points across the multiple points, i.e., objects of interest. For example, the objects of interest can be any of the cell site components 14, such as antennas. The post processing identifies the same object of interest across different photos, with their corresponding location identifiers, and builds a 3D model based on multiple 2D photos.

Referring to FIG. 19, in an exemplary embodiment, a screen shot illustrates a 3D model constructed from a plurality of 2D photos taken from the UAV 50 as described herein. Note, the 3D model can be displayed on a computer or another type of processing device, such as via an application, a Web browser, or the like. The 3D model supports zoom, pan, tilt, etc.

Referring to FIGS. 20-25, in various exemplary embodiments, various screen shots illustrate GUIs associated with a 3D model of a cell site based on photos taken from the UAV 50 as described herein. FIG. 20 is a GUI illustrating an exemplary measurement of an object, i.e., the cell tower 12, in the 3D model. Specifically, using a point and click operation, one can click on two points such as the top and bottom of the cell tower and the 3D model can provide a measurement, e.g. 175' in this example. FIG. 21 illustrates a close up view of a cell site component 14 such as an antenna and a similar measurement made thereon using point and click, e.g. 4.55' in this example. FIGS. 22 and 23 illustrate an aerial view in the 3D model showing surrounding geography around the cell site 10. From these views, the cell tower 12 is illustrated with the surrounding environment including the structures, access road, fall line, etc. Specifically, the 3D model can assist in determining a fall line which is anywhere in the surroundings of the cell site 10 where the cell tower 12 may fall. Appropriate considerations can be made based thereon.

FIGS. 24 and 25 illustrate the 3D model and associated photos on the right side. One useful aspect of the 3D model GUI is an ability to click anywhere on the 3D model and bring up corresponding 2D photos. Here, an operator can click anywhere and bring up full sized photos of the area. Thus, with the systems and methods described herein, the 3D model can measure and map the cell site 10 and surrounding geography along with the cell tower 12, the cell site components 14, etc. to form a comprehensive 3D model. There are various uses of the 3D model to perform cell site audits including checking tower grounding; sizing and placement of antennas, piping, and other cell site components 14; providing engineering drawings; determining characteristics such as antenna azimuths; and the like.

Referring to FIG. 26, in an exemplary embodiment, a photo illustrates the UAV 50 in flight at the top of a cell tower 12. As described herein, it was determined that the optimum distance to photograph the cell site components 14 is about 10' to 40' distance.

Referring to FIG. 27, in an exemplary embodiment, a flowchart illustrates a process 850 for modeling a cell site with an Unmanned Aerial Vehicle (UAV). The process 850 includes causing the UAV to fly a given flight path about a cell tower at the cell site, wherein a launch location and launch orientation is defined for the UAV to take off and land at the cell site such that each flight at the cell site has the same launch location and launch orientation (step 852); obtaining a plurality of photographs of the cell site during about the flight plane, wherein each of the plurality of photographs is associated with one or more location identifiers (step 854); and, subsequent to the obtaining, processing the plurality of photographs to define a three dimensional (3D) model of the cell site based on the associated with one or more location identifiers and one or more objects of interest in the plurality of photographs (step 856).

The process 850 can further include landing the UAV at the launch location in the launch orientation; performing one or more operations on the UAV, such as changing a battery; and relaunching the UAV from the launch location in the launch orientation to obtain additional photographs. The one or more location identifiers can include at least two location identifiers including Global Positioning Satellite (GPS) and GLObal NAvigation Satellite System (GLONASS). The flight plane can be constrained to an optimum distance from the cell tower. The plurality of photographs can be obtained automatically during the flight plan while concurrently performing a cell site audit of the cell site. The process 850 can further include providing a graphical user interface (GUI) of the 3D model; and using the GUI to perform a cell site audit. The process 850 can further include providing a graphical user interface (GUI) of the 3D model; and using the GUI to measure various components at the cell site. The process 850 can further include providing a graphical user interface (GUI) of the 3D model; and using the GUI to obtain photographs of the various components at the cell site.

§ 11.1 3D Modeling Systems and Methods without UAVs

The above description explains 3D modeling and photo data capture using the UAV 50. Additionally, the photo data capture can be through other means, including portable cameras, fixed cameras, heads up displays (HUD), head mounted cameras, and the like. That is, the systems and methods described herein contemplate the data capture through any available technique. The UAV 50 will be difficult to obtain photos inside the buildings, i.e., the shelter or cabinet 52. Referring to FIG. 28, in an exemplary embodiment, a diagram illustrates an exemplary interior 900 of a building 902, such as the shelter or cabinet 52, at the cell

site 10. Generally, the building 902 houses equipment associated with the cell site 10 such as wireless RF terminals 910 (e.g., LTE terminals), wireless backhaul equipment 912, power distribution 914, and the like. Generally, wireless RF terminals 910 connect to the cell site components 14 for providing associated wireless service. The wireless backhaul equipment 912 includes networking equipment to bring the associated wireless service signals to a wireline network, such as via fiber optics or the like. The power distribution 914 provides power for all of the equipment such as from the grid as well as battery backup to enable operation in the event of power failures. Of course, additional equipment and functionality is contemplated in the interior 900.

The terminals 910, equipment 912, and the power distribution 914 can be realized as rack or frame mounted hardware with cabling 916 and with associated modules 918. The modules 918 can be pluggable modules which are selectively inserted in the hardware and each can include unique identifiers 920 such as barcodes, Quick Response (QR) codes, RF Identification (RFID), physical labeling, color coding, or the like. Each module 918 can be unique with a serial number, part number, and/or functional identifier. The modules 918 are configured as needed to provide the associated functionality of the cell site.

The systems and methods include, in addition to the aforementioned photo capture via the UAV 50, photo data capture in the interior 900 for 3D modeling and for virtual site surveys. The photo data capture can be performed by a fixed, rotatable camera 930 located in the interior 900. The camera 930 can be communicatively coupled to a Data Communication Network (DCN), such as through the wireless backhaul equipment 912 or the like. The camera 930 can be remotely controlled, such as by an engineer performing a site survey from his or her office. Other techniques of photo data capture can include an on-site technician taking photos with a camera and uploading them to a cloud service or the like. Again, the systems and methods contemplate any type of data capture.

Again, with a plurality of photos, e.g., hundreds, it is possible to utilize photogrammetry to create a 3D model of the interior 900 (as well as a 3D model of the exterior as described above). The 3D model is created using physical cues in the photos to identify objects of interest, such as the modules 918, the unique identifiers 920, or the like. Note, the location identifiers described relative to the UAV 50 are less effective in the interior 900 given the enclosed, interior space and the closer distances.

§ 12.0 Virtual Site Survey

Referring to FIG. 29, in an exemplary embodiment, a flowchart illustrates a virtual site survey process 950 for the cell site 10. The virtual site survey process 950 is associated with the cell site 10 and utilizes three-dimensional (3D) models for remote performance, i.e., at an office as opposed to in the field. The virtual site survey process 950 includes obtaining a plurality of photographs of a cell site including a cell tower and one or more buildings and interiors thereof (step 952); subsequent to the obtaining, processing the plurality of photographs to define a three dimensional (3D) model of the cell site based on one or more objects of interest in the plurality of photographs (step 954); and remotely performing a site survey of the cell site utilizing a Graphical User Interface (GUI) of the 3D model to collect and obtain information about the cell site, the cell tower, the one or more buildings, and the interiors thereof (step 956). The 3D model is a combination of an exterior of the cell site including the cell tower and associated cell site components thereon, geography local to the cell site, and the interiors of

the one or more buildings at the cell site, and the 3D model can include detail at a module level in the interiors.

The remotely performing the site survey can include determining equipment location on the cell tower and in the interiors; measuring distances between the equipment and within the equipment to determine actual spatial location; and determining connectivity between the equipment based on associated cabling. The remotely performing the site survey can include planning for one or more of new equipment and changes to existing equipment at the cell site through drag and drop operations in the GUI, wherein the GUI includes a library of equipment for the drag and drop operations; and, subsequent to the planning, providing a list of the one or more of the new equipment and the changes to the existing equipment based on the library, for implementation thereof. The remotely performing the site survey can include providing one or more of the photographs of an associated area of the 3D model responsive to an operation in the GUI. The virtual site survey process 950 can include rendering a texture map of the interiors responsive to an operation in the GUI.

The virtual site survey process 950 can include performing an inventory of equipment at the cell site including cell site components on the cell tower and networking equipment in the interiors, wherein the inventory from the 3D model uniquely identifies each of the equipment based on associated unique identifiers. The remotely performing the site survey can include providing an equipment visual in the GUI of a rack and all associated modules therein. The obtaining can include the UAV 50 obtaining the photographs on the cell tower and the obtaining includes one or more of a fixed and portable camera obtaining the photographs in the interior. The obtaining can be performed by an on-site technician at the cell site and the site survey can be remotely performed.

In another exemplary embodiment, an apparatus adapted to perform a virtual site survey of a cell site utilizing three-dimensional (3D) models for remote performance includes a network interface and a processor communicatively coupled to one another; and memory storing instructions that, when executed, cause the processor to receive, via the network interface, a plurality of photographs of a cell site including a cell tower and one or more buildings and interiors thereof process the plurality of photographs to define a three dimensional (3D) model of the cell site based on one or more objects of interest in the plurality of photographs, subsequent to receiving the photographs; and provide a Graphical User Interface of the 3D model for remote performance of a site survey of the cell site utilizing the 3D model to collect and obtain information about the cell site, the cell tower, the one or more buildings, and the interiors thereof.

In a further exemplary embodiment, a non-transitory computer readable medium includes instructions that, when executed, cause one or more processors to perform the steps of: receiving a plurality of photographs of a cell site including a cell tower and one or more buildings and interiors thereof processing the plurality of photographs to define a three dimensional (3D) model of the cell site based on one or more objects of interest in the plurality of photographs, subsequent to receiving the photographs; and rendering a Graphical User Interface of the 3D model for remote performance of a site survey of the cell site utilizing the 3D model to collect and obtain information about the cell site, the cell tower, the one or more buildings, and the interiors thereof.

The virtual site survey can perform anything remotely that traditionally would have required on-site presence, including the various aspects of the cell site audit 40 described herein. The GUI of the 3D model can be used to check plumbing of coaxial cabling, connectivity of all cabling, automatic identification of cabling endpoints such as through unique identifiers detected on the cabling, and the like. The GUI can further be used to check power plant and batteries, power panels, physical hardware, grounding, heating and air conditioning, generators, safety equipment, and the like.

The 3D model can be utilized to automatically provide engineering drawings, such as responsive to the planning for new equipment or changes to existing equipment. Here, the GUI can have a library of equipment (e.g., approved equipment and vendor information can be periodically imported into the GUI). Normal drag and drop operations in the GUI can be used for equipment placement from the library. Also, the GUI system can include error checking, e.g., a particular piece of equipment is incompatible with placement or in violation of policies, and the like.

§ 13.0 UAV Configuration for Wireless Testing

Referring to FIG. 30, in an exemplary embodiment, a block diagram illustrates functional components associated with the UAV 50 to support wireless coverage testing. Specifically, the UAV 50 can include a processing device 1000, one or more wireless antennas 1002, a GPS and/or GLONASS location device 1004, one or more scanners 1006, WIFI 1008, and one or more mobile devices 1010. The processing device 1000 can include a similar architecture as the mobile device 100 described herein and can generally be used for control of the UAV 50 as well as control of the wireless coverage testing. The one or more wireless antennas 1002 can be configured to operate at any operating band using any wireless protocol (GSM, CDMA, UMTS, LTE, etc.). The one or more wireless antennas 1002 can be communicatively coupled to the processing device 1000 for control and measurement thereof. The location device 1004 is configured to denote a specific location of the UAV 50 at a specific time and can be communicatively coupled to the processing device 1000. The location device 1004 can collect latitude and longitude of each point as well as elevation. With this location information, the processing device 1000 can correlate measurement data, time, speed, etc. with location. The location information can also be used to provide feedback for the correct route of the UAV 50, during the wireless coverage testing and during general operation.

The one or more scanners 1006 are configured to collect measurement data in a broad manner, across the wireless network. The scanners 1006 can collect data that is not seen by the mobile devices 1010. The WIFI 1008 can be used to collect wireless coverage data related to Wireless Local Area Networks (WLANs), such as based on IEEE 802.11 and variants thereof. Note, some cell sites 10 additionally provide WLAN coverage, such as for public access WIFI or for airplane WIFI access. Finally, the mobile devices 1010 are physical mobile phones or emulation thereof, and can be used to collect measurement data based on what a mobile device 1010 would see.

Thus, the processing device 1000 provides centralized control and management. The location device 1004 collects a specific data point—location at a specific time. Finally, the antennas 1002, the one or more scanners 1006, the WIFI 1008, and the one or more mobile devices 1010 are measurement collection devices. Note, in various exemplary embodiments, the UAV 50 can include a combination of one

or more of the antennas **1002**, the one or more scanners **1006**, the WIFI **1008**, i.e., a practical embodiment does not require all of these devices.

The UAV **50** body can be configured with the antennas **1002**, the one or more scanners **1006**, the WIFI **1008**, and the one or more mobile devices **1010** such that there is distance between these devices to avoid electromagnetic interference or distortion of the radiation pattern of each that can affect measurements. In an exemplary embodiment, the antennas **1002**, the one or more scanners **1006**, the WIFI **1008**, and the one or more mobile devices **1010** are positioned on the UAV **50** with a minimum spacing between each, such as about a foot. In an exemplary embodiment, the UAV **50** is specifically designed to perform wireless coverage testing. For example, the UAV **50** can include a long bar underneath with the associated devices, the antennas **1002**, the one or more scanners **1006**, the WIFI **1008**, and the one or more mobile devices **1010**, disposed thereon with the minimum spacing.

§ 13.1 Conventional Drive Testing

Referring to FIG. **31**, in an exemplary embodiment, a map illustrates three cell towers **12** and associated coverage areas **1050**, **1052**, **1054** for describing conventional drive testing. Typically, for a cell site **10**, in rural locations, the coverage areas **1050**, **1052**, **1054** can be about 5 miles in radius whereas, in urban locations, the coverage areas **1050**, **1052**, **1054** can be about 0.5 to 2 miles in radius. For a conventional drive test, a vehicle drives a specific route **1056**. Of course, the route **1056** requires physical access, i.e., roads. Alternatively, the drive test can be walked. Of course, this conventional approach is inefficient and only provides measurements on the ground.

§ 13.2 UAV-Based Wireless Coverage Testing

Referring to FIG. **32**, in an exemplary embodiment, a 3D view illustrates a cell tower **12** with an associated coverage area **1060** in three dimensions—x, y, and z for illustrating UAV-based wireless coverage testing. The UAV **50**, with the configuration described in FIG. **30**, can be flown about the coverage area **1060** taking measurements along the way on a route **1062**. Specifically, the coverage area **1060** also includes an elevation **1064**, i.e., the z-axis. The UAV **50** has the advantage over the conventional drive test in that it is not constrained to a specific route on the ground, but can fly anywhere about the coverage area **1060**. Also, the UAV **50** can obtain measurements much quicker as a UAV flight is significantly faster than driving. Further, the UAV **50** can also perform testing of adjacent cell towers **12** in a same flight, flying to different coverage areas. For example, the UAV **50** can also measure overlapping regions between cell sites **12** for handoffs, etc. Thus, the UAV **50** has significant advantages over the conventional drive testing.

In an exemplary embodiment, the elevation **1064** can be up to 1000' or up to 500', providing coverage of areas at elevations the UAVs **50** intend to fly. In an exemplary embodiment, the route **1062** can include a circle about the cell tower **12**. In another exemplary embodiment, the route **1062** can include circles of varying elevations about the cell tower **12**. In a further exemplary embodiment, the route **1062** can include a path to cover the majority of the area within the coverage area **1060**, using an optimal flight path therein. The UAV **50** can perform the wireless coverage testing at any time of day—at night, for example, to measure activities related to system design or during the day to measure performance and maintenance with an active network.

The wireless coverage testing with the UAV **50** configuration in FIG. **30** can perform various functions to measure: Signal intensity, Signal quality, Interference, Dropped calls,

Blocked calls, Anomalous events, Call statistics, Service level statistics, Quality of Service (QoS) information, Handover information, Neighboring cell information, and the like. The wireless coverage testing can be used for network benchmarking, optimization and troubleshooting, and quality monitoring.

For benchmarking, sophisticated multi-channel tools can be used to measure several network technologies and service types simultaneously to very high accuracy, to provide directly comparable information regarding competitive strengths and weaknesses. Results from benchmarking activities, such a comparative coverage analysis or comparative data network speed analysis, are frequently used in marketing campaigns. Optimization and troubleshooting information is more typically used to aid in finding specific problems during the rollout phases of new networks or to observe specific problems reported by users during the operational phase of the network lifecycle. In this mode, the wireless testing data is used to diagnose the root cause of specific, typically localized, network issues such as dropped calls or missing neighbor cell assignments.

Service quality monitoring typically involves making test calls across the network to a fixed test unit to assess the relative quality of various services using Mean opinion score (MOS). Quality monitoring focuses on the end user experience of the service, and allows mobile network operators to react to what effectively subjective quality degradations by investigating the technical cause of the problem in time-correlated data collected during the drive test. Service quality monitoring is typically carried out in an automated fashion by the UAV **50**.

Once the UAV **50** starts the route **1062** and acquires location information, the wireless coverage testing process begins. Again, the UAV **50** can use two different location identifiers, e.g., GPS and GLONASS, to provide improved accuracy for the location. Also, the UAV **50** can perform subsequent tests from a same launch point and orientation as described herein. During the flight on the route **1062**, the UAV **50** obtains measurements from the various wireless measurement devices, i.e., the antennas **1002**, the one or more scanners **1006**, the WIFI **1008**, and the one or more mobile devices **1010**, and denotes such measurements with time and location identifiers.

The UAV **50** is configured based on the associated protocols and operating bands of the cell tower **12**. In an exemplary embodiment, the UAV **50** can be configured with two of the mobile devices **1010**. One mobile device **1010** can be configured with a test call during the duration of the flight, collecting measurements associated with the call during flight on the route **1062**. The other mobile device **1010** can be in a free or IDLE mode, collecting associated measurements during flight on the route **1062**. The mobile device **1010** making the call can perform short calls, such as 180 seconds to check if calls are established and successfully completed as well as long calls to check handovers between cell towers **12**.

Subsequent to the wireless coverage testing process, the collected measurement data can be analyzed and processed by various software tools. The software tools are configured to process the collected measurement data to provide reports and output files. Each post-processing software has its specific analysis, and as the collected measurement data is large, they can be of great help to solve very specific problems. These tools present the data in tables, maps and comparison charts that help in making decisions.

§ 13.3 UAV-Based Wireless Coverage Testing—Aerial Results

The wireless coverage testing with the UAV **50** enables a new measurement—wireless coverage above the ground. As described herein, cell towers **12** can be used for control of UAVs **50**, using the wireless network. Accordingly, the wireless coverage testing is useful in identifying coverage gaps not only on the ground where users typically access the wireless network, but also in the sky, such as up to 500 or 1000' where UAVs **50** will fly and need wireless coverage.

§ 13.4 UAV-Based Wireless Coverage Testing Process

Referring to FIG. **33**, in an exemplary embodiment, a flowchart illustrates a UAV-based wireless coverage testing process **1080**. The UAV-based wireless coverage testing process **1080** includes, with a UAV including a wireless coverage testing configuration, flying the UAV in a route in a wireless coverage area associated with a cell tower (step **1082**); collecting measurement data via the wireless coverage testing configuration during the flying and associating the collected measurement data with location identifiers (step **1084**); and, subsequent to the flying, processing the collected measurement data with the location identifiers to provide an output detailing wireless coverage in the wireless coverage area including wireless coverage at ground level and above ground level to a set elevation (step **1086**). The wireless coverage testing configuration can include one or more devices including any of wireless antennas, wireless scanners, Wireless Local Area Network (WLAN) antennas, and one or more mobile devices, communicatively coupled to a processing device, and each of the one or more devices disposed in or on the UAV. Each of the one or more devices can be positioned a minimum distance from one another to prevent interference, such as one foot. The UAV **50** can include a frame disposed thereto with the one or more devices attached thereto with a minimum distance from one another to prevent interference. The location identifiers can include at least two independent location identification techniques thereby improving accuracy thereof, such as GPS and GLONASS. Each subsequent of the flying steps for additional wireless coverage testing can be performed with the UAV taking off and landing at a same location and orientation at a cell site associated with the cell tower. The route can include a substantially circular pattern at a fixed elevation about the cell tower or a substantially circular pattern at a varying elevations about the cell tower.

The wireless coverage testing configuration can be configured to measure a plurality of Signal intensity, Signal quality, Interference, Dropped calls, Blocked calls, Anomalous events, Call statistics, Service level statistics, Quality of Service (QoS) information, Handover information, and Neighboring cell information. The route can include locations between handoffs with adjacent cell towers. The UAV-based process **1080** can further include, subsequent to the flying and prior to the processing, flying the UAV in a second route in a second wireless coverage area associated with a second cell tower; and collecting second measurement data via the wireless coverage testing configuration during the flying the second route and associating the collected second measurement data with second location identifiers.

In another exemplary embodiment, an Unmanned Aerial Vehicle (UAV) adapted for wireless coverage testing includes one or more rotors disposed to a body; wireless interfaces; a wireless coverage testing configuration; a processor coupled to the wireless interfaces, the one or more rotors, and the wireless coverage testing configuration; and memory storing instructions that, when executed, cause the

processor to: cause the UAV to fly in a route in a wireless coverage area associated with a cell tower; collect measurement data via the wireless coverage testing configuration during the flight and associate the collected measurement data with location identifiers; and, subsequent to the flight, provide the collected measurement data with the location identifiers for processing to provide an output detailing wireless coverage in the wireless coverage area including wireless coverage at ground level and above ground level to a set elevation.

§ 14.0 Installation of Equipment with UAVs

Referring to FIG. **34**, in an exemplary embodiment, a diagram illustrates a partial view of the exemplary cell site **10** for describing installation of equipment with the UAV **50**. Again, the cell site **10** includes the cell tower **12**. The cell tower **12** includes horizontal support structures **1100**, **1102** which are attached to a pole **1104** at varying heights. The antennas **30** are attached/supported by the horizontal support structures **1100**, **1102**. Techniques are described herein for installing the antennas **30** via the UAV **50**. Those of ordinary skill in the art will recognize that other types of equipment could also be installed using these techniques, such as lighting rods, lights, radios, and the like. For example, conventionally, radios were located in the shelter or cabinet **52**. However, which use of different spectrum, e.g., 1.9 GHz, some radios are being located closer to the antennas **30**. Additionally, some configurations support integration of the radios in the antennas **30**.

The UAV **50** is configured to provide the equipment, such as the antenna **30**, up the cell tower **12** to the appropriate location, i.e., the horizontal support structures **1100**, **1102**. Note, the horizontal support structures **1100**, **1102** can be located in the middle or the top of the cell tower **12**. The UAV **50** can include additional rotors **80** and the rotors **80** can be larger. Also, the body **82** can be larger as well. Generally, for the systems and methods described herein, the UAV **50** is configured to support equipment weighing a couple hundred pounds, such as, for example, 150-250 lbs. The UAV **50** can support the equipment through the robotic arms **600**. Also, the arms **60** can be fixed. In an exemplary embodiment, the UAV **50** does not require the arms **60** to move the equipment, but rather the entire UAV **50** moves the equipment and places it appropriately. However, the arms **600** are configured to hold the equipment during the flight and to release once positioned and connected to the horizontal support structures **1100**, **1102**.

The arms **600** are configured based on the type of equipment they support. For example, the antennas **30** are typically rectangular and the arms **600** can be configured to clasp a center portion of the antenna **30**. The UAV **50** generally flies vertically from the base of the cell tower **12** with the antenna **30** secured in the arms **600**. For example, the antenna **30** can be secured to the arms **600** on the ground at the base of the cell tower **12** by one or more installers.

Once secured, the UAV **50** can be manually, automatically, or a combination of both flown to the appropriate location on the cell tower **12**, i.e., the horizontal support structures **1100**, **1102**. Note, the systems and methods contemplate an operator flying the UAV **50** as described herein. In another embodiment, the UAV **50** can operate autonomously or semi-autonomously, such as based on directional aids, location identifiers, objects of interest, or the like. For example, the UAV **50**, via a processor **102** or the like, can be programmed with the location on the horizontal support structures **1100**, **1102** for placement. The UAV **50** can use the directional aids, location identifiers, objects of interest, or the like to direct the flight based on the location.

Referring to FIG. 35, in an exemplary embodiment, a diagram illustrates a view of the horizontal support structures 1100, 1102 and the antenna 30. The horizontal support structures 1100, 1102 can include directional aids 1150 indicative of a location where the antenna 30 or other equipment is to be placed. The directional aids 1150 can be barcodes, Quick Response (QR) codes, a number, a symbol, a picture, a color, a phrase such as “drop here,” or combinations thereof. The directional aids 1150 can be detected and monitored by the camera 86 in the UAV 50 which can maintain a visual connection to determine proper flight, such as a feedback loop to automatically fly to the horizontal support structures 1100, 1102 to place the antenna 30. Those of ordinary skill in the art will recognize the UAV 50 can use any autonomous flight algorithm with the directional aids 1150 providing the location to arrive at.

The horizontal support structures 1100, 1102 can include magnets 1152 and the antenna 30 can also include magnets 1154. In an exemplary embodiment, only one of the horizontal support structures 1100, 1102 and the antenna 30 include the magnets 1152, 1154. In another exemplary embodiment, both the horizontal support structures 1100, 1102 and the antenna 30 include the magnets 1152, 1154. Generally, the magnets 1152, 1154 can be used to hold the antenna 30 on the horizontal support structures 1100, 1102, i.e., the UAV 50 can place the antenna 30 on the horizontal support structures 1100, 1102 with the magnets 1100, 1102. The magnets 1152, 1154 can be permanent magnets or electrically energized magnets. For example, the magnets 1152, 1154 can be selectively magnetic using the electrically energized magnets.

This selective magnetic embodiment can be used to have the magnets 1152, 1154 for temporary use, i.e., the UAV 50 places the antenna 30 on the horizontal support structures 1100, 1102 with the magnets 1152, 1154 used to temporarily hold the antenna 30 in place while the antenna is physically attached to the horizontal support structures 1100, 1102. Once the antenna 30 is fixedly attached to the horizontal support structures 1100, 1102, the magnets 1152, 1154 can be turned off. Note, the magnets 1152, 1154, when energized or magnetic, may interfere with the antennas 30. Thus, the selective magnetic embodiment allows for the magnets 1152, 1154 to become non-magnetic after they are fixed to the horizontal support structures 1100, 1102.

The horizontal support structures 1100, 1102 are generally not drilled into and the attachment between the horizontal support structures 1100, 1102 and the antennas 30 can be a clamp 1156. In an exemplary embodiment, the clamp 1156 is attached to the antenna 30 after the UAV 50 delivers the antenna 30 and has it held in place by the magnets 1152, 1154 by an installer on the cell tower. Here, the installer can perform normal installation with the systems and methods providing a convenient and efficient mechanism to deliver the antenna 30.

In another exemplary embodiment, the clamps 1156 have an automatic mechanical grabbing feature where no installer is required. Here, the UAV 50 can fly the antenna 30 to the clamps 1156 and the clamps 1156 can automatically attach to the antenna 30. This automatic mechanical feature may or may not use the magnets 1152, 1154. For example, the clamps 1156 can have a mechanical locking mechanism similar to handcuffs where the UAV 50 pushes the antenna 30 in and the clamps automatically lock.

In a further exemplary embodiment, the automatic mechanical feature can include other techniques such as a vacuum on the horizontal support structures 1100, 1102 or the antenna 30 which can selectively grab and connect.

In a further exemplary embodiment, the magnets 1152, 1154 can be used to hold the antenna 30 in place and the robotic arms 600 can be used to fixedly attach the antenna 30, such as via the clamps 1156. All of the techniques described herein are also contemplate for operations during the installation.

§ 14.1 UAV-Based Installation Method

Referring to FIG. 36, in an exemplary embodiment, a flowchart illustrates an Unmanned Aerial Vehicle (UAV)-based installation method 1180 for equipment on cell towers. The UAV-based installation method 1180 includes flying the UAV with the equipment attached thereto upwards to a desired location on the cell tower, wherein the desired location includes one or more horizontal support structures (step 1182); positioning the equipment to the desired location on the cell tower (step 1184); connecting the equipment to the desired location (step 1186); and disconnecting the equipment from the UAV (step 1188). The UAV-based installation method 1180 can further include attaching the equipment to the UAV via one or more robotic arms prior to the flying. The equipment can include one or more of an antenna and a radio. The positioning can be via one or more directional aids located on the one or more horizontal support structures, wherein the directional aids are monitored via a camera associated with the UAV. The one or more directional aids can include one or more of barcodes, Quick Response (QR) codes, numbers, symbols, pictures, a color, a phrase, and a combination thereof.

The positioning can include temporarily fixing the equipment to the desired location for the connecting. The positioning can include attaching the equipment to the desired location via one or more magnets. The one or more magnets can be selectively energized for the positioning and the connecting and turned off subsequent to the connecting. The connecting can include attaching one or more clamps between the equipment and the one or more horizontal support structures. The one or more clamps can automatically connect to the equipment. The flying can be performed by an operator with assistance from one or more directional aids located on the one or more horizontal support structures. The flying can be performed by autonomously by the UAV based on one or more directional aids located on the one or more horizontal support structures. The UAV-based installation method 1180 can further include performing the disconnecting subsequent to the positioning; and using one or more robotic arms on the UAV to perform the connecting.

In another exemplary embodiment, an Unmanned Aerial Vehicle (UAV) used in installation of equipment on cell towers includes one or more rotors disposed to a body; wireless interfaces; one or more arms adapted to connect and disconnect from the equipment; a processor coupled to the wireless interfaces, the one or more rotors, and the one or more arms; and memory storing instructions that, when executed, cause the processor to: fly with the equipment attached to the one or more arms upwards to a desired location on the cell tower, wherein the desired location includes one or more horizontal support structures; position the equipment to the desired location on the cell tower; connect the equipment to the desired location; and disconnect the equipment from the UAV.

§ 15.0 Installation and Maintenance of Equipment on Cell Towers with Robotic Devices

Referring to FIGS. 37A-37C, in various exemplary embodiments, diagrams illustrate different types of cell towers 12, namely a self-support tower 12A (FIG. 37A), a monopole tower 12B (FIG. 37B), and a guyed tower 12C (FIG. 37C). These three types of towers 12A, 12B, 12C have

different support mechanisms. The self-support tower **10A** can also be referred to as a lattice tower and it is free standing, with a triangular base with three or four sides. The monopole tower **12B** is a single tube tower and it is also free standing, but typically at a lower height than the self-support tower **12A**. The guyed tower **12C** is a straight rod supported by wires attached to the ground.

Referring to FIG. **38**, in an exemplary embodiment, a block diagram illustrates a robotic device **1200** configured for use with the cell towers **12A**, **12B**, **12C** for installation and/or maintenance of cell site components **14** on the cell towers **12A**, **12B**, **12C**. The robotic device **1200** is configured to traverse up and down the cell tower **12** with climbing components **1202** and to perform physical manipulation of equipment, cabling, etc. with manipulation components **1204**. In addition to the climbing components **1202** and the manipulation components **1204**, the robotic device **1200** includes a body **1206** which may include power, physical support for the climbing components **1202** and the manipulation components **1204**, processing (e.g., the robotic device **1200** can include the mobile device **100** or equivalent disposed or associated with the body **1206**).

Thus, the robotic device **1200** reduces or avoids tower climbs for installation and maintenance on equipment on the cell towers **12**. The robotic device **1200** can crawl to the top of the cell tower **12**, can be delivered by Unmanned Aerial Vehicles (UAV) **50**, can be delivered by guide wire, can be delivered by a crane, pulley, etc. or the like. While on the cell tower **12**, the robotic devices **1200** can be used, either manually, autonomously, or a combination of both, to perform various tasks on cell tower components **14** such as antennas or the like. In an exemplary embodiment, the robotic device **1200** can be used to bring cabling up the cell tower **12** in conjunction with UAV-based systems and methods which install equipment such as antennas.

The climbing components **1202** are configured to allow the robotic device **1200** to traverse up and down the cell tower **12**. Those of ordinary skill in the art will recognize the robotic device **1200** can include any mechanism for climbing, but in an exemplary embodiment, the climbing components **1202** can include various wheels **1210**. For example, to traverse the self-support tower **12A**, the monopole tower **12B**, the guyed tower **12C**, etc., wheels **1210A**, **1210B** are on the body **1206** to roll up or down the tower **12** while a wheel **1210C** is spaced apart from the body **1206** via a member **1212** to keep the robotic device **1200** affixed to the tower **12** during transit. Also, this arrangement of the climbing components **1202** could be used with a guide wire to traverse up and down the cell tower **12**.

The manipulation components **1204** can include one or more robotic arms **1220** which can include a member **1222** which is rotatable or moveable relative to the body **1206** and a grasping device **1224** which can physically interact and/or manipulate with the cell site components **14**. The robotic device **1200** can include multiple arms **1220** in some embodiments and a single arm **1220** in another embodiment.

In another exemplary embodiment, the climbing components **1202** can be the same as the manipulation components **120**, such as when there is more than one robotic arm **1220**. Here, the robotic arms **1220** can be used to both install/manipulate the cell site components **14** as well as to climb the cell tower **12**. For example, the robotic arms **1220** can grasp stairs on the cell tower **12**, supports on a lattice tower, safety climb wires, or the like.

The climbing components **1202** may also include magnets including selectively enabled magnets. Note, the cell towers

12 include metal and the magnets could be used to traverse up and down the cell tower **12**.

Thus, in operation, the climbing components **1202** are used to traverse up and down the cell tower as well as to maintain the robotic device **1200** in a stable position at a desired location on the cell tower **12**. Once at the desired location, the manipulation components **1204** are used to perform installation and/or maintenance. For example, the manipulation components **1204** can be controlled with a mobile device **100** or controller which is wirelessly connected to the robotic device **1200**, through a Heads Up Display (HUD) or Virtual Reality (VR) controller which is wirelessly connected to the robotic device **1200**, or the like. With the HUD or VR controller, an operator can remotely operate the robotic device **1200**, from the ground, thereby having arms in the sky without the tower climb.

The manipulation components **1204** can be used to perform similar functionality as the robotic arms **600**, including bringing the payload **602** up the cell tower **12**. In an exemplary embodiment, the manipulation components **1204** can be used to bring cabling up the cell tower **12**, such as in conjunction with the UAV-based installation method **1180**.

In an exemplary embodiment, a plurality of robotic devices **1200** can be used in combination. For example, the plurality of mobile devices **1200** can combine with one another at a desired location to form an aggregate robotic device.

Referring to FIG. **39**, in an exemplary embodiment, a flowchart illustrates a method **1300** for installation and maintenance of cell site components with the robotic device **1200**. The method **1300** includes causing the robotic device to traverse up the cell tower to a desired location proximate to the cell site components (step **1302**); once at the desired location and stabilized to the cell tower, causing manipulation components to perform one or more of installation and maintenance of the cell site components (step **1304**); and, subsequent to the one or more of installation and maintenance of the cell site components, causing the robotic device to traverse down the cell tower (step **1306**).

The robotic device traverses up and down the cell tower via climbing components associated with the robotic device. The climbing components can include a plurality of wheels configured to traverse the cell tower and stabilize the robotic device to the cell tower; a plurality of magnets; and a pulley system. The cell tower can include one of a self-support tower, a monopole tower, and a guyed tower, and climbing components for the robotic device are configured based on a type of the cell tower.

The manipulation components can include one or more members with robotic arms coupled thereto. The robotic device can include a body comprising a processor and wireless components; climbing components disposed to the body; and the manipulation components moveably disposed to the body.

The causing can be performed by one of a mobile device and a controller wirelessly coupled to the robotic device. The causing can be performed by one of a Heads Up Display and a Virtual Reality controller wirelessly coupled to the robotic device. The robotic device can be utilized to bring a cable up the cell tower and to connect the cable to the cell site components. The cell site components can be installed by an Unmanned Aerial Vehicle (UAV).

In another exemplary embodiment, an apparatus for installation and maintenance of cell site components on a cell tower with a robotic device includes a wireless interface; a processor communicatively coupled to the wireless interface; and memory storing instructions that, when

executed, cause the processor to cause the robotic device to traverse up the cell tower to a desired location proximate to the cell site components; once at the desired location and stabilized to the cell tower, cause manipulation components to perform one or more of installation and maintenance of the cell site components; and, subsequent to the one or more of installation and maintenance of the cell site components, cause the robotic device to traverse down the cell tower.

§ 16.0 Close-Out Audit Systems and Methods

Again, a close-out audit is done to document and verify the work performed at the cell site **10**. The systems and methods eliminate the separate third-party inspection firm for the close-out audit. The systems and methods include the installers (i.e., from the third-party installation firm, the owner, the operator, etc.) performing video capture subsequent to the installation and maintenance and using various techniques to obtain data from the video capture for the close-out audit. The close-out audit can be performed off-site with the data from the video capture thereby eliminating unnecessary tower climbs, site visits, and the like.

Referring to FIG. **40**, in an exemplary embodiment, a flowchart illustrates a close-out audit method **1350** performed at a cell site subsequent to maintenance or installation work. The close-out audit method **1350** includes, subsequent to the maintenance or installation work, obtaining video capture of cell site components associated with the work (step **1352**); subsequent to the video capture, processing the video capture to obtain data for the close-out audit, wherein the processing comprises identifying the cell site components associated with the work (step **1354**); and creating a close-out audit package based on the processed video capture, wherein the close-out audit package provides verification of the maintenance or installation work and outlines that the maintenance or installation work was performed in a manner consistent with an operator or owner's guidelines (step **1356**).

The video capture can be performed by a mobile device and one or more of locally stored thereon and transmitted from the mobile device. The video capture can also be performed by a mobile device which wirelessly transmits a live video feed and the video capture is remotely stored from the cell site. The video capture can also be performed by an Unmanned Aerial Vehicle (UAV) flown at the cell site. Further, the video capture can be a live video feed with two-way communication between an installer associated with the maintenance or installation work and personnel associated with the operator or owner to verify the maintenance or installation work. For example, the installer and the personnel can communicate to go through various items in the maintenance or installation work to check/audit the work.

The close-out audit method **1350** can also include creating a three-dimensional (3D) model from the video capture; determining equipment location from the 3D model; measuring distances between the equipment and within the equipment to determine actual spatial location; and determining connectivity between the equipment based on associated cabling from the 3D model. The close-out audit method **1350** can also include uniquely identifying the cell site components from the video capture and distinguishing in the close-out audit package. The close-out audit method **1350** can also include determining antenna height, azimuth, and down tilt angles for antennas in the cell site components from the video capture; and checking the antenna height, azimuth, and down tilt angles against predetermined specifications.

The close-out audit method **1350** can also include identifying cabling and connectivity between the cell site components from the video capture and distinguishing in the close-out audit package. The close-out audit method **1350** can also include checking a plurality of factors in the close-out audit from the video capture compared to the operator or owner's guidelines. The close-out audit method **1350** can also include checking grounding of the cell site components from the video capture, comparing the checked grounding to the operator or owner's guidelines and distinguishing in the close-out audit package. The close-out audit method **1350** can also include checking mechanical connectivity of the cell site components to a cell tower based on the video capture and distinguishing in the close-out audit package.

In another exemplary embodiment, a system adapted for a close-out audit of a cell site subsequent to maintenance or installation work includes a network interface and a processor communicatively coupled to one another; and memory storing instructions that, when executed, cause the processor to, subsequent to the maintenance or installation work, obtain video capture of cell site components associated with the work; subsequent to the video capture, process the video capture to obtain data for the close-out audit, wherein the processing comprises identifying the cell site components associated with the work; and create a close-out audit package based on the processed video capture, wherein the close-out audit package provides verification of the maintenance or installation work and outlines that the maintenance or installation work was performed in a manner consistent with an operator or owner's guidelines.

In a further exemplary embodiment, a non-transitory computer readable medium includes instructions that, when executed, cause one or more processors to perform the steps of, subsequent to the maintenance or installation work, obtaining video capture of cell site components associated with the work; subsequent to the video capture, processing the video capture to obtain data for the close-out audit, wherein the processing comprises identifying the cell site components associated with the work; and creating a close-out audit package based on the processed video capture, wherein the close-out audit package provides verification of the maintenance or installation work and outlines that the maintenance or installation work was performed in a manner consistent with an operator or owner's guidelines.

The close-out audit package can include, without limitation, drawings, cell site component settings, test results, equipment lists, pictures, commissioning data, GPS data, Antenna height, azimuth and down tilt data, equipment data, serial numbers, cabling, etc.

§ 17.0 3D Modeling Systems and Methods

Referring to FIG. **41**, in an exemplary embodiment, a flowchart illustrates a 3D modeling method **1400** to detect configuration and site changes. The 3D modeling method **1400** utilizes various techniques to obtain data, to create 3D models, and to detect changes in configurations and surroundings. The 3D models can be created at two or more different points in time, and with the different 3D models, a comparison can be made to detect the changes. Advantageously, the 3D modeling systems and methods allow cell site operators to efficiently manage the cell sites without repeated physical site surveys.

The modeling method **1400** includes obtaining first data regarding the cell site from a first audit performed using one or more data acquisition techniques and obtaining second data regarding the cell site from a second audit performed using the one or more data acquisition techniques, wherein

the second audit is performed at a different time than the first audit, and wherein the first data and the second data each comprise one or more location identifiers associated therewith (step **1402**); processing the first data to define a first model of the cell site using the associated one or more location identifiers and processing the second data to define a second model of the cell site using the associated one or more location identifiers (step **1404**); comparing the first model with the second model to identify the changes in or at the cell site (step **1406**); and performing one or more actions based on the identified changes (step **1408**).

The one or more actions can include any remedial or corrective actions including maintenance, landscaping, mechanical repair, licensing from operators who install more cell site components **14** than agreed upon, and the like. The identified changes can be associated with cell site components installed on a cell tower at the cell site, and wherein the one or more actions comprises any of maintenance, licensing with operators, and removal. The identified changes can be associated with physical surroundings of the cell site, and wherein the one or more actions comprise maintenance to correct the identified changes. The identified changes can include any of degradation of gravel roads, trees obstructing a cell tower, physical hazards at the cell site, and mechanical issues with the cell tower or a shelter at the cell site.

The first data and the second data can be obtained remotely, without a tower climb. The first model and the second model each can include a three-dimensional model of the cell site, displayed in a Graphical User Interface (GUI). The one or more data acquisition techniques can include using an Unmanned Aerial Vehicle (UAV) to capture the first data and the second data. The one or more data acquisition techniques can include using a fixed or portable camera to capture the first data and the second data. The one or more location identifiers can include at least two location identifiers comprising Global Positioning Satellite (GPS) and GLObal NAvigation Satellite System (GLONASS). The second model can be created using the first model as a template for expect objects at the cell site.

In another exemplary embodiment, a modeling system adapted for detecting changes in or at a cell site includes a network interface and a processor communicatively coupled to one another; and memory storing instructions that, when executed, cause the processor to obtain first data regarding the cell site from a first audit performed using one or more data acquisition techniques and obtain second data regarding the cell site from a second audit performed using the one or more data acquisition techniques, wherein the second audit is performed at a different time than the first audit, and wherein the first data and the second data each comprise one or more location identifiers associated therewith; process the first data to define a first model of the cell site using the associated one or more location identifiers and process the second data to define a second model of the cell site using the associated one or more location identifiers; compare the first model with the second model to identify the changes in or at the cell site; and cause performance of one or more actions based on the identified changes.

In a further exemplary embodiment, a non-transitory computer readable medium includes instructions that, when executed, cause one or more processors to perform the steps of: obtaining first data regarding the cell site from a first audit performed using one or more data acquisition techniques and obtaining second data regarding the cell site from a second audit performed using the one or more data acquisition techniques, wherein the second audit is per-

formed at a different time than the first audit, and wherein the first data and the second data each comprise one or more location identifiers associated therewith; processing the first data to define a first model of the cell site using the associated one or more location identifiers and processing the second data to define a second model of the cell site using the associated one or more location identifiers; comparing the first model with the second model to identify the changes in or at the cell site; and performing one or more actions based on the identified changes.

§ 18.0 Using Drones to Transport Maintenance Personnel to a Cell Tower

Referring to FIGS. **42-44**, in various exemplary embodiments, diagrams illustrate drones **1450**, **1452** and a single person propulsion system **1454** each adapted to transport a person up the cell tower **12**. Specifically, FIG. **42** is a diagram of a drone adapted to transport a person up a cell tower; FIG. **43** is a diagram of another drone adapted to transport a person up the cell tower; and FIG. **44** is a diagram of a single person propulsion system adapted to transport a person up the cell tower. Those of ordinary skill in the art that any type of drone or propulsion system is contemplated herein.

The drones **1450**, **1452** or the system **1454** are adapted to quickly and safely bring maintenance personnel up to the cell tower **12** in lieu of a tower climb. After performing numerous tower climbs for cell site audits, maintenance, installation, etc., a time study was performed which showed the process of a tower climb takes well over an hour, including suiting up with gear, climbing the cell tower **12**, clicking in and out of safety harnesses along the way, etc. Also, maintenance personnel are exhausted at the end of the tower climb.

The drone **1450** includes a support structure **1460** with a plurality of rotors thereon. A person (or multiple persons) are connected to the support structure **1460** via support wires or members **1462**. The person can sit in a seat **1464** or connect to the members **1462** via harnesses, a vest, etc. (not shown). The seat **1464** can include landing members **1466**. If the support wires or members **1462** are rigid members, the landing members **1466** can support the drone **1450** on the ground. If the support wires or members **1462** are wires, the support structure **1460** can land apart from the person, take off and lift the person.

The drone **1452** includes a single set of rotors **1470** connected to a motor **1472** which connects to a support member **1474** which extends for a distance and connects to a base **1476**. The base **1476** can support maintenance personnel through harnesses, a vest, or a seat. The base **1476** can connect to landing members **1478** which support the drone **1452** on the ground. A control system **1480** extends from the support member **1474** for control of the drone **1452**.

Both of the drones **1450**, **1452** are specifically adapted to the task of raising and lowering people along the cell tower **12**. Specifically, the support wires or members **1462** and the support member **1474** have significant length allowing the support structure **1460** or the rotors **1470** to clear the top of the cell tower **12**. In this manner, the drones **1450**, **1452** can position a person directly adjacent to the cell tower **12** such as to a platform thereon without interfering, i.e., touching, causing damage, etc., to the cell tower **12** or the cell site components **14**.

In FIG. **44**, the single person propulsion system **1454** is shown which includes a base **1490** which connects to one or more jet propulsion systems **1492** and a harness **1494**. Here,

a person connects to the harness **1494** and uses the jet propulsion systems **1492** to go up the cell tower **12**.

Again, the present disclosure contemplates any other means of aerial propulsion such as helicopters, quadcopters, or the like. In an exemplary embodiment, a key aspect is any system should include enough length, i.e., a substantial length, between the aerial flying components and any maintenance personnel such that the aerial flying components can extend over the height of the cell tower **12** such that the cell tower **12** and the cell site components **14** are protected and such that the maintenance personnel can be placed directly adjacent to a desired location on the cell tower **12**. The substantial length can be 20-40 feet or the like. Note, the drones **1450**, **1452** only require substantially vertical flight to go up and down. Thus, having the flying components significantly higher than the person is not an issue.

Referring to FIG. **45**, in an exemplary embodiment, a diagram illustrates a cell tower with various platforms **1500** for receiving a person from a drone or the like. Using drones, it is necessary to have a place to locate maintenance personnel on the cell tower **12**. In an exemplary embodiment, the cell tower **12** can include fixed or removable platforms **1500** for the drones **1450**, **1452** or the like to place the personnel and for the personnel to get back in the drones **1450**, **1452** to fly back to the ground. The drones **1450**, **1452** can include a connection to safely connect to the platforms **1500** for stability during ingress and egress.

In an exemplary embodiment, the platforms **1500** are fixed, i.e., built into the cell tower **12**. In another exemplary embodiment, the platforms **1500** are selectively removable and can be added by the maintenance personnel on an as needed basis. For example, the platform **1500** can also be connected to the drones **1450**, **1452** and be locked into place on the cell tower **12** during maintenance. After maintenance and after the personnel are back in the drones **1450**, **1452**, the platforms **1500** can be removed and brought back to the ground with the personnel.

The present disclosure can be used for site audits, site surveys, maintenance, and installation to avoid slow, inefficient tower climbs. In an exemplary embodiment, at least two drones **1450**, **1452** can be on site—one for operation and one for backup.

The drones **1450**, **1452** can operate autonomously based on location identification information since the flight plan here is constrained to a small area, i.e., just at the cell tower **12**. For example, using a GUI or the like, an exact position can be specified such as on a map, 3D model, photograph or the like, and the drones **1450**, **1452** can automatically fly to this location, avoiding the cell tower **12** or cell site components **14**. In another exemplary embodiment, the drones **1450**, **1452** can fly under control of the person therein or via remote control from an operator.

In an exemplary embodiment, the drones **1450**, **1452** are configured to bring the person to the top of the cell tower **12**, and if there is a need to access lower cell site components **14**, the person can perform a tower climb down, using safety harnesses, etc. Climbing down slightly is quick and does not exhaust the same amount of physical resources.

Referring to FIG. **46**, in an exemplary embodiment, a flowchart illustrates a method **1550** for transporting maintenance personnel to a cell tower **12**. The method **1550** includes, responsive to a requirement for a tower climb for one or more of a site survey, a site audit, maintenance, and installation at the cell tower, securing a person in a drone, wherein the drone comprises flight components at a substantial length from the person allowing the flight components to fly over a top of the cell tower and to place the

person directly adjacent to a desired location on the cell tower (step **1552**); flying the drone up the cell tower to locate the person directly adjacent to the desired location (step **1554**); and performing the one or more of a site survey, a site audit, maintenance, and installation at the cell tower (step **1556**).

The method **1550** can further include connecting to a platform on the cell tower for the person to egress and ingress to the drone. The platform can be transported with the drone and selectively connected to the cell tower by the person. The drone can include a support structure with a plurality of rotors and support wires or members for the securing, wherein the support wires or members comprise the substantial length. The drone can include a single set of rotors connected to a motor connected to a base via a support member, wherein the person is secured to the base, and wherein the support member comprises the substantial length. The drone can include a single person propulsion system. The drone can be automatically guided to the desired location based on location identifiers and wherein the desired location is set via a Graphical User Interface or three-dimensional model of the cell tower. The drone can be one of manually operated by the person and by remote control via an operator. The method **1550** can further include maintaining a second drone for backup. The substantial length can be at least 20 feet.

In another exemplary embodiment, a drone for transporting maintenance personnel at a cell tower includes one or more rotors connected to a structure; one or more support members connected to the structure, wherein a person is selectively secured to the one or more support members, wherein the one or more support members comprise a substantial length from the person to the one or more rotors allowing the one or more rotors to fly over a top of the cell tower and to place the person directly adjacent to a desired location on the cell tower; wherein, responsive to a requirement for a tower climb for one or more of a site survey, a site audit, maintenance, and installation at the cell tower, the drone is adapted to fly the person up the cell tower for performance thereof. The drone can further include a connector adapted to connect to a platform on the cell tower for the person to egress and ingress to the drone. The platform can be transported with the drone and selectively connected to the cell tower by the person.

The drone can include a plurality of rotors and the one or more support members comprise support wires or members connected to the structure for the securing, wherein the support wires or members comprise the substantial length. The one or more rotors can include a single set of rotors connected to a motor on the structure and the one or more support members comprise a single support member, wherein the person is secured to a base connected to the single support member, and wherein the single support member comprises the substantial length. The drone can include a single person propulsion system. The drone can be automatically guided to the desired location based on location identifiers and wherein the desired location is set via a Graphical User Interface or three-dimensional model of the cell tower. The drone can be one of manually operated by the person and by remote control via an operator. A second drone can be maintained at the cell tower for backup. The substantial length can be at least 20 feet.

§ 19.0 UAV Counterbalancing Techniques

Referring to FIGS. **47A**, **47B**, and **47C**, in exemplary embodiments, diagrams illustrate various counterbalance techniques for the UAV **50** including an extendible arm **1600** (FIG. **47A**), opposing robotic arms **600A** (FIG. **47B**), and

moveable weights **1650** (FIG. 47C). As described herein, the UAV **50** can be used with the robotic arms **600**, the payload **602**, the connection **604**, etc. The UAV **50** can be used to attach the antenna **30** to the horizontal support structures **1100**, **1102**, and the like. In these applications and others, the UAV **50** has weight distribution change while in flight. Accordingly, the UAV counterbalancing techniques are presented to compensate for weight distribution change in flight to avoid negative impact on the UAV **50** flight.

Variouly, the counterbalancing techniques ensure weight distribution on the UAV **50** remains substantially the same despite moving members on the UAV **50**, e.g., robotic arms **600**, the connection **604**, etc. In FIG. 47A, a first counterbalancing technique includes the extendible arm **1600** which can extend coincident with movement of the robotic arms **600** to offset any weight distribution changes. The extension can be in substantially an opposite direction as the robotic arms **600** and controlled by the processor **102** in the UAV **50** to ensure the weight distribution remains substantially the same. The extendible arms **1600** can move back and forth while the robotic arms **600** move as well to continually balance the weight distribution. The processor **102** can implement a process to balance the UAV **50** based on feedback from sensors associated with the UAV **50**, such as an accelerometer or the like. The extendible arms **1600** can also extend in the embodiment where the connection **604** extends from the UAV **50** to connect to the cell tower **12**, again to offset the weight distribution changes.

In FIG. 47B, a second counterbalancing technique includes a second set of robotic arms **600A** located on an opposite side of the UAV **50** from the robotic arms **600**. Here, any movement by the robotic arms **600** can be mirrored by the second set of robotic arms **600A** in the opposite direction. The robotic arms **600**, **600A** can be substantially the same including about the same weight. Thus, opposing movement offsets any weight distribution changes. The benefit of this approach is it requires a less sophisticated tracking process, i.e., the movements are just opposed versus taking sensor measurements and making changes accordingly. Also, either set of robotic arms **600**, **600A** could be used for operations thereby making the UAV **50** flight more convenient.

In FIG. 47C, a third counterbalancing technique includes the moveable weights **1650** which can be disposed or attached to the UAV **50**, such as on a lower portion. The moveable weights **1650** include one or more weight plates **1650**, ball bearings, etc. which have different weights and weight distribution. The direction or orientation of the plates **1650**, ball bearings, etc. can be changed via a rotating member **1654**. In this manner, the moveable weights **1650** can provide various different weight profiles to counterbalance any movement of items on the UAV **50**, such as the robotic arms **600**, the payload **602**, etc. The moveable weights **1650** can be controlled in a similar manner as the extendible arm **1600**.

§ 20.0 3D Modeling Data Capture Systems and Methods

Again, various exemplary embodiments herein describe applications and uses of 3D models of the cell site **10** and the cell tower **12**. Further, it has been described using the UAV **50** to obtain data capture for creating the 3D model. The data capture systems and methods described herein provide various techniques and criteria for properly capturing images or video using the UAV **50**. Referring to FIG. 48, in an exemplary embodiment, a flow diagram illustrates a 3D model creation process **1700**. The 3D model creation process **1700** is implemented on a server or the like. The 3D model creation process **1700** includes receiving input data,

i.e., pictures and/or video. The data capture systems and methods describe various techniques for obtaining the pictures and/or video using the UAV **50** at the cell site **10**. In an exemplary embodiment, the pictures can be at least 10 megapixels and the video can be at least 4 k high definition video.

The 3D model creation process **1700** performs initial processing on the input data (step **1702**). An output of the initial processing includes a sparse point cloud, a quality report, and an output file can be camera outputs. The sparse point cloud is processed into a point cloud and mesh (step **1704**) providing a densified point cloud and 3D outputs. The 3D model is an output of the step **1704**. Other models can be developed by further processing the densified point cloud (step **1706**) to provide a Digital Surface Model (DSM), an orthomosaic, tiles, contour lines, etc.

The data capture systems and methods include capturing thousands of images or video which can be used to provide images. Referring to FIG. 49, in an exemplary embodiment, a flowchart illustrates a method **1750** using an Unmanned Aerial Vehicle (UAV) to obtain data capture at a cell site for developing a three dimensional (3D) thereof. The method **1750** includes causing the UAV to fly a given flight path about a cell tower at the cell site (step **1752**); obtaining data capture during the flight path about the cell tower, wherein the data capture comprises a plurality of photos or video, wherein the flight path is subjected to a plurality of constraints for the obtaining, and wherein the data capture comprises one or more location identifiers (step **1754**); and, subsequent to the obtaining, processing the data capture to define a three dimensional (3D) model of the cell site based on one or more objects of interest in the data capture (step **1756**).

The method **1750** can further include remotely performing a site survey of the cell site utilizing a Graphical User Interface (GUI) of the 3D model to collect and obtain information about the cell site, the cell tower, one or more buildings, and interiors thereof (step **1758**). A launch location and launch orientation can be defined for the UAV to take off and land at the cell site such that each flight at the cell site has the same launch location and launch orientation. The one or more location identifiers can include at least two location identifiers including Global Positioning Satellite (GPS) and GLObal NAVigation Satellite System (GLO-NASS).

The plurality of constraints can include each flight of the UAV having a similar lighting condition and at about a same time of day. Specifically, the data capture can be performed on different days or times to update the 3D model. Importantly, the method **1750** can require the data capture in the same lighting conditions, e.g., sunny, cloudy, etc., and at about the same time of day to account for shadows.

The data capture can include a plurality of photographs each with at least 10 megapixels and wherein the plurality of constraints can include each photograph having at least 75% overlap with another photograph. Specifically, the significant overlap allows for ease in processing to create the 3D model. The data capture can include a video with at least 4 k high definition and wherein the plurality of constraints can include capturing a screen from the video as a photograph having at least 75% overlap with another photograph captured from the video.

The plurality of constraints can include a plurality of flight paths around the cell tower with each of the plurality of flight paths at one or more of different elevations, different camera angles, and different focal lengths for a camera. The plurality of flight paths can be one of: a first flight path at a

first height and a camera angle and a second flight path at a second height and the camera angle; and a first flight path at the first height and a first camera angle and a second flight path at the first height and a second camera angle. The plurality of flight paths can be substantially circular around the cell tower.

In another exemplary embodiment, an apparatus adapted to obtain data capture at a cell site for developing a three dimensional (3D) thereof includes a network interface and a processor communicatively coupled to one another; and memory storing instructions that, when executed, cause the processor to cause the UAV to fly a given flight path about a cell tower at the cell site; cause data capture during the flight path about the cell tower, wherein the data capture comprises a plurality of photos or video, wherein the flight path is subjected to a plurality of constraints for the data capture, and wherein the data capture comprises one or more location identifiers; and, subsequent to the data capture, process the data capture to define a three dimensional (3D) model of the cell site based on one or more objects of interest in the data capture.

§ 20.1 3D Methodology for Cell Sites

Referring to FIG. 50, in an exemplary embodiment, a flowchart illustrates a 3D modeling method 1800 for capturing data at the cell site 10, the cell tower 12, etc. using the UAV 50. The method 1800, in addition to or in combination with the method 1750, provides various techniques for accurately capturing data for building a point cloud generated 3D model of the cell site 10. First, the data acquisition, i.e., the performance of the method 1800, should be performed in the early morning or afternoon such that nothing is overexposed and there is minimum reflection off of the cell tower 12. It is also important to have a low Kp Index level to minimize the disruption of geomagnetic activity on the UAV's GPS unit, sub level six is adequate for 3D modeling as described in this claim. Of course, it is also important to ensure the camera lenses on the UAV 50 are clean prior to launch. This can be done by cleaning the lenses with alcohol and a wipe. Thus, the method 1800 includes preparing the UAV 50 for flight and programming an autonomous flight path about the cell tower 12 (step 1802).

The UAV 50 flight about the cell tower 12 at the cell site 10 can be autonomous, i.e., automatic without manual control of the actual flight plan in real-time. The advantage here with autonomous flight is the flight of the UAV 50 is circular as opposed to a manual flight which can be more elliptical, oblong, or have gaps in data collection, etc. In an exemplary embodiment, the autonomous flight of the UAV 50 can capture data equidistance around the planned circular flight path by using a Point of Interest (POI) flight mode. The POI flight mode is selected (either before or after takeoff) and once the UAV 50 is in flight, an operator can select a point of interest from a view of the UAV 50, such as but not limited to via the mobile device 100 which is in communication with the UAV 50. The view is provided by the camera 86 and the UAV 50 in conjunction with the device identified to be in communication with the UAV 50 can determine a flight plan about the point of interest. In the method 1800, the point of interest can be the cell tower 12. The point of interest can be selected at an appropriate altitude and once selected, the UAV 50 circles in flight about the point of interest. Further, the radius, altitude, direction, and speed can be set for the point of interest flight as well as a number of repetitions of the circle. Advantageously, the point of interest flight path in a circle provides an even distance about the cell tower 12 for obtaining photos and video thereof for

the 3D model. In an exemplary embodiment of a tape drop model, the UAV 50 will perform four orbits about a monopole cell tower 12 and about five or six orbits about a self-support/guyed cell tower 12. In the exemplary embodiment of a structural analysis model, the number of orbits will be increased from 2 to 3 times to acquire the data needed to construct a more realistic graphic user interface model.

Additionally, the preparation can also include focusing the camera 86 in its view of the cell tower 12 to set the proper exposure. Specifically, if the camera 86's view is too bright or too dark, the 3D modeling software will have issues in matching pictures or frames together to build the 3D model.

Once the preparation is complete and the flight path is set (step 1802), the UAV 50 flies in a plurality of orbits about the cell tower 12 (step 1804). The UAV obtains photos and/or video of the cell tower 12 and the cell site components 14 during each of the plurality of orbits (step 1806). Note, each of the plurality of orbits has different characteristics for obtaining the photos and/or video. Finally, photos and/or video is used to define a 3D model of the cell site 10 (step 1808).

For the plurality of orbits, a first orbit is around the entire cell site 10 to cover the entire cell tower 12 and associated surroundings. For monopole cell towers 12, the radius of the first orbit will typically range from 100 to 150 ft. For self-support cell towers 12, the radius can be up to 200 ft. The UAV 50's altitude should be slightly higher than that of the cell tower for the first orbit. The camera 86 should be tilted slightly down capturing more ground in the background than sky to provide more texture helping the software match the photos. The first orbit should be at a speed of about 4 ft/second (this provides a good speed for battery efficiency and photo spacing). A photo should be taken around every two seconds or at 80 percent overlap decreasing the amount that edges and textures move from each photo. This allows the software to relate those edge/texture points to each photo called tie points.

A second orbit of the plurality of orbits should be closer to the radiation centers of the cell tower 12, typically 30 to 50 ft with an altitude still slightly above the cell tower 12 with the camera 86 pointing downward. The operator should make sure all the cell site components 12 and antennas are in the frame including those on the opposite side of the cell tower 12. This second orbit will allow the 3D model to create better detail on the structure and equipment in between the antennas and the cell site components 14. This will allow contractors to make measurements on equipment between those antennas. The orbit should be done at a speed around 2.6 ft/second and still take photos close to every 2 seconds or keeping an 80 percent overlap.

A third orbit of the plurality of orbits has a lower altitude to around the mean distance between all of the cell site components 14 (e.g., Radio Access Devices (RADs)). With the lower altitude, the camera 86 is raised up such as 5 degrees or more because the ground will have moved up in the frame. This new angle and altitude will allow a full profile of all the antennas and the cell site components 14 to be captures. The orbit will still have a radius around 30 to 50 ft with a speed of about 2.6 ft/second.

The next orbit should be for a self-support cell tower 12. Here, the orbit is expanded to around 50 to 60 ft and the altitude decreased slightly below the cell site components 14 and the camera 86 angled slightly down more capturing all of the cross barring of the self-support structure. All of the structure to the ground does not need to be captured for this orbit but close to it. The portion close to the ground will be

captured in the next orbit. However, there needs to be clear spacing in whatever camera angle chosen. The cross members in the foreground should be spaced enough for the cross members on the other side of the cell tower **12** to be visible. This is done for self-support towers **12** because of the complexity of the structure and the need for better detail which is not needed for monopoles in this area. The first orbit for monopoles provides more detail because they are at a closer distance with the cell towers **12** lower height. The speed of the orbit can be increased to around 3 ft/second with the same spacing.

The last orbit for all cell towers **12** should have an increased radius to around 60 to 80 ft with the camera **86** looking more downward at the cell site **10**. The altitude should be decreased to get closer to the cell site **10** compound. The altitude should be around 60 to 80 ft but will change slightly depending on the size of the cell site **10** compound. The angle of the camera **86** with the altitude should be such to where the sides and tops of structures such as the shelters will be visible throughout the orbit. It is important to make sure the whole cell site **10** compound is in frame for the entire orbit allowing the capture of every side of everything inside the compound including the fencing. The speed of the orbit should be around 3.5 ft/second with same photo time spacing and overlap.

The total amount of photos that should be taken for a monopole cell tower **12** should be around 300-400 and the total amount of photos for self-support cell tower **12** should be between 400-500 photos. Too many photos can indicate that the photos were taking to close together. Photos taken in succession with more than 80 percent overlap can cause errors in the processing of the model and cause extra noise around the details of the tower and lowering the distinguishable parts for the software.

§ 21.0 3D Modeling Data Capture Systems and Methods Using Multiple Cameras

Referring to FIGS. **51A** and **51B**, in an exemplary embodiment, block diagrams illustrate a UAV **50** with multiple cameras **86A**, **86B**, **86C** (FIG. **51A**) and a camera array **1900** (FIG. **51B**). The UAV **50** can include the multiple cameras **86A**, **86B**, **86C** which can be located physically apart on the UAV **50**. In another exemplary embodiment, the multiple cameras **86A**, **86B**, **86C** can be in a single housing. In all embodiments, each of the multiple cameras **86A**, **86B**, **86C** can be configured to take a picture of a different location, different area, different focus, etc. That is, the cameras **86A**, **86B**, **86C** can be angled differently, have different focus, etc. The objective is for the cameras **86A**, **86B**, **86C** together to cover a larger area than a single camera **86**. In a conventional approach for 3D modeling, the camera **86** is configured to take hundreds of pictures for the 3D model. For example, as described with respect to the 3D modeling method **1800**, 300-500 pictures are required for an accurate 3D model. In practice, using the limitations described in the 3D modeling method **1800**, this process, such as with the UAV **50**, can take hours. It is the objective of the systems and methods with multiple cameras to streamline this process such as reduce this time in half or more. The cameras **86A**, **86B**, **86C** are coordinated and communicatively coupled to one another and the processor **102**.

In FIG. **51B**, the camera array **1900** includes a plurality of cameras **1902**. Each of the cameras **1902** can be individual cameras each with its own settings, i.e., angle, zoom, focus, etc. The camera array **1900** can be mounted on the UAV **50**, such as the camera **86**. The camera array **1900** can also be portable, mounted on or at the cell site **10**, and the like.

In the systems and methods herein, the cameras **86A**, **86B**, **86C** and the camera array **1900** are configured to work cooperatively to obtain pictures to create a 3D model. In an exemplary embodiment, the 3D model is of a cell site **10**. As described herein, the systems and methods utilize at least two cameras, e.g., the cameras **86A**, **86B**, or two cameras **1902** in the camera array **1900**. Of course, there can be greater than two cameras. The multiple cameras are coordinated such that one event where pictures are taken produce at least two pictures. Thus, to capture 300-500 pictures, less than 150-250 pictures are actually taken.

Referring to FIG. **52**, in an exemplary embodiment, a flowchart illustrates a method **1950** using multiple cameras to obtain accurate three-dimensional (3D) modeling data. In the method **1950**, the multiple cameras are used with the UAV **50**, but other embodiments are also contemplated. The method **1950** includes causing the UAV to fly a given flight path about a cell tower at the cell site (step **1952**); obtaining data capture during the flight path about the cell tower, wherein the data capture includes a plurality of photos or video subject to a plurality of constraints, wherein the plurality of photos are obtained by a plurality of cameras which are coordinated with one another (step **1954**); and, subsequent to the obtaining, processing the data capture to define a three dimensional (3D) model of the cell site based on one or more objects of interest in the data capture (step **1956**). The method **1950** can further include remotely performing a site survey of the cell site utilizing a Graphical User Interface (GUI) of the 3D model to collect and obtain information about the cell site, the cell tower, one or more buildings, and interiors thereof (step **1958**). The flight path can include a plurality of orbits comprising at least four orbits around the cell tower each with a different set of characteristics of altitude, radius, and camera angle.

A launch location and launch orientation can be defined for the UAV to take off and land at the cell site such that each flight at the cell site has the same launch location and launch orientation. The plurality of constraints can include each flight of the UAV having a similar lighting condition and at about a same time of day. A total number of photos can include around 300-400 for the monopole cell tower and 500-600 for the self-support cell tower, and the total number is taken concurrently by the plurality of cameras. The data capture can include a plurality of photographs each with at least 10 megapixels and wherein the plurality of constraints comprises each photograph having at least 75% overlap with another photograph. The data capture can include a video with at least 4k high definition and wherein the plurality of constraints can include capturing a screen from the video as a photograph having at least 75% overlap with another photograph captured from the video. The plurality of constraints can include a plurality of flight paths around the cell tower with each of the plurality of flight paths at one or more of different elevations and each of the plurality of cameras with different camera angles and different focal lengths.

In another exemplary embodiment, an apparatus adapted to obtain data capture at a cell site for developing a three dimensional (3D) thereof includes a network interface and a processor communicatively coupled to one another; and memory storing instructions that, when executed, cause the processor to cause the UAV to fly a given flight path about a cell tower at the cell site; obtain data capture during the flight path about the cell tower, wherein the data capture comprises a plurality of photos or video subject to a plurality of constraints, wherein the plurality of photos are obtained by a plurality of cameras which are coordinated with one another; and process the obtained data capture to define a

three dimensional (3D) model of the cell site based on one or more objects of interest in the data capture.

In a further exemplary embodiment, an Unmanned Aerial Vehicle (UAV) adapted to obtain data capture at a cell site for developing a three dimensional (3D) thereof includes one or more rotors disposed to a body; a plurality of cameras associated with the body; wireless interfaces; a processor coupled to the wireless interfaces and the camera; and memory storing instructions that, when executed, cause the processor to fly the UAV about a given flight path about a cell tower at the cell site; obtain data capture during the flight path about the cell tower, wherein the data capture comprises a plurality of photos or video, wherein the plurality of photos are obtained by a plurality of cameras which are coordinated with one another; and provide the obtained data for a server to process the obtained data capture to define a three dimensional (3D) model of the cell site based on one or more objects of interest in the data capture.

§ 22.0 Multiple Camera Apparatus and Process

Referring to FIGS. 53 and 54, in an exemplary embodiment, diagrams illustrate a multiple camera apparatus 2000 and use of the multiple camera apparatus 2000 in the shelter or cabinet 52 or the interior 900 of the building 902. As previously described herein, the camera 930 can be used in the interior 900 for obtaining photos for 3D modeling and for virtual site surveys. The multiple camera apparatus 2000 is an improvement to the camera 930, enabling multiple photos to be taken simultaneously of different views, angles, zoom, etc. In an exemplary embodiment, the multiple camera apparatus 2000 can be operated by a technician at the building 902 to quickly, efficiently, and properly obtain photos for a 3D model of the interior 900. In another exemplary embodiment, the multiple camera apparatus 2000 can be mounted in the interior 900 and remotely controlled by an operator.

The multiple camera apparatus 2000 includes a post 2002 with a plurality of cameras 2004 disposed or attached to the post 2002. The plurality of cameras 2004 can be interconnected to one another and to a control unit 2006 on the post. The control unit 2006 can include user controls to cause the cameras 2004 to each take a photo and memory for storing the photos from the cameras 2004. The control unit 2006 can further include communication mechanisms to provide the captured photos to a system for 3D modeling (either via a wired and/or wireless connection). In an exemplary embodiment, the post 2002 can be about 6' and the cameras 2004 can be positioned to enable data capture from the floor to the ceiling of the interior 900.

The multiple camera apparatus 2000 can include other physical embodiments besides the post 2002. For example, the multiple camera apparatus 2000 can include a box with the multiple cameras 2004 disposed therein. In another example, the multiple camera apparatus 2000 can include a handheld device which includes the multiple cameras 2004.

The objective of the multiple camera apparatus 2000 is to enable a technician (either on-site or remote) to quickly capture photos (through use of the multiple cameras 2004) for a 3D model and to properly capture the photos (through the multiple cameras 2004 having different zooms, angles, etc.). That is, the multiple camera apparatus 2000 ensures the photo capture is sufficient to accurately develop the 3D model, avoiding potentially revisiting the building 902.

Referring to FIG. 55, in an exemplary embodiment, a flowchart illustrates a data capture method 2050 in the interior 900 using the multiple camera apparatus 2000. The method 2050 includes obtaining or providing the multiple camera apparatus 2000 at the shelter or cabinet 52 or the

interior 900 of the building 902 and positioning the multiple camera apparatus 2000 therein (step 2052). The method 2050 further includes causing the plurality of cameras 2004 to take photos based on the positioning (step 2054) and repositioning the multiple camera apparatus 2000 at a different location in the shelter or cabinet 52 or the interior 900 of the building 902 to take additional photos (step 2056). Finally, the photos taken by the cameras 2004 are provided to a 3D modeling system to develop a 3D model of the shelter or cabinet 52 or the interior 900 of the building 902, such as for a virtual site survey (step 2058).

The repositioning step 2056 can include moving the multiple camera apparatus to each corner of the shelter, the cabinet, or the interior of the building. The repositioning step 2056 can include moving the multiple camera apparatus to each row of equipment in the shelter, the cabinet, or the interior of the building. The multiple camera apparatus can include a pole with the plurality of cameras disposed thereon, each of the plurality of cameras configured for a different view. The plurality of cameras are communicatively coupled to a control unit for the causing step 2054 and/or the providing step 2058. Each of the plurality of cameras can be configured on the multiple camera apparatus for a different view, zoom, and/or angle. The method 2050 can include analyzing the photos subsequent to the repositioning; and determining whether the photos are suitable for the 3D model, and responsive to the photos not being suitable for the 3D model, instructing a user to retake the photos which are not suitable. The method 2050 can include combining the photos of the shelter, the cabinet, or the interior of the building with photos of a cell tower at the cell site, to form a 3D model of the cell site. The method 2050 can include performing a virtual site survey of the cell site using the 3D model. The repositioning step 2056 can be based on a review of the photos taken in the causing step 2054.

In a further exemplary embodiment, a method for obtaining data capture at a cell site for developing a three dimensional (3D) thereof includes obtaining or providing the multiple camera apparatus comprising a plurality of cameras at a shelter, a cabinet, or an interior of a building and positioning the multiple camera apparatus therein; causing the plurality of cameras to simultaneously take photos based on the positioning; repositioning the multiple camera apparatus at a different location in the shelter, the cabinet, or the interior of the building to take additional photos; obtaining exterior photos of a cell tower connect to the shelter, the cabinet, or the interior of the building; and providing the photos taken by the multiple camera apparatus and the exterior photos to a 3D modeling system to develop a 3D model of the cell site, for a virtual site survey thereof.

§ 23.0 Cell Site Verification Using 3D Modeling

Referring to FIG. 56, in an exemplary embodiment, a flowchart illustrates a method 2100 for verifying equipment and structures at the cell site 10 using 3D modeling. As described herein, an intermediate step in the creation of a 3D model includes a point cloud, e.g., a sparse or dense point cloud. A point cloud is a set of data points in some coordinate system, e.g., in a three-dimensional coordinate system, these points are usually defined by X, Y, and Z coordinates, and can be used to represent the external surface of an object. Here, the object can be anything associated with the cell site 10, e.g., the cell tower 12, the cell site components 14, etc. As part of the 3D model creation process, a large number of points on an object's surface are determined, and the output is a point cloud in a data file. The point cloud represents the set of points that the device has measured.

Various descriptions were presented herein for site surveys, close-out audits, etc. In a similar manner, there is a need to continually monitor the state of the cell site **10**. Specifically, as described herein, conventional site monitoring techniques typically include tower climbs. The UAV **50** and the various approaches described herein provide safe and more efficient alternatives to tower climbs. Additionally, the UAV **50** can be used to provide cell site **10** verification to monitor for site compliance, structural or load issues, defects, and the like. The cell site **10** verification can utilize point clouds to compare “before” and “after” data capture to detect differences.

With respect to site compliance, the cell site **10** is typically owned and operated by a cell site operator (e.g., real estate company or the like) separate from cell service providers with their associated cell site components **14**. The typical transaction includes leases between these parties with specific conditions, e.g., number of antennas, amount of equipment, location of equipment, etc. It is advantageous for cell site operators to periodically audit/verify the state of the cell site **10** with respect to compliance, i.e., has cell service provider A added more cell site components **14** than authorized? Similarly, it is important for cell site operators to periodically check the cell site **10** to proactively detect load issues (too much equipment on the structure of the cell tower **12**), defects (equipment detached from the structure), etc.

One approach to verifying the cell site **10** is a site survey, including the various approaches to site surveys described herein, including use of 3D models for remote site surveys. In various exemplary embodiments, the method **2100** provides a quick and automated mechanism to quickly detect concerns (i.e., compliance issues, defects, load issues, etc.) using point clouds. Specifically, the method **2100** includes creating an initial point cloud for a cell site **10** or obtaining the initial point cloud from a database (step **2102**). The initial point cloud can represent a known good condition, i.e., with no compliance issues, load issues, defects, etc. For example, the initial point cloud could be developed as part of the close-out audit, etc. The initial point cloud can be created using the various data acquisition techniques described herein using the UAV **50**. Also, a database can be used to store the initial point cloud.

The initial point cloud is loaded in a device, such as the UAV **50** (step **2104**). The point cloud data files can be stored in the memory in a processing device associated with the UAV **50**. In an exemplary embodiment, multiple point cloud data files can be stored in the UAV **50**, allowing the UAV **50** to be deployed to perform the method **2100** at a plurality of cell sites **10**. The device (UAV **50**) can be used to develop a second point cloud based on current conditions at the cell site **10** (step **2106**). Again, the UAV **50** can use the techniques described herein relative to data acquisition to develop the second point cloud. Note, it is preferable to use a similar data acquisition for both the initial point cloud and the second point cloud, e.g., similar takeoff locations/orientations, similar paths about the cell tower **12**, etc. This ensures similarity in the data capture. In an exemplary embodiment, the initial point cloud is loaded to the UAV **50** along with instructions on how to perform the data acquisition for the second point cloud. The second point cloud is developed at a current time, i.e., when it is desired to verify aspects associated with the cell site **10**.

Variations are detected between the initial point cloud and the second point cloud (step **2108**). The variations could be detected by the UAV **50**, in an external server, in a database, etc. The objective here is the initial point cloud and the

second point cloud provide a quick and efficient comparison to detect differences, i.e., variations. The method **2100** includes determining if the variations are any of compliance related, load issues, or defects (step **2110**). Note, variations can be simply detected based on raw data differences between the point clouds. The step **2110** requires additional processing to determine what the underlying differences are. In an exemplary embodiment, the variations are detected in the UAV **50**, and, if detected, additional processing is performed by a server to actually determine the differences based on creating a 3D model of each of the point clouds. Finally, the second point cloud can be stored in the database for future processing (step **2112**). An operator of the cell site **10** can be notified via any technique of any determined variations or differences for remedial action based thereon (addressing non-compliance, performing maintenance to fix defects or load issues, etc.).

Although the present disclosure has been illustrated and described herein with reference to preferred embodiments and specific examples thereof, it will be readily apparent to those of ordinary skill in the art that other embodiments and examples may perform similar functions and/or achieve like results. All such equivalent embodiments and examples are within the spirit and scope of the present disclosure, are contemplated thereby, and are intended to be covered by the following claims.

What is claimed is:

1. A method for verifying a cell site, the method comprising the steps of:
 - storing, in a database, an initial point cloud related to at least a cell tower at the cell site and cell equipment attached to the cell tower;
 - developing a second point cloud based on current conditions of at least the cell tower and cell equipment at the cell site, wherein the second point cloud is based on data acquisition using an Unmanned Aerial Vehicle (UAV) at the cell site;
 - detecting variations between the initial point cloud and the second point cloud; and
 - responsive to detecting the variations, determining whether the variations are indicative of compliance related issues, wherein the compliance related issues are defined as an unauthorized amount of the cell equipment attached to the cell tower or the cell equipment being improperly attached to the cell tower.
2. The method of claim 1, further comprising the step of: creating the initial point cloud by using the UAV to perform a data acquisition technique; and providing the initial point cloud from the database to the UAV.
3. The method of claim 2, further comprising the step of: providing the data acquisition technique to the UAV with the initial point cloud to instruct the UAV to utilize the same data acquisition technique to develop the second point cloud.
4. The method of claim 1, wherein the step of detecting the variations is performed in the UAV, and wherein the step of determining whether the variations are indicative of compliance related issues is performed in an external server.
5. The method of claim 1, wherein the initial point cloud is created in a close out audit using the UAV to establish a known good condition whereby the cell equipment and cell tower include no compliance related issues.

53

6. The method of claim 1, further comprising the step of: notifying an operator associated with the cell site of any compliance related issues associated with the cell equipment and cell tower at the cell site for remedial action based thereon.

7. The method of claim 1, wherein the initial point cloud and the second point cloud are created in a similar manner by the UAV using flight characteristics comprising one or more of launch location, launch orientation, flight path, number of flights about the cell site, and speed of the flights.

8. An Unmanned Aerial Vehicle (UAV) configured to verify a cell site, the UAV comprising:

- one or more rotors;
- a wireless interface;
- a data store;
- a processor communicatively coupled to the one or more rotors, the data store, and the wireless interface; and memory storing instructions that, when executed, cause the processor to:
 - store, in the data store, an initial point cloud related to at least a cell tower at the cell site and cell equipment attached to the cell tower;
 - develop a second point cloud based on current conditions of at least the cell tower and cell equipment at the cell site, wherein the second point cloud is based on data acquisition using the UAV to fly at the cell site;
 - detect variations between the initial point cloud and the second point cloud; and
 - responsive to detecting the variations, perform one of i) determining whether the variations are indicative of compliance related issues, wherein the compliance related issues are defined as an unauthorized amount of cell equipment attached to the cell tower or the

54

cell equipment being improperly attached to the cell tower, and ii) providing the second point cloud to a server to determine whether the variations are indicative of the compliance related issues.

9. The UAV of claim 8, wherein the instructions, when executed, further cause the processor to:

- create the initial point cloud by using the UAV to perform a data acquisition technique; and
- provide the initial point cloud from an external database to the data store.

10. The UAV of claim 9, wherein the data acquisition technique is provided with the initial point cloud to instruct the UAV to utilize the same data acquisition technique to detect the second point cloud.

11. The UAV of claim 8, wherein the UAV is configured to detect the variations, and wherein an external server is configured to determine whether the variations are indicative of compliance related issues.

12. The UAV of claim 8, wherein the initial point cloud is created in a close out audit using the UAV to establish a known good condition whereby the cell equipment and cell tower include no compliance related issues.

13. The UAV of claim 8, wherein the instructions, when executed, further cause the processor to:

- notify an operator associated with the cell site of the any compliance related issues associated with the cell equipment and cell tower at the cell site for remedial action based thereon.

14. The UAV of claim 8, wherein the initial point cloud and the second point cloud are created in a similar manner by the UAV using flight characteristics comprising one or more of launch location, launch orientation, flight path, number of flights about the cell site, and speed of the flights.

* * * * *