

(12) **United States Patent**
Li

(10) **Patent No.:** **US 7,735,772 B2**
(45) **Date of Patent:** ***Jun. 15, 2010**

(54) **PERSONAL PROPULSION DEVICE**

(76) Inventor: **Raymond Li**, 1 Balmoral Place, St. John's, NL A1A 4P4 (CA)

(*) Notice: Subject to any disclaimer, the term of this patent is extended or adjusted under 35 U.S.C. 154(b) by 397 days.

This patent is subject to a terminal disclaimer.

(21) Appl. No.: **11/789,552**

(22) Filed: **Apr. 25, 2007**

(65) **Prior Publication Data**

US 2008/0156942 A1 Jul. 3, 2008

Related U.S. Application Data

(63) Continuation of application No. 11/088,330, filed on Mar. 23, 2005, now Pat. No. 7,258,301.

(60) Provisional application No. 60/556,396, filed on Mar. 26, 2004, provisional application No. 60/581,438, filed on Jun. 22, 2004.

(51) **Int. Cl.**

B64C 29/00 (2006.01)
B64C 39/02 (2006.01)
B63C 11/46 (2006.01)

(52) **U.S. Cl.** **244/4 A; 114/315; 440/38**

(58) **Field of Classification Search** **244/4 A, 244/2, 12.5, 17.17, 52; 114/315, 337; 440/38, 440/23**

See application file for complete search history.

(56) **References Cited**

U.S. PATENT DOCUMENTS

1,833,354 A 12/1931 Bauer

2,461,347 A	2/1949	Pentecost
2,509,603 A	5/1950	Marin
2,920,841 A	1/1960	Junker
3,021,095 A	2/1962	Moore
3,023,980 A	3/1962	Wain et al.
3,149,798 A	9/1964	Moore
3,176,984 A	4/1965	Sullivan
3,243,144 A	3/1966	Hulbert et al.
3,245,637 A	4/1966	Eickmann
3,277,858 A	10/1966	Athey
3,381,917 A	5/1968	Moore et al.
3,443,775 A	5/1969	William
3,474,987 A	10/1969	Meditz
3,503,574 A	3/1970	Eickmann
3,556,438 A	1/1971	Meditz
3,570,785 A	3/1971	Croft et al.
3,586,263 A	6/1971	Payne
3,614,024 A	10/1971	Millman
3,700,172 A	10/1972	Gallegos
4,040,577 A *	8/1977	Moore 244/4 A

(Continued)

Primary Examiner—Tien Dinh
Assistant Examiner—Joseph W Sanderson
(74) *Attorney, Agent, or Firm*—Christopher & Weisberg, P.A.

(57) **ABSTRACT**

The present invention provides a personal propulsion device including a body unit having a center of gravity, where the body unit includes a thrust assembly providing a main conduit in fluid communication with at least two thrust nozzles, with the thrust nozzles being located above the center of gravity of the body unit. The thrust nozzles are independently pivotable about a transverse axis located above the center of gravity, and may be independently controlled by a single common linkage. The present invention may further include a base unit having an engine and a pump, which provides pressurized fluid to the body unit through a delivery conduit in fluid communication with both the base unit and the thrust assembly.

13 Claims, 6 Drawing Sheets

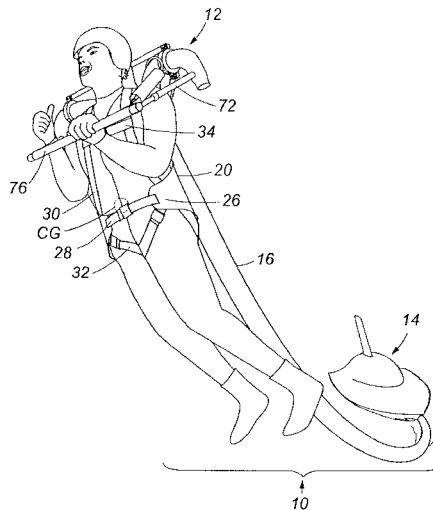

US 7,735,772 B2

Page 2

U.S. PATENT DOCUMENTS				5,679,035 A *	10/1997	Jordan	440/47
4,348,976 A *	9/1982	Gilbert 114/55.51	5,779,188 A	7/1998	Frick		
3,417,706 A	11/1983	Miller		6,488,232 B2	12/2002	Moshier		
4,541,357 A	9/1985	Stanton						
4,738,212 A *	4/1988	Schweitzer 114/313					* cited by examiner

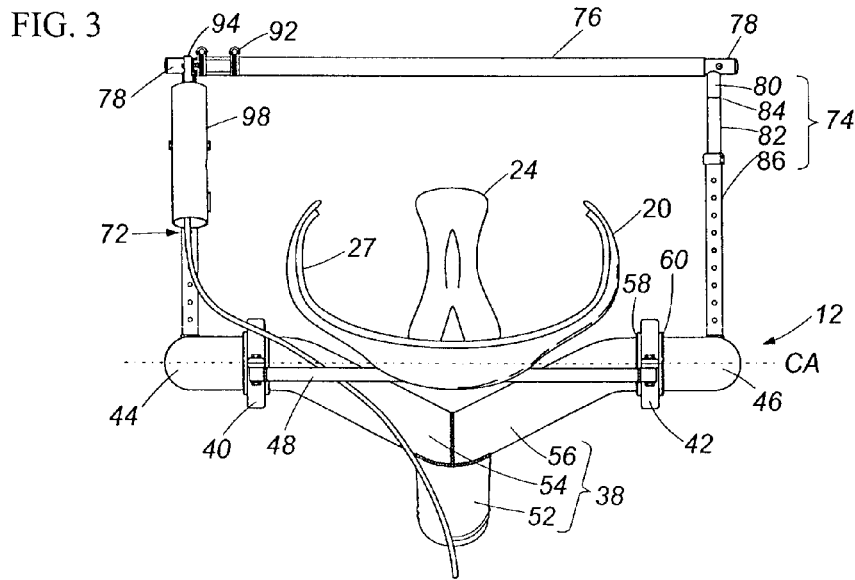
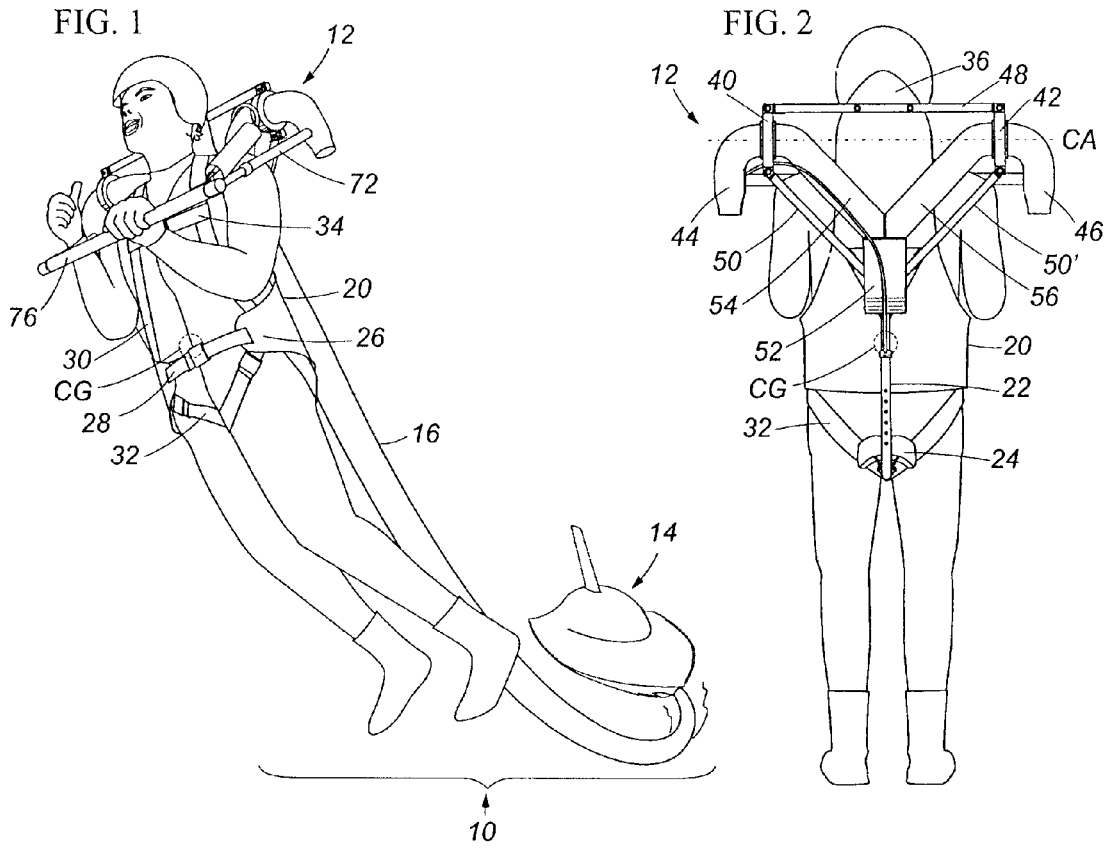

FIG. 4

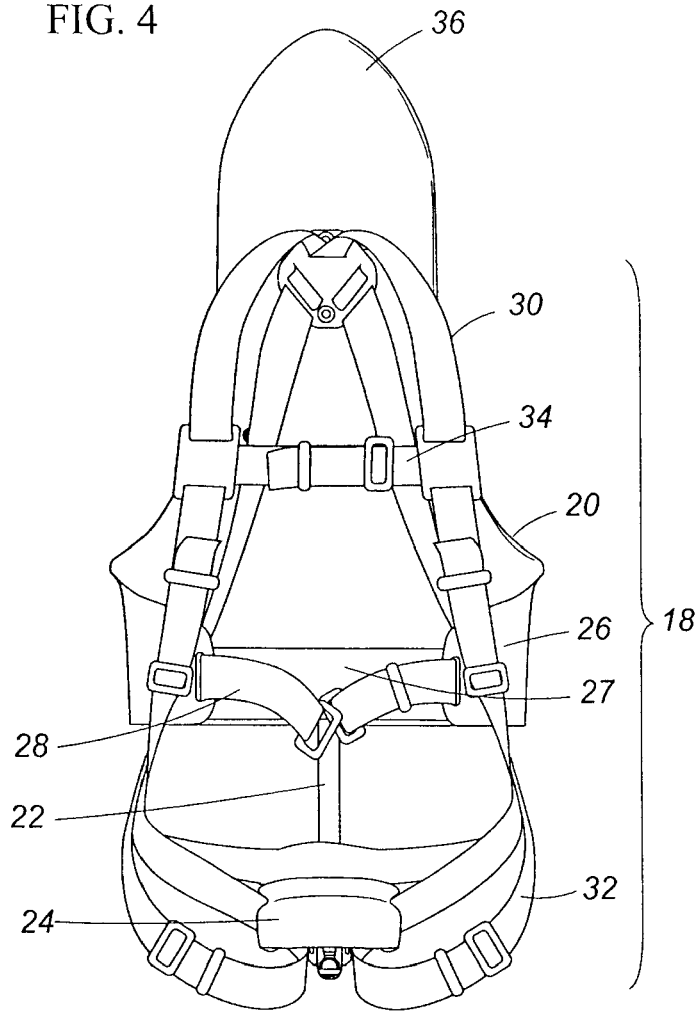

FIG. 8

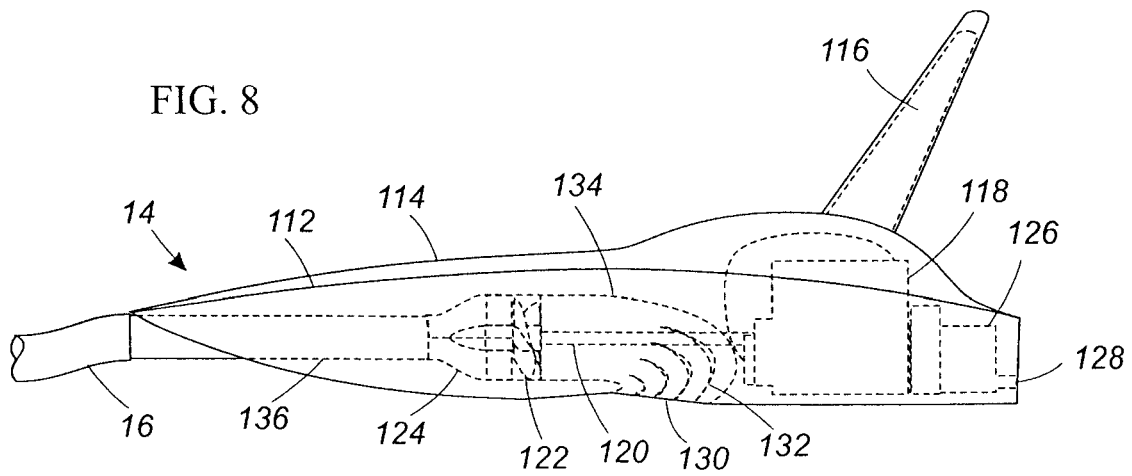

FIG. 5

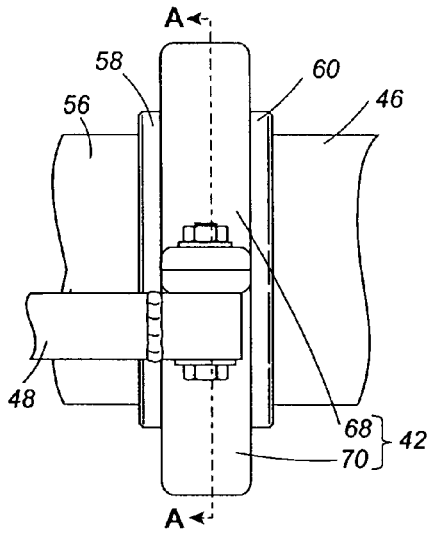

FIG. 6

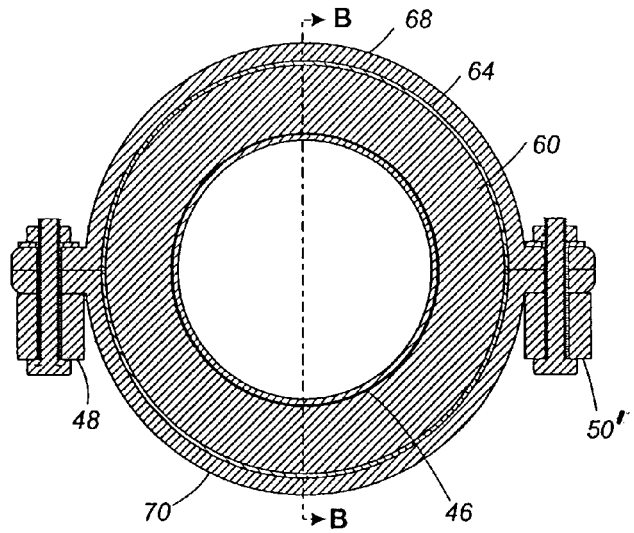

FIG. 7

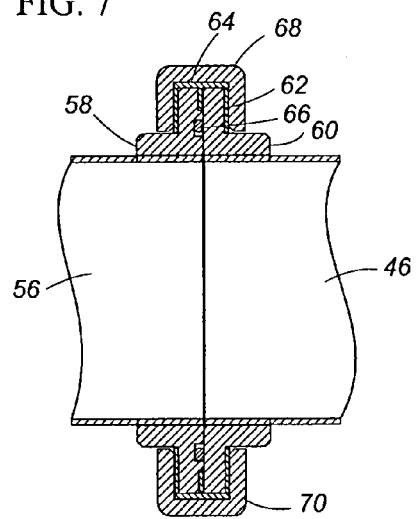

FIG. 9

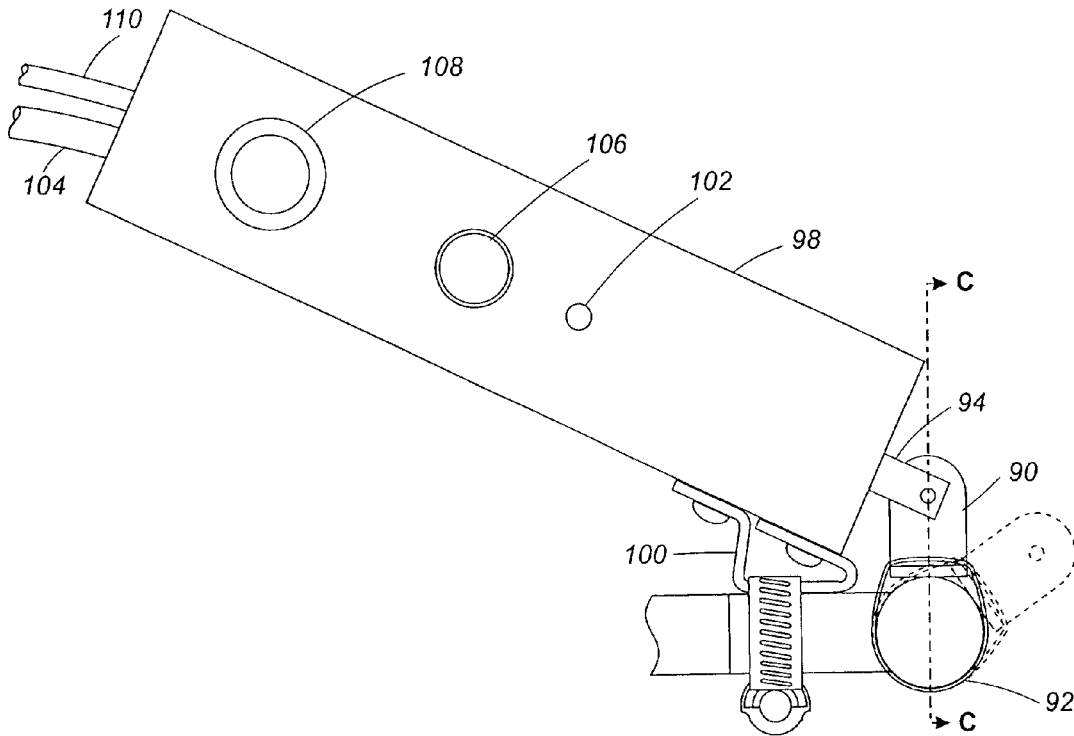
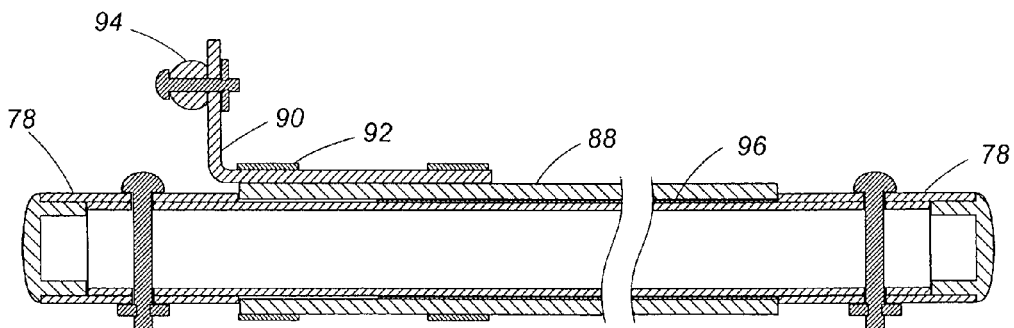

FIG. 10



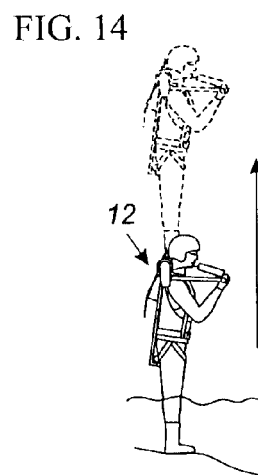
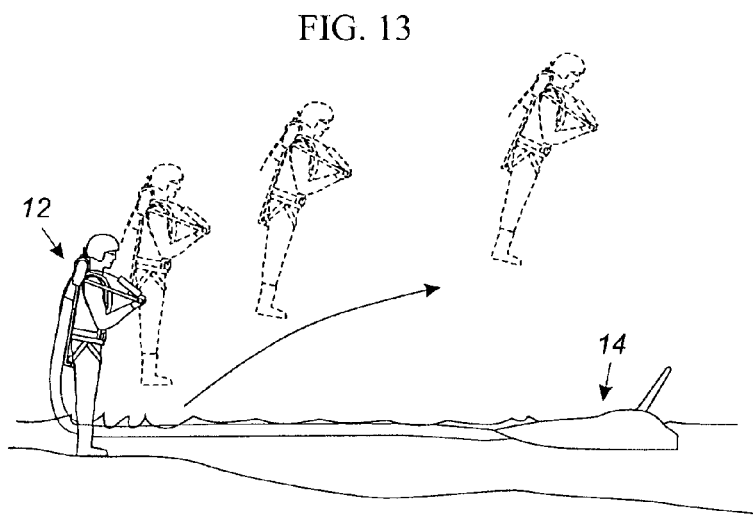
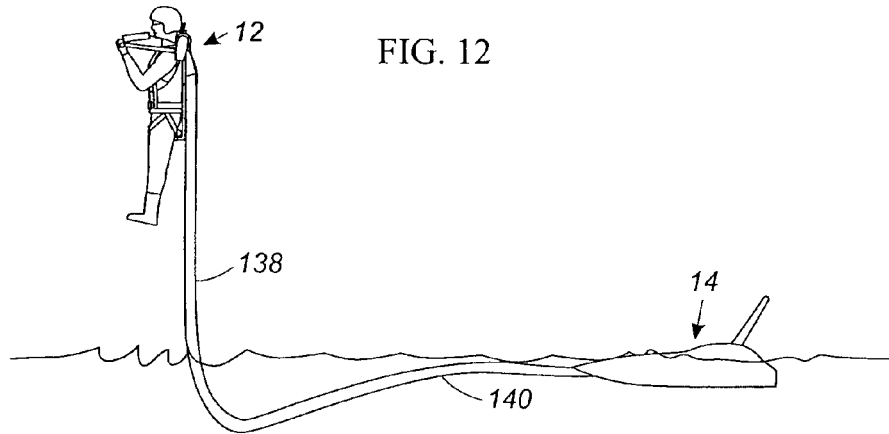
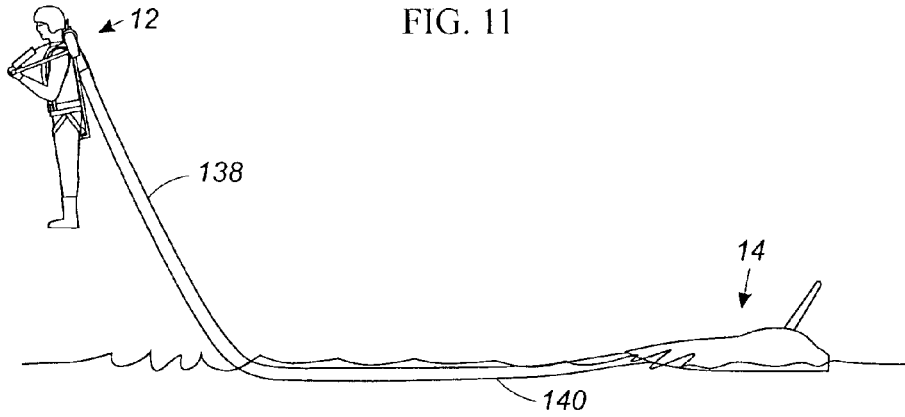

FIG. 15

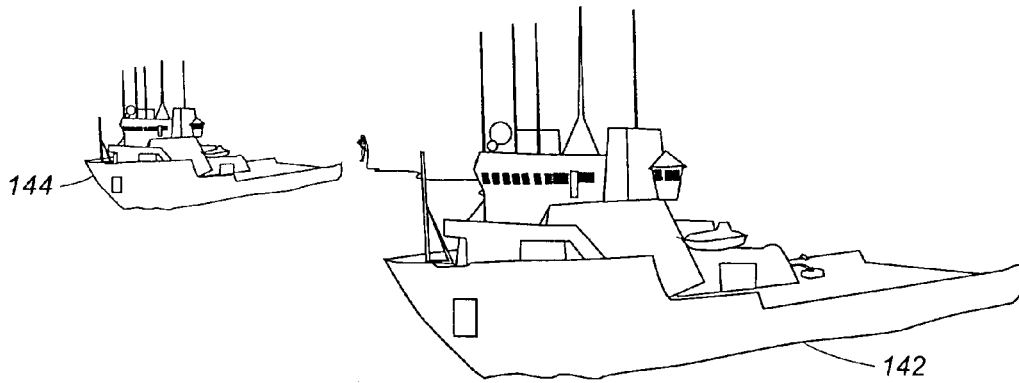

FIG. 16

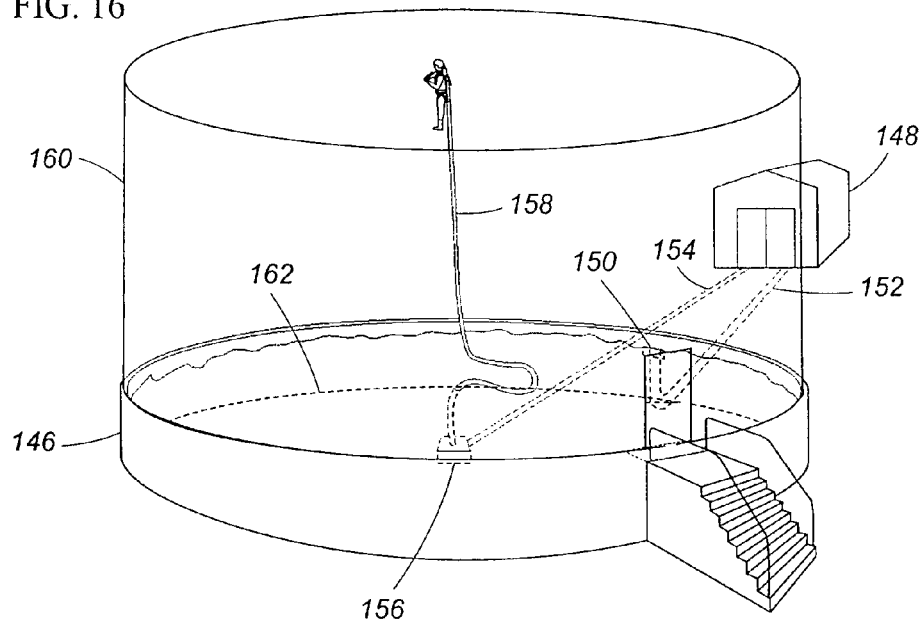
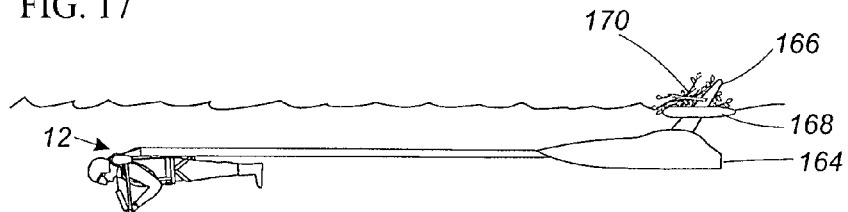

FIG. 17



PERSONAL PROPULSION DEVICE**CROSS-REFERENCE TO RELATED APPLICATION**

This application is a continuation of U.S. Utility patent application Ser. No. 11/088,330, filed Mar. 23, 2005, now U.S. Pat. No. 7,258,301 by Raymond Li, entitled PERSONAL PROPULSION DEVICE, now allowed, which application is related to and claims priority to U.S. Provisional Patent Application Ser. No. 60/556,396, filed Mar. 26, 2004, entitled PERSONAL PROPULSION DEVICE, which application is related to U.S. Provisional Patent Application Ser. No. 60/581,438, filed Jun. 22, 2004, entitled PERSONAL PROPULSION DEVICE, the entirety of which is incorporated herein by reference.

STATEMENT REGARDING FEDERALLY SPONSORED RESEARCH OR DEVELOPMENT

n/a

FIELD OF THE INVENTION

The present invention relates to powered flight, more specifically, to a personal propulsion device.

BACKGROUND OF THE INVENTION

Personal flight has been an eternal dream and a recent reality. However, unlike birds, human beings have a low power-to-weight ratio, and personal flight has only been accomplished by developing machines using powerful engines and aerodynamic lifting surfaces, such as autogyro aircraft, fixed wing airplanes, and helicopters. Arguably, the closest experience to that of individual, unrestricted flight has been attained through the use of single passenger devices, consisting mainly of a flight pack or similar structure that fits on or around the torso of an individual.

Typically, flight packs include propulsion devices such as propellers, rotor blades, or rockets, which often require a highly flammable fuel in order to generate sufficient thrust for flight. In addition to having a reservoir of volatile fluid attached to the body of a pilot, the close proximity of the propeller, rotor blades, or rocket exhaust to the pilot further poses significant safety risks. Another drawback of such self-contained, single-passenger flight packs is that the pilot must support the entire weight of both the airframe and fuel on his back, which can be highly uncomfortable and places severe limits on operation duration and range. Moreover, the location of thrust forces and the weight distribution of the fuel and accompanying components in such designs increase instability during take-off and for the duration of the flight.

Existing single passenger devices suffer an additional major drawback, in that the fuselage, engine, electrical equipment, fuel, and flight instrumentation are all part of the aircraft. As a result of the added weight of these systems, a significant amount of engine output and fuel is required to generate sufficient thrust to achieve flight. This necessitates larger and heavier engines and, even then, the power-to-weight ratio is often quite low.

As an alternative to employing the combustion of volatile fluids to directly generate thrust, the high-pressurization of non-flammable fluids, such as water, has been proposed to create sufficient thrust in order to achieve flight. While the use of pressurized water may significantly reduce the above-mentioned safety risks, even water-propelled devices still have

drawbacks in that the pressurization source must be carried into the air along with the fuselage and accompanying systems, contributing to a low power-to-weight ratio, and requiring larger engines in order to generate sufficient thrust.

It would be desirable to provide a single passenger aircraft that is safe, stable, and achieves a higher power-to-weight ratio than typical single-passenger devices. Moreover, it would be desirable to provide a single passenger aircraft that provides maneuverability, vertical takeoff and landing, as well as practical flight range and duration.

SUMMARY OF THE INVENTION

The present invention provides a personal propulsion device having a body unit, a base unit, and a delivery conduit in fluid communication with both the body unit and the base unit. The body unit may include a thrust assembly having at least two independently pivotable thrust nozzles, as well as a single linkage that accomplishes the pivoting movement. The nozzles are located above a center of gravity for the body unit, which provides inherent stability when the personal propulsion device is in use. The body unit may further include buoyant characteristics, as well as throttle controls and the like.

The base unit can include a wave-piercing hull that encloses an engine and a pump, which provides pressurized fluid to the delivery conduit. The delivery conduit subsequently delivers the pressurized fluid to the body unit, in order to provide sufficient thrust to lift the body unit and an operator into the air.

BRIEF DESCRIPTION OF THE DRAWINGS

A more complete understanding of the present invention, and the attendant advantages and features thereof, will be more readily understood by reference to the following detailed description when considered in conjunction with the accompanying drawings wherein:

FIG. 1 illustrates a personal propulsion device in accordance with the present invention;

FIG. 2 is a rear view of a personal propulsion device in accordance with the present invention;

FIG. 3 is a top view of a personal propulsion device in accordance with the present invention;

FIG. 4 is a front view of a harness system of a personal propulsion device in accordance with the present invention;

FIG. 5 is a top view of a swivel housing of a personal propulsion device in accordance with the present invention;

FIG. 6 is a cross sectional view of the swivel housing at line A-A of FIG. 5;

FIG. 7 is a cross sectional view of the swivel housing at line B-B of FIG. 6;

FIG. 8 is a side view of a pump vessel in accordance with the present invention;

FIG. 9 is a side view of an engine control module in accordance with the present invention;

FIG. 10 is a cross sectional view of the cross arm with throttle twist grip at line C-C in FIG. 9;

FIG. 11 is an illustration of a personal propulsion device in forward flight in accordance with the present invention;

FIG. 12 is an illustration of a personal propulsion device in hover flight in accordance with the present invention;

FIG. 13 is an illustration of a takeoff with forward translation of a personal propulsion device from shallow water in accordance with the present invention;

FIG. 14 is an illustration of a vertical takeoff of a personal propulsion device in accordance with the present invention;

FIG. 15 is an illustration of a method using a personal propulsion device in accordance with the present invention;

FIG. 16 shows a pond or pool-based embodiment of a personal propulsion device in accordance with the present invention; and

FIG. 17 depicts an alternative use of a personal propulsion device in accordance with the present invention.

DETAILED DESCRIPTION OF THE INVENTION

Now referring to FIGS. 1 through 4, an exemplary embodiment of the present invention provides a personal propulsion device 10 having a body unit 12, a base unit 14 capable of providing pressurized fluid flow, and a delivery conduit 16 in fluid communication with both the body unit 12 and the base unit 14.

The body unit 12 includes a body harness system 18 having a torso corset 20, a seat post 22 and a saddle 24. The torso corset 20 may have a modified barrel shape, contoured to provide firm support, protection and comfort for the torso, while further transmitting the lifting and gravity forces to an operator. While the torso corset 20 is preferably made of a generally rigid material such as fiberglass-reinforced plastic, the torso corset 20 may include flexible extension flaps 26 that wrap around the waist of an operator. An extension flap cushioning 27 may be attached to the extension flaps 26, thereby providing a band of foam-like material that cushions and supports the weight of the body unit 12 and the body harness system 18 on the hip bone of an operator. The body harness system 18 can further include a waist strap 28, shoulder straps 30, groin straps 32, and a chest strap 34 to hold an operator in place. Furthermore, a corset extension 36 provides protection for the rear regions of the operator's head and neck. The torso corset 20 and harness system 18 provide rigidity to the body unit 12 for improved stability, provide protection and comfort to the operator, and distribute a substantial amount of the operator's bodyweight over a wide area including the torso, groin and buttocks areas. In addition to promoting stability, the torso corset 20 and the accompanying straps and cushioning can be made from a buoyant material sufficient to keep the body unit 12 and an operator of at least 200 pounds afloat in a body of water for a prolonged period of time.

The seat post 22 and the saddle 24 of the body unit 12 support part of the weight of the operator and, in addition to the rigidity provided by the harness system 18, further reduce unnecessary movements and oscillations of the lower torso of an operator which can destabilize the body unit 12 during flight. The weight of the operator is distributed over the saddle 24, the groin straps 32, as well as over the contact surfaces with the torso corset 20 and the body harness system 18.

As shown in FIGS. 1-3, the body unit 12 has a thrust assembly having a supply conduit assembly 38, left swivel housing 40, right swivel housing 42, left thrust nozzle 44, and right thrust nozzle 46. Each swivel housing is affixed to or is integral with an upper support arm 48 and a pair of lower support arms 50, 50', with both the upper and lower support arms being affixed to the torso corset 20 in order to transmit lift and propulsion forces. The supply conduit assembly 38 further includes a medially located and vertically disposed main conduit 52 that rises from about mid-back level and branches into a left bifurcation conduit 54 and a right bifurcation conduit 56. Both bifurcated conduits course upward and forward to terminate in flanges 58, which are pivotally mounted inside both the left swivel housing 40 and the right swivel housing 42. The bifurcated conduits are preferably made from 3.00" outside diameter rigid tubing, while the

main conduit 52 is preferably made from 4" outside diameter rigid tubing, with the upper end formed to join smoothly with the bifurcated conduits.

The left thrust nozzle 44 and right thrust nozzle 46 are pivotally attached to the swivel housings 40, 42 with flanges 60 matching the bifurcated conduits' flanges 58. As shown in FIGS. 5 through 7, multiple washers 62 made of a low-friction material, and a strip 64 around the perimeter of the flanges, reduce friction between the flanges' contact surfaces inside each swivel housing. An O-ring 66 seated in a groove between the flanges further provides a seal against fluid leaks. The flanges 58, 60 and washers 62 are housed inside both swivel housings 40, 42. The swivel housings 40, 42 each further include a front housing element 68 and a rear housing element 70. The swivel housings provide the ability of both the thrust nozzles as well as the main conduit to pivot about a centerline axis "CA" extending through the swivel housings.

Now referring to FIG. 3, the body unit 12 further includes a port side control arm assembly 72 and a starboard side control arm assembly 74, both of which are attached to thrust nozzles 44 and 46 respectively. A cross arm 76 connects the control arm assemblies 72, 74 at their outer ends. Control arm assemblies 72, 74 each include a cross arm collar 78, which is affixed to an outer control arm 80. The outer control arm 80 is further connected to a mid control arm 82, with an extension spring 84 attached to their inner walls. The mid control arm 82 is connected to an inner control arm 86 with an adjustable telescoping mechanism, and the inner control arm 86 is attached to the front surface of the thrust nozzles 44 and 46. By moving the cross arm 76 in an up-and-down direction, the operator can deflect both control arm assemblies 72, 74 together, which in turn deflect the thrust nozzles 44, 46 together to vary the allocation between lift and propulsion force vectors. The flexible articulation at the extension spring 84 allows the operator to deflect port and starboard thrust nozzles 44, 46 by different amounts, thus generating yaw control moments. Moreover, this flexibility provides independent control of either nozzle through a single common linkage, i.e., the cross arm 76. Roll control is not often required in a wingless flight device, but the operator can affect roll control by shifting weight from side-to-side within the body harness system 18. The static and dynamic friction of the thrust nozzles' swivel mechanism are intended to maintain any set deflection position, in order to allow hands-free hovering and to prevent accidental loss of control should the operator release his grip on the cross arm 76.

Now referring to FIGS. 9 and 10, the body unit 12 can include a twist grip control that allows throttle control to be integrated with the cross arm 76. The twist grip control includes a twist grip 88 extends across a substantial length of the cross arm 76, in order to allow the pilot to operate the twist grip control with either one or both hands. A crank 90 is affixed to the end of the twist grip 88 by a clamp 92, and is further pivotally connected to a throttle control master cylinder piston 94. To facilitate free deflection of the twist grip 88, a plastic sleeve 96 can be included to reduce the friction between the twist grip and the inner core of the cross arm 76.

Referring now to FIGS. 3 and 9, a control housing 98 can be affixed to the outer control arm 80 with an angled bracket 100. When the twist grip 88 is rotated by the operator, it deflects the crank 90, which pushes or pulls the throttle control master cylinder piston 94 in a master cylinder (not shown) inside the control housing 98. The master cylinder movements are transmitted by hydraulic pressure along hydraulic tubing 104 to an engine compartment in the base unit 14, where it actuates a dual-action throttle actuator piston to move the throttle crank on an engine. As a result, actuation of the twist grip 88 on the

body unit 12 is communicated to the base unit 14, which can result in subsequent modification of the fluid flow provided by the base unit 14. The throttle control mechanism is intended to maintain any set position in order to maintain flight dynamics should the operator release his grip on the cross arm 76. The control housing 98 can also include a start/stop electric control 106 and an engine overheat warning buzzer 108, both of which communicate with the base unit 14 through a multi-lead electric cable 110. Where necessary, additional gauges or monitors for navigation purposes and for monitoring base unit performance may also be located in the control housing 98. The hydraulic tubing 104 and multi-lead electric cable 110 may be integrated with the delivery conduit 16 in order to achieve communication with the base unit 14.

The thrust assembly of the body unit 12 provides lightweight, simple, reliable and stable control for the personal propulsion device 10. When dry, the body unit 12 exerts little weight on the pilot. Moreover, simple mechanical devices provide the pilot with thrust mechanisms as well as pitch, roll and yaw controls. No engine, transmission, or propeller-type devices are located on the body unit 12, the absence of which provides simplicity as well as reliability and safety in the operation of the personal propulsion device 10.

The body unit 12 includes a center of gravity "CG" when in use, where, in an exemplary embodiment of the present invention, the dual thrust nozzles 44 and 46 generate nozzle reaction forces for lift and propulsion at a point well above the center of gravity "CG." By positioning the nozzles above the center of gravity "CG," a significant portion of the forces acting on the body unit, i.e., lift, propulsion, steering, gravity, tension in the delivery conduit, etc., converge normally to the centerline axis "CA" about which the thrust nozzles 44 and 46 and the supply conduit assembly 38 deflect, thereby isolating a substantial amount of the destabilizing forces and moments from the operator. Moreover, as an operator in body unit 12 ascends to greater heights, the weight of fluid moving through the delivery conduit provides greater stability as the weight of the entrained fluid further offsets any destabilizing forces or movements that an operator may experience.

In an exemplary embodiment, as shown in FIG. 8, the base unit 14 includes a hull 112, a water-tight deck 114 and a snorkel mast 116 for engine air and ventilation. The engine 118 is located towards the aft portion of the base unit 14, and powers a drive shaft 120 that rotates an impeller 122 in a pump 124. The engine 118 inducts air through an air passage in the snorkel mast 116, and exhaust gases pass through a noise reduction muffler 126 and subsequently exit through an exhaust port 128 located in the stem.

When the engine 118 is in operation, water is inducted through a water intake 130, past stationary guide vanes 132 that divert the water flow forward through a pump intake channel 134 into the pump 124, where the impeller 122 transfers energy to the water to increase its speed and pressure. Pressurized water exits through a bow discharge conduit 136, where the pressurized water flow proceeds into the delivery conduit 16. The delivery conduit 16 provides the pressurized water flow to the main conduit 52 of the body unit 12, where the flow is routed to the left and right thrust nozzles 44 and 46. The engine 118 preferably generates sufficient pressurization of the water exiting the bow discharge conduit 136 such that the fluid mass flow rate at the left and right nozzles of the body unit 12 generate sufficient thrust to lift approximately 200 pounds or more a height of 30 feet for a sustained period of time.

The base unit 14 is intended to be adaptable for a wide variety of applications, and may include variations in form. For example, the base unit 14 may have a wave-piercing hull

in order to minimize the possibility of becoming airborne due to large waves. Such activity could interrupt water intake in the base unit 14, resulting in lost thrust in the body unit 12 and the potential for rapid descent of an operator. A wave-piercing hull would ensure that rather than elevating above a large wave, the base unit 14 would pierce or pass through a portion of a wave, thereby remaining in contact with the water and preventing any interruption of fluid flow to the body unit 12.

The delivery conduit 16 is preferably a large diameter hose, i.e., four inches or more, having a lightweight polyester jacket and extruded polyurethane lining. This construction provides sufficient tensile strength for towing the base unit 14, as well as low internal friction, kink resistance, abrasion and chemical resistance, ultraviolet light resistance, high burst strength, and minimal stretching or warping under pressure. In addition to minimizing friction with the pressurized water flow, the delivery conduit also provides additional weight with the entrained water such that flight stability is increased when the personal propulsion device is in operation. Moreover, hydraulic control tubing and control cables may be housed in a flexible protective rubber sheath affixed along a surface of the delivery conduit 16.

By separating the fuselage, engine, pump, electrical system, cooling system, lubrication system, and fuel system of a typical aircraft and instead supporting these systems independently in the base unit 14 on land or water, a very large percentage of the potential weight of the body unit 12 is eliminated. Instead, power is delivered to the body unit 12 through the delivery conduit 16, which carries water from the base unit 14 to the body unit 12. This arrangement allows a relatively small engine to generate sufficient lift and propulsion for the body unit 12, and enables the personal propulsion device 10 to operate with much higher efficiency, more maneuverability, and longer range and flight duration.

Potential applications for the personal propulsion device 10 include a recreational and rescue vehicle, a ship-based mobile vessel system for duties at sea; a land-based fixed system for amusement rides, demonstrations and training; and a stealth mobile vessel system optimized for low-detection underwater travel for law enforcement and military applications.

Referring now to FIGS. 11 and 12, an exemplary embodiment includes using the personal propulsion device 10 over water, wherein the base unit 14 is mobile and is towed along by the thrust generated at the body unit 12. During flight, a section 138 of the delivery conduit 16 is suspended in the air by the lift from the body unit 12. The remaining portion 140 of the delivery conduit 16 between the suspended section and the base unit 14 floats near the surface of the water through natural buoyancy and hydrodynamic lift. In forward flight, the suspended section 138 of the delivery conduit 16 is slanted due to tension between the forward thrust of the body unit 12 and water resistance on the hull 112 of the base unit 14. In hover mode, gravity pulls down on the suspended section 138 of the delivery conduit 16 so that it is almost vertical. The weight of entrained water pulls a section 140 of the hose under water, and provides hover stability to the body unit 12 by offsetting a constant airborne mass against a constant lift from nozzle reaction forces.

FIG. 13 illustrates a takeoff of the body unit 12 with forward translation. Shallow water may be preferred for performing most takeoffs and landings, although takeoffs from deep water, shores, dock structures or from aboard another vessel are equally possible. Upon deploying the base unit 14 on the water and starting the engine 118, the operator increases the throttle and as lift is felt, he trims the thrust nozzle angles to provide maximum lift and minimal forward

propulsion. After takeoff, the pilot continues to increase throttle and at the same time deflect the thrust nozzles rearwards to initiate forward flight. Forward thrust may also be enhanced kinesthetically by pitching the upper torso forward. When in forward flight, the base unit **14** is passively propelled by tension originating from the body unit **12** through the delivery conduit **16** and is slowed down rapidly from water resistance as tension in the delivery conduit **16** is reduced or changes direction. Although not illustrated, alternative embodiments may incorporate active propulsion for the base unit **14** in both forward and reverse directions, in response to flight control commands initiated by the operator on the body unit **12**.

Now referring to FIG. **14**, in order to hover with the personal propulsion device **10**, the operator increases the throttle and at the same time trims the thrust nozzle angles for maximum lift and neutral horizontal propulsion, and continues increasing the throttle until the desired altitude has been reached.

As shown in FIG. **15**, the personal propulsion device may be used as a ship-based means for transporting personnel or cargo from one ship to another. In such an embodiment, a large multi-purpose pump on a supply or rescue vessel **142** supplies the power for lift and propulsion through the delivery conduit **16**, which may have an increased diameter for this particular application, to the body unit **12** as previously described. Repair and maintenance work can be performed on the vessel, and human and cargo payloads can be transferred between the supply ship **142** and another vessel **144**, even in relatively rough sea conditions where other methods of transfer may be too dangerous.

Now referring to FIG. **16**, an alternative embodiment of use for the personal propulsion device **10** providing a land-based application. In this alternative embodiment, a pond or pool **146** provides a safe and restricted access area for operation. A powerful pump preferably located in a pump house **148** draws in water from near the surface of the pond or pool through a skimmer **150** and a supply duct **152** (shown in this embodiment as buried underground). The water is then pumped through a conduit **154** (also shown in this embodiment as buried underground) to a base **156** at the bottom of the center of the pond or pool **146**, then subsequently through a hose **158** to the body unit **12**. In this particular embodiment, the water flow at the thrust nozzles may be controlled by a flow regulating device located in a main conduit of the body unit **12**. An exterior enclosure **160** may be included to restrict the flight area, and a submerged safety net **162** can provide a safe base for takeoffs and landings. This pond or pool-based embodiment can be installed anywhere with access to a water supply, and hence can be deployed in high traffic amusement parks, next to major traffic arterials, and in gathering areas where a natural body of water is not available. This embodiment is especially useful for marketing, demonstrations, training, pilot certification, and as a paid admission amusement ride.

In yet another embodiment of the present invention an operator can use the personal propulsion device **10** for travel in both air and water. As shown in FIG. **17**, an alternative embodiment of the present invention provides for low-detection travel under water. Assisted by an underwater breathing apparatus or snorkel equipment, the operator can travel underwater for long distances with water jet propulsion from a ballasted base unit **164**. A snorkel mast **116** is fitted with ports and passages for engine air intake and exhaust, and a

floatation chamber **168** operates to keep the snorkel ports above the waterline when the base unit **164** is under tow. Camouflage material **170** such as an artificial waterfowl or floating debris may be affixed to the snorkel tower **166** to disguise the tower and the wakes generated when traveling. This embodiment may be favorably employed in military and law enforcement applications where both stealth and airborne mobility are important for approaching floating or near shore targets.

It will be appreciated by persons skilled in the art that the present invention is not limited to what has been particularly shown and described herein above. In addition, unless mention was made above to the contrary, it should be noted that all of the accompanying drawings are not to scale. A variety of modifications and variations are possible in light of the above teachings without departing from the scope and spirit of the invention, which is limited only by the following claims.

What is claimed is:

1. A personal propulsion device, comprising:

a body unit having a center of gravity, wherein the body unit includes a thrust assembly having at least two thrust nozzles located above the center of gravity, the thrust nozzles being pivotally coupled to the body unit;

a delivery conduit in fluid communication with the thrust assembly; and

a base unit in fluid communication with the delivery conduit, the base unit capable of delivering pressurized fluid to the delivery conduit, wherein during operation the body unit is independently movable with respect to the base unit and capable of flight.

2. The personal propulsion device according to claim 1, wherein the at least two thrust nozzles are independently pivotable.

3. The personal propulsion device according to claim 2, wherein the at least two thrust nozzles are independently pivotable about a transverse axis located above the center of gravity of the body unit.

4. The personal propulsion device according to claim 2, wherein the body unit further includes a single common linkage coupled to the at least two thrust nozzles to accomplish pivoting.

5. The personal propulsion device according to claim 1, wherein the body unit further includes a throttle in communication with the base unit for regulating the flow of pressurized fluid to the delivery conduit.

6. The personal propulsion device according to claim 1, wherein the body unit is buoyant.

7. The personal propulsion device according to claim 1, wherein the thrust assembly further includes a main conduit, wherein the main conduit is in fluid communication with the at least two thrust nozzles and the delivery conduit.

8. The personal propulsion device according to claim 7, wherein the main conduit is pivotable.

9. The personal propulsion device according to claim 8, wherein the main conduit is pivotable about a transverse axis above the center of gravity of the body unit.

10. The personal propulsion device according to claim 1, wherein the base unit includes a pump, the pump being in fluid communication with the delivery conduit.

11. The personal propulsion device according to claim 1, wherein the delivery conduit is a flexible hose.

12. A personal propulsion device, comprising:

a body unit having a center of gravity, wherein the body unit includes a thrust assembly having a main conduit and at least two thrust nozzles independently pivotable with respect to each other located above the center of gravity, and wherein the main conduit and the at least

9

two thrust nozzles are independently pivotable about a transverse axis located above the center of gravity of the body unit;
a delivery conduit coupled to the main conduit; and
a base unit in fluid communication with the delivery conduit, the base unit capable of delivering pressurized fluid to the delivery conduit, wherein during operation the

10

body unit is independently movable with respect to the base unit.

13. The personal propulsion device according to claim 12, wherein at least a portion of the delivery conduit is pivotable about the transverse axis located above the center of gravity of the body unit.

* * * * *



US007735772C1

(12) **EX PARTE REEXAMINATION CERTIFICATE** (10822nd)
United States Patent
Li

(10) **Number:** **US 7,735,772 C1**
(45) **Certificate Issued:** ***Feb. 24, 2016**

- (54) **PERSONAL PROPULSION DEVICE**
- (75) Inventor: **Raymond Li**, St. John's (CA)
- (73) Assignee: **JLIP, LLC**, Dania Beach, FL (US)

Reexamination Request:
No. 90/013,433, Jan. 28, 2015

Reexamination Certificate for:
Patent No.: **7,735,772**
Issued: **Jun. 15, 2010**
Appl. No.: **11/789,552**
Filed: **Apr. 25, 2007**

(*) Notice: This patent is subject to a terminal disclaimer.

Related U.S. Application Data

- (63) Continuation of application No. 11/088,330, filed on Mar. 23, 2005, now Pat. No. 7,258,301.
- (60) Provisional application No. 60/556,396, filed on Mar. 26, 2004, provisional application No. 60/581,438, filed on Jun. 22, 2004.

- (51) **Int. Cl.**
B64C 29/00 (2006.01)
B64C 39/02 (2006.01)
B63C 11/46 (2006.01)
B63H 11/00 (2006.01)
H03K 5/08 (2006.01)
H03H 11/12 (2006.01)

- (52) **U.S. Cl.**
CPC **H03K 5/086** (2013.01); **H03H 11/1286** (2013.01); **H03H 11/1291** (2013.01)
- (58) **Field of Classification Search**
USPC 285/121.7, 145.2, 148.13, 148.15, 114, 285/115, 238, 272
See application file for complete search history.

(56) **References Cited**

To view the complete listing of prior art documents cited during the proceeding for Reexamination Control Number 90/013,433, please refer to the USPTO's public Patent Application Information Retrieval (PAIR) system under the Display References tab.

Primary Examiner — Aaron J Lewis

(57) **ABSTRACT**

The present invention provides a personal propulsion device including a body unit having a center of gravity, where the body unit includes a thrust assembly providing a main conduit in fluid communication with at least two thrust nozzles, with the thrust nozzles being located above the center of gravity of the body unit. The thrust nozzles are independently pivotable about a transverse axis located above the center of gravity, and may be independently controlled by a single common linkage. The present invention may further include a base unit having an engine and a pump, which provides pressurized fluid to the body unit through a delivery conduit in fluid communication with both the base unit and the thrust assembly.

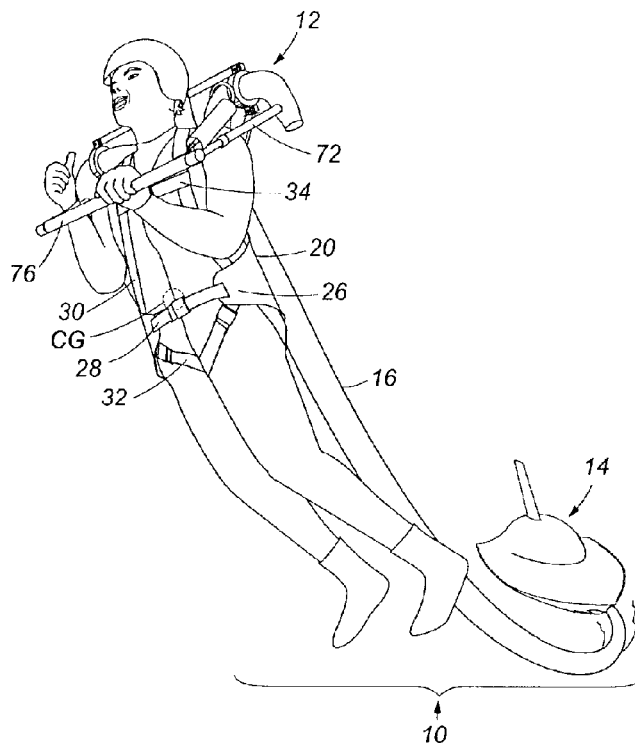

1

**EX PARTE
REEXAMINATION CERTIFICATE**

THE PATENT IS HEREBY AMENDED AS
INDICATED BELOW.

Matter enclosed in heavy brackets [] appeared in the patent, but has been deleted and is no longer a part of the patent; matter printed in italics indicates additions made to the patent.

AS A RESULT OF REEXAMINATION, IT HAS BEEN DETERMINED THAT:

Claims 1, 5 and 12 are determined to be patentable as amended.

Claims 2-4, 6-11 and 13, dependent on an amended claim, are determined to be patentable.

New claims 14-85 are added and determined to be patentable.

1. A personal propulsion device, comprising:

a body unit having a center of gravity, wherein the body unit includes a thrust assembly having at least two thrust nozzles located above the center of gravity, the thrust nozzles being pivotally coupled to the body unit and configured to generate thrust to directly lift the body unit;

a delivery conduit in fluid communication with the thrust assembly; and

a base unit in fluid communication with the delivery conduit, the base unit capable of delivering pressurized [fluid] water to the delivery conduit, wherein during operation the body unit is independently movable with respect to the base unit and capable of flight.

5. The personal propulsion device according to claim 1, wherein the body unit further includes a throttle in communication with the base unit for regulating the flow of pressurized [fluid] water to the delivery conduit.

12. A personal propulsion device, comprising:

a body unit having a center of gravity, wherein the body unit includes a thrust assembly having a main conduit and at least two thrust nozzles independently pivotable with respect to each other located above the center of gravity, and wherein the main conduit and the at least two thrust nozzles are independently pivotable about a transverse axis located above the center of gravity of the body unit;

a delivery conduit coupled to the main conduit; and

a base unit in fluid communication with the delivery conduit, the base unit capable of delivering pressurized [fluid] water to the delivery conduit, wherein during operation the body unit is independently movable with respect to the base unit.

14. *The device according to claim 1, wherein the body unit is configured to attach to a person's torso.*

15. *The device according to claim 1, wherein the body unit includes a navigation gauge or monitor.*

16. *The device according to claim 1, wherein the body unit includes a gauge or monitor configured to monitor base unit performance.*

17. *The device according to claim 1, wherein the thrust assembly includes a main conduit that branches into two conduits, and wherein the main conduit has an outside diameter of at least four inches.*

2

18. *The device according to claim 1, wherein the body unit includes a control arm coupled to the thrust assembly, wherein the control arm includes an adjustable telescoping mechanism.*

5 19. *The device according to claim 1, wherein the at least two thrust nozzles are configured to maintain any set deflection position.*

20. *The device according to claim 1, wherein the at least two thrust nozzles are independently controllable.*

10 21. *The device according to claim 1, wherein the base unit is a watercraft.*

22. *The device according to claim 1, wherein the base unit is a mobile waterborne vessel.*

15 23. *The device according to claim 1, wherein the base unit is a vessel configured to transport personnel.*

24. *The device according to claim 1, wherein the base unit is a vessel configured to transport cargo.*

25. *The device according to claim 1, wherein the base unit is a supply vessel.*

20 26. *The device according to claim 1, wherein the base unit is a rescue vessel.*

27. *The device according to claim 1, wherein the base unit defines a wave-piercing hull.*

25 28. *The device according to claim 1, wherein the base unit includes a snorkel mast.*

29. *The device according to claim 1, wherein the base unit includes camouflage material.*

30 30. *The device according to claim 1, wherein the base unit is configured to deliver pressurized water to the thrust assembly sufficient to generate thrust to directly lift 200 pounds a height of 30 feet for a sustained period of time.*

31. *A personal propulsion device, comprising: a body unit having a center of gravity, wherein the body unit includes a thrust assembly having at least two thrust nozzles located above the center of gravity, the thrust nozzles being pivotally coupled to the body unit and configured to discharge a pressurized fluid to directly lift the body unit; a delivery conduit in fluid communication with the thrust assembly; and a mobile waterborne base unit in fluid communication with the delivery conduit, the base unit configured to deliver pressurized fluid to the delivery conduit, wherein during operation the body unit is independently movable with respect to the base unit and capable of flight.*

45 32. *The personal propulsion device according to claim 31, wherein the at least two thrust nozzles are independently pivotable.*

50 33. *The personal propulsion device according to claim 31, wherein the at least two thrust nozzles are configured to discharge a pressurized fluid to directly lift the body unit and an operator.*

34. *The personal propulsion device according to claim 31, wherein the at least two thrust nozzles are independently pivotable about a transverse axis located above the center of gravity of the body unit.*

55 35. *The personal propulsion device according to claim 34, wherein the body unit further includes a single common linkage coupled to the at least two thrust nozzles to accomplish pivoting.*

60 36. *The personal propulsion device according to claim 31, wherein the body unit further includes a throttle in communication with the base unit for regulating the flow of pressurized fluid to the delivery conduit.*

37. *The personal propulsion device according to claim 31, wherein the body unit is buoyant.*

65 38. *The personal propulsion device according to claim 31, wherein the thrust assembly further includes a main conduit,*

wherein the main conduit is in fluid communication with the at least two thrust nozzles and the delivery conduit.

39. The personal propulsion device according to claim 38, wherein the main conduit is pivotable.

40. The personal propulsion device according to claim 39, wherein the main conduit is pivotable about a transverse axis above the center of gravity of the body unit.

41. The personal propulsion device according to claim 31, wherein the base unit includes a water pump, the water pump being in fluid communication with the delivery conduit.

42. The personal propulsion device according to claim 31, wherein the delivery conduit is a flexible hose.

43. The device according to claim 31, wherein the body unit is configured to attach to a person's torso.

44. The device according to claim 31, wherein the body unit includes a navigation gauge or monitor.

45. The device according to claim 31, wherein the body unit includes a gauge or monitor configured to monitor base unit performance.

46. The device according to claim 31, wherein the thrust assembly includes a main conduit that branches into two conduits, and wherein the main conduit has an outside diameter of at least four inches.

47. The device according to claim 31, wherein the body unit includes a control arm coupled to the thrust assembly, wherein the control arm includes an adjustable telescoping mechanism.

48. The device according to claim 31, wherein the at least two thrust nozzles are configured to maintain any set deflection position.

49. The device according to claim 31, wherein the at least two thrust nozzles are independently controllable.

50. The device according to claim 31, wherein the base unit is a vessel configured to transport personnel.

51. The device according to claim 31, wherein the base unit is a vessel configured to transport cargo.

52. The device according to claim 31, wherein the base unit is a supply vessel.

53. The device according to claim 31, wherein the base unit is a rescue vessel.

54. The device according to claim 31, wherein the base unit defines a wave-piercing hull.

55. The device according to claim 31, wherein the base unit includes a snorkel mast.

56. The device according to claim 31, wherein the base unit includes camouflage material.

57. The device according to claim 31, wherein the base unit is configured to deliver pressurized water to the thrust assembly.

58. The device according to claim 57, wherein the base unit is configured to deliver pressurized water to the thrust assembly sufficient to generate thrust to directly lift 200 pounds a height of 30 feet for a sustained period of time.

59. A personal propulsion device, comprising: a body unit having a center of gravity, wherein the body unit includes a thrust assembly having at least two thrust nozzles located above the center of gravity, the thrust nozzles being pivotally coupled to the body unit, wherein the thrust nozzles are independently pivotable with respect to each other; a delivery conduit in fluid communication with the thrust assembly; and a waterborne base unit in fluid communication with the delivery conduit, the base unit configured to deliver pressurized fluid to the delivery conduit, wherein during operation the body unit is independently movable with respect to the base unit and capable of flight.

60. The personal propulsion device according to claim 59, wherein the at least two thrust nozzles are configured to discharge a pressurized fluid to directly lift the body unit and an operator.

61. The personal propulsion device according to claim 59, wherein the at least two thrust nozzles are independently pivotable about a transverse axis located above the center of gravity of the body unit.

62. The personal propulsion device according to claim 59, wherein the body unit further includes a single common linkage coupled to the at least two thrust nozzles to accomplish pivoting.

63. The personal propulsion device according to claim 59, wherein the body unit further includes a throttle in communication with the base unit for regulating the flow of pressurized fluid to the delivery conduit.

64. The personal propulsion device according to claim 59, wherein the body unit is buoyant.

65. The personal propulsion device according to claim 59, wherein the thrust assembly further includes a main conduit, wherein the main conduit is in fluid communication with the at least two thrust nozzles and the delivery conduit.

66. The personal propulsion device according to claim 65, wherein the main conduit is pivotable.

67. The personal propulsion device according to claim 66, wherein the main conduit is pivotable about a transverse axis above the center of gravity of the body unit.

68. The personal propulsion device according to claim 59, wherein the base unit includes a water pump, the water pump being in fluid communication with the delivery conduit.

69. The personal propulsion device according to claim 59, wherein the delivery conduit is a flexible hose.

70. The device according to claim 59, wherein the body unit is configured to attach to a person's torso.

71. The device according to claim 59, wherein the body unit includes a navigation gauge or monitor.

72. The device according to claim 59, wherein the body unit includes a gauge or monitor configured to monitor base unit performance.

73. The device according to claim 59, wherein the thrust assembly includes a main conduit that branches into two conduits, and wherein the main conduit has an outside diameter of at least four inches.

74. The device according to claim 59, wherein the body unit includes a control arm coupled to the thrust assembly, wherein the control arm includes an adjustable telescoping mechanism.

75. The device according to claim 59, wherein the at least two thrust nozzles are configured to maintain any set deflection position.

76. The device according to claim 59, wherein the at least two thrust nozzles are independently controllable.

77. The device according to claim 59, wherein the base unit is a vessel configured to transport personnel.

78. The device according to claim 59, wherein the base unit is a vessel configured to transport cargo.

79. The device according to claim 59, wherein the base unit is a supply vessel.

80. The device according to claim 59, wherein the base unit is a rescue vessel.

81. The device according to claim 59, wherein the base unit defines a wave-piercing hull.

82. The device according to claim 59, wherein the base unit includes a snorkel mast.

83. The device according to claim 59, wherein the base unit includes camouflage material.

84. The device according to claim 59, wherein the base unit is configured to deliver pressurized water to the thrust assembly.

85. The device according to claim 84, wherein the base unit is configured to deliver pressurized water to the thrust assembly sufficient to generate thrust to directly lift 200 pounds a height of 30 feet for a sustained period of time.

* * * * *