



US010107905B2

(12) **United States Patent**
Lynam

(10) **Patent No.:** **US 10,107,905 B2**
(45) **Date of Patent:** ***Oct. 23, 2018**

(54) **FORWARD FACING SENSING SYSTEM FOR VEHICLE**

(71) Applicant: **MAGNA ELECTRONICS INC.**,
Auburn Hills, MI (US)

(72) Inventor: **Niall R. Lynam**, Holland, MI (US)

(73) Assignee: **MAGNA ELECTRONICS INC.**,
Auburn Hills, MI (US)

(*) Notice: Subject to any disclaimer, the term of this patent is extended or adjusted under 35 U.S.C. 154(b) by 158 days.

This patent is subject to a terminal disclaimer.

(21) Appl. No.: **15/361,746**

(22) Filed: **Nov. 28, 2016**

(65) **Prior Publication Data**

US 2017/0074981 A1 Mar. 16, 2017

Related U.S. Application Data

(60) Continuation of application No. 15/149,338, filed on May 9, 2016, now Pat. No. 9,507,021, which is a (Continued)

(51) **Int. Cl.**
G01S 13/93 (2006.01)
G01S 13/86 (2006.01)

(Continued)

(52) **U.S. Cl.**
CPC **G01S 13/931** (2013.01); **B60T 7/22** (2013.01); **G01S 7/03** (2013.01); **G01S 7/032** (2013.01);

(Continued)

(58) **Field of Classification Search**
CPC G01S 13/86; G01S 13/867; G01S 13/931
See application file for complete search history.

(56) **References Cited**

U.S. PATENT DOCUMENTS

4,571,082 A 2/1986 Downs
4,572,619 A 2/1986 Reininger
(Continued)

FOREIGN PATENT DOCUMENTS

EP 1506893 2/2005
JP H05301541 11/1993

(Continued)

OTHER PUBLICATIONS

European Search Report for European Patent Application No. 08780377.1 dated Jun. 7, 2010.

(Continued)

Primary Examiner — Peter M Bythrow

(74) *Attorney, Agent, or Firm* — Honigman Miller Schwartz and Cohn, LLP

(57) **ABSTRACT**

A forward facing sensing system for a vehicle includes a radar sensor and an image sensor that sense and view forward of the vehicle. The radar sensor and the image sensor are housed in a self-contained unit disposed behind and attached at the vehicle windshield. A control includes an image processor operable to analyze image data captured by the image sensor in order to, at least in part, detect an object present exterior of the vehicle. The control, responsive at least in part to processing of captured image data and to sensing by the radar sensor, determines that a potentially hazardous condition may exist in the path of forward travel of the vehicle. The radar sensor and the image sensor collaborate in a way that enhances sensing capability of the sensing system for the object in the path of forward travel of the vehicle.

27 Claims, 2 Drawing Sheets

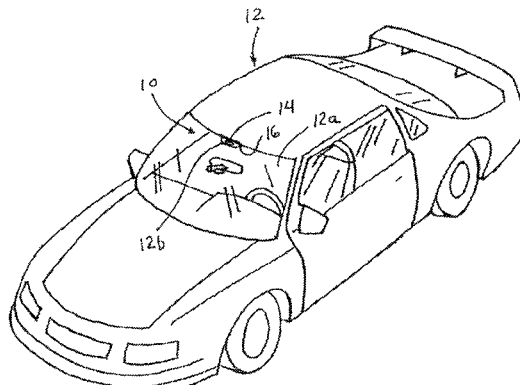

Related U.S. Application Data

continuation of application No. 15/005,092, filed on Jan. 25, 2016, now Pat. No. 9,335,411, which is a continuation of application No. 14/859,683, filed on Sep. 21, 2015, now Pat. No. 9,244,165, which is a continuation of application No. 14/107,624, filed on Dec. 16, 2013, now Pat. No. 9,140,789, which is a division of application No. 13/656,975, filed on Oct. 22, 2012, now Pat. No. 8,614,640, which is a continuation of application No. 13/540,856, filed on Jul. 3, 2012, now Pat. No. 8,294,608, which is a continuation of application No. 13/192,525, filed on Jul. 28, 2011, now Pat. No. 8,217,830, which is a continuation of application No. 12/524,446, filed as application No. PCT/US2008/051833 on Jan. 24, 2008, now Pat. No. 8,013,780.

(60) Provisional application No. 60/886,568, filed on Jan. 25, 2007.

(51) **Int. Cl.**

B60T 7/22 (2006.01)
G01S 17/02 (2006.01)
G01S 7/03 (2006.01)
G01S 13/02 (2006.01)

(52) **U.S. Cl.**

CPC **G01S 13/86** (2013.01); **G01S 13/867** (2013.01); **G01S 13/93** (2013.01); **G01S 17/023** (2013.01); **G01S 2013/0245** (2013.01); **G01S 2013/9321** (2013.01); **G01S 2013/9357** (2013.01); **G01S 2013/9392** (2013.01)

(56)

References Cited

U.S. PATENT DOCUMENTS

4,580,875 A 4/1986 Bechtel
 4,600,913 A 7/1986 Caine
 4,603,946 A 8/1986 Kato
 4,614,415 A 9/1986 Hyatt
 4,620,141 A 10/1986 McCumber et al.
 4,623,222 A 11/1986 Itoh
 4,626,850 A 12/1986 Chey
 4,629,941 A 12/1986 Ellis
 4,630,109 A 12/1986 Barton
 4,632,509 A 12/1986 Ohmi
 4,638,287 A 1/1987 Umebayashi et al.
 4,647,161 A 3/1987 Müller
 4,669,825 A 6/1987 Itoh
 4,669,826 A 6/1987 Itoh
 4,671,615 A 6/1987 Fukada
 4,672,457 A 6/1987 Hyatt
 4,676,601 A 6/1987 Itoh
 4,690,508 A 9/1987 Jacob
 4,692,798 A 9/1987 Seko et al.
 4,697,883 A 10/1987 Suzuki
 4,701,022 A 10/1987 Jacob
 4,713,685 A 12/1987 Nishimura et al.
 4,717,830 A 1/1988 Botts
 4,727,290 A 2/1988 Smith
 4,731,669 A 3/1988 Hayashi et al.
 4,741,603 A 5/1988 Miyagi
 4,768,135 A 8/1988 Kretschmer et al.
 4,789,904 A 12/1988 Peterson
 4,793,690 A 12/1988 Gahan
 4,817,948 A 4/1989 Simonelli
 4,820,933 A 4/1989 Hong
 4,825,232 A 4/1989 Howdle
 4,838,650 A 6/1989 Stewart
 4,847,772 A 7/1989 Michalopoulos et al.
 4,862,037 A 8/1989 Farber et al.
 4,867,561 A 9/1989 Fujii et al.

4,871,917 A 10/1989 O'Farrell et al.
 4,872,051 A 10/1989 Dye
 4,881,019 A 11/1989 Shiraiishi et al.
 4,882,565 A 11/1989 Gallmeyer
 4,886,960 A 12/1989 Molyneux
 4,891,559 A 1/1990 Matsumoto et al.
 4,892,345 A 1/1990 Rachael, III
 4,895,790 A 1/1990 Swanson et al.
 4,896,030 A 1/1990 Miyaji
 4,907,870 A 3/1990 Brucker
 4,910,591 A 3/1990 Petrossian et al.
 4,916,374 A 4/1990 Schierbeek
 4,917,477 A 4/1990 Bechtel et al.
 4,937,796 A 6/1990 Tendler
 4,943,796 A 7/1990 Lee
 4,953,305 A 9/1990 Van Lente et al.
 4,956,591 A 9/1990 Schierbeek
 4,961,625 A 10/1990 Wood et al.
 4,967,319 A 10/1990 Seko
 4,970,653 A 11/1990 Kenue
 4,971,430 A 11/1990 Lynas
 4,974,078 A 11/1990 Tsai
 4,987,357 A 1/1991 Masaki
 4,991,054 A 2/1991 Walters
 5,001,558 A 3/1991 Burley et al.
 5,003,288 A 3/1991 Wilhelm
 5,012,082 A 4/1991 Watanabe
 5,016,977 A 5/1991 Baude et al.
 5,027,001 A 6/1991 Torbert
 5,027,200 A 6/1991 Petrossian et al.
 5,044,706 A 9/1991 Chen
 5,055,668 A 10/1991 French
 5,059,877 A 10/1991 Teder
 5,064,274 A 11/1991 Alten
 5,072,154 A 12/1991 Chen
 5,086,253 A 2/1992 Lawler
 5,096,287 A 3/1992 Kakinami et al.
 5,097,362 A 3/1992 Lynas
 5,121,200 A 6/1992 Choi
 5,124,549 A 6/1992 Michaels et al.
 5,130,709 A 7/1992 Toyama et al.
 5,148,014 A 9/1992 Lynam
 5,168,378 A 12/1992 Black
 5,170,374 A 12/1992 Shimohigashi et al.
 5,172,235 A 12/1992 Wilm et al.
 5,177,685 A 1/1993 Davis et al.
 5,182,502 A 1/1993 Slotkowski et al.
 5,184,956 A 2/1993 Langlais et al.
 5,189,561 A 2/1993 Hong
 5,193,000 A 3/1993 Lipton et al.
 5,193,029 A 3/1993 Schofield
 5,204,778 A 4/1993 Bechtel
 5,208,701 A 5/1993 Maeda
 5,245,422 A 9/1993 Borcherts et al.
 5,253,109 A 10/1993 O'Farrell
 5,276,389 A 1/1994 Levers
 5,285,060 A 2/1994 Larson et al.
 5,289,182 A 2/1994 Brillard et al.
 5,289,321 A 2/1994 Secor
 5,305,012 A 4/1994 Faris
 5,307,136 A 4/1994 Saneyoshi
 5,309,137 A 5/1994 Kajiwara
 5,309,163 A 5/1994 Ngan et al.
 5,313,072 A 5/1994 Vachss
 5,325,096 A 6/1994 Pakett
 5,325,386 A 6/1994 Jewell et al.
 5,329,206 A 7/1994 Slotkowski et al.
 5,331,312 A 7/1994 Kudoh
 5,336,980 A 8/1994 Levers
 5,341,437 A 8/1994 Nakayama
 5,351,044 A 9/1994 Mathur et al.
 5,355,118 A 10/1994 Fukuhara
 5,374,852 A 12/1994 Parkes
 5,381,155 A 1/1995 Gerber
 5,386,285 A 1/1995 Asayama
 5,394,333 A 2/1995 Kao
 5,406,395 A 4/1995 Wilson et al.
 5,410,346 A 4/1995 Saneyoshi et al.
 5,414,257 A 5/1995 Stanton

(56)

References Cited

U.S. PATENT DOCUMENTS

5,414,461	A	5/1995	Kishi et al.	5,850,176	A	12/1998	Kinoshita et al.
5,416,313	A	5/1995	Larson et al.	5,850,254	A	12/1998	Takano et al.
5,416,318	A	5/1995	Hegyí	5,867,591	A	2/1999	Onda
5,416,478	A	5/1995	Morinaga	5,872,536	A	2/1999	Lyons et al.
5,424,952	A	6/1995	Asayama	5,877,707	A	3/1999	Kowalick
5,426,294	A	6/1995	Kobayashi et al.	5,877,897	A	3/1999	Schofield et al.
5,430,431	A	7/1995	Nelson	5,878,370	A	3/1999	Olson
5,434,407	A	7/1995	Bauer et al.	5,883,739	A	3/1999	Ashihara et al.
5,440,428	A	8/1995	Hegg et al.	5,884,212	A	3/1999	Lion
5,444,478	A	8/1995	Lelong et al.	5,890,021	A	3/1999	Onoda
5,451,822	A	9/1995	Bechtel et al.	5,896,085	A	4/1999	Mori et al.
5,457,493	A	10/1995	Leddy et al.	5,899,956	A	5/1999	Chan
5,461,357	A	10/1995	Yoshioka et al.	5,914,815	A	6/1999	Bos
5,461,361	A	10/1995	Moore	5,923,027	A	7/1999	Stam et al.
5,469,298	A	11/1995	Suman et al.	5,929,786	A	7/1999	Schofield et al.
5,471,515	A	11/1995	Fossum et al.	5,933,109	A	8/1999	Tohya et al.
5,475,494	A	12/1995	Nishida et al.	5,938,717	A	8/1999	Dunne et al.
5,498,866	A	3/1996	Bendicks et al.	5,940,120	A	8/1999	Frankhouse et al.
5,500,766	A	3/1996	Stonecypher	5,956,181	A	9/1999	Lin
5,510,983	A	4/1996	Iino	5,959,367	A	9/1999	O'Farrell et al.
5,515,042	A	5/1996	Nelson	5,959,555	A	9/1999	Furuta
5,515,448	A	5/1996	Nishitani	5,959,571	A	9/1999	Aoyagi et al.
5,521,633	A	5/1996	Nakajima et al.	5,963,247	A	10/1999	Banitt
5,528,698	A	6/1996	Kamei et al.	5,971,552	A	10/1999	O'Farrell et al.
5,529,138	A	6/1996	Shaw et al.	5,986,796	A	11/1999	Miles
5,530,240	A	6/1996	Larson et al.	5,990,469	A	11/1999	Bechtel et al.
5,530,420	A	6/1996	Tsuchiya et al.	5,990,649	A	11/1999	Nagao et al.
5,535,314	A	7/1996	Alves et al.	6,001,486	A	12/1999	Varaprasad et al.
5,537,003	A	7/1996	Bechtel et al.	6,020,704	A	2/2000	Buschur
5,539,397	A	7/1996	Asanuma et al.	6,049,171	A	4/2000	Stam et al.
5,541,590	A	7/1996	Nishio	6,057,754	A	5/2000	Kinoshita et al.
5,550,677	A	8/1996	Schofield et al.	6,066,933	A	5/2000	Ponziana
5,568,027	A	10/1996	Teder	6,067,110	A	5/2000	Nonaka et al.
5,574,443	A	11/1996	Hsieh	6,075,492	A	6/2000	Schmidt et al.
5,581,464	A	12/1996	Woll et al.	6,084,519	A	7/2000	Coulling et al.
5,585,798	A	12/1996	Yoshioka et al.	6,085,151	A	7/2000	Farmer et al.
5,594,222	A	1/1997	Caldwell	6,087,953	A	7/2000	DeLine et al.
5,614,788	A	3/1997	Mullins	6,097,024	A	8/2000	Stam et al.
5,619,370	A	4/1997	Guinosso	6,116,743	A	9/2000	Hoek
5,634,709	A	6/1997	Iwama	6,118,401	A	9/2000	Tognazzini
5,642,299	A	6/1997	Hardin et al.	6,118,410	A	9/2000	Nagy
5,648,835	A	7/1997	Uzawa	6,124,647	A	9/2000	Marcus et al.
5,650,944	A	7/1997	Kise	6,124,886	A	9/2000	DeLine et al.
5,657,021	A	8/1997	Ehsani-Nategh et al.	6,139,172	A	10/2000	Bos et al.
5,660,454	A	8/1997	Mori et al.	6,144,022	A	11/2000	Tenenbaum et al.
5,661,303	A	8/1997	Teder	6,172,613	B1	1/2001	DeLine et al.
5,666,028	A	9/1997	Bechtel et al.	6,175,164	B1	1/2001	O'Farrell et al.
5,668,663	A	9/1997	Varaprasad et al.	6,175,300	B1	1/2001	Kendrick
5,670,935	A	9/1997	Schofield et al.	6,198,409	B1	3/2001	Schofield et al.
5,677,851	A	10/1997	Kingdon et al.	6,201,642	B1	3/2001	Bos
5,699,044	A	12/1997	Van Lente et al.	6,216,540	B1	4/2001	Nelson et al.
5,715,093	A	2/1998	Schierbeek et al.	6,222,460	B1	4/2001	DeLine et al.
5,724,187	A	3/1998	Varaprasad et al.	6,243,003	B1	6/2001	DeLine et al.
5,724,316	A	3/1998	Brunts	6,250,148	B1	6/2001	Lynam
5,737,226	A	4/1998	Olson et al.	6,259,412	B1	7/2001	Duroux
5,760,826	A	6/1998	Nayer	6,266,082	B1	7/2001	Yonezawa et al.
5,760,828	A	6/1998	Cortes	6,266,442	B1	7/2001	Laumeyer et al.
5,760,931	A	6/1998	Saburi et al.	6,278,399	B1	8/2001	Ashihara
5,761,094	A	6/1998	Olson et al.	6,285,393	B1	9/2001	Shimoura et al.
5,765,116	A	6/1998	Wilson-Jones et al.	6,291,906	B1	9/2001	Marcus et al.
5,781,437	A	7/1998	Wiemer et al.	6,294,989	B1	9/2001	Schofield et al.
5,786,772	A	7/1998	Schofield et al.	6,297,781	B1	10/2001	Turnbull et al.
5,790,403	A	8/1998	Nakayama	6,302,545	B1	10/2001	Schofield et al.
5,790,973	A	8/1998	Blaker et al.	6,310,611	B1	10/2001	Caldwell
5,793,308	A	8/1998	Rosinski et al.	6,313,454	B1	11/2001	Bos et al.
5,793,420	A	8/1998	Schmidt	6,317,057	B1	11/2001	Lee
5,796,094	A	8/1998	Schofield et al.	6,320,282	B1	11/2001	Caldwell
5,798,575	A	8/1998	O'Farrell et al.	6,323,477	B1	11/2001	Blasing et al.
5,835,255	A	11/1998	Miles	6,326,613	B1	12/2001	Heslin et al.
5,837,994	A	11/1998	Stam et al.	6,329,925	B1	12/2001	Skiver et al.
5,844,505	A	12/1998	Van Ryzin	6,333,759	B1	12/2001	Mazzilli
5,844,682	A	12/1998	Kiyomoto et al.	6,341,523	B2	1/2002	Lynam
5,845,000	A	12/1998	Breed et al.	6,353,392	B1	3/2002	Schofield et al.
5,847,676	A	12/1998	Cole	6,366,213	B2	4/2002	DeLine et al.
5,848,802	A	12/1998	Breed et al.	6,370,329	B1	4/2002	Teuchert
				6,396,397	B1	5/2002	Bos et al.
				6,411,204	B1	6/2002	Bloomfield et al.
				6,411,328	B1	6/2002	Franke et al.
				6,420,975	B1	7/2002	DeLine et al.

(56)

References Cited

U.S. PATENT DOCUMENTS

6,424,273	B1	7/2002	Gutta et al.	6,879,281	B2	4/2005	Gresham et al.
6,428,172	B1	8/2002	Hutzel et al.	6,882,287	B2	4/2005	Schofield
6,430,303	B1	8/2002	Naoi et al.	6,889,161	B2	5/2005	Winner et al.
6,433,676	B2	8/2002	DeLine et al.	6,903,677	B2	6/2005	Takashima et al.
6,442,465	B2	8/2002	Breed et al.	6,909,753	B2	6/2005	Meehan et al.
6,452,148	B1	9/2002	Bendicks et al.	6,941,211	B1	9/2005	Kuroda et al.
6,462,700	B1	10/2002	Schmidt et al.	6,944,544	B1	9/2005	Prakah-Asante et al.
6,477,464	B2	11/2002	McCarthy et al.	6,946,978	B2	9/2005	Schofield
6,485,155	B1	11/2002	Duroux et al.	6,947,577	B2	9/2005	Stam et al.
6,492,935	B1	12/2002	Higuchi	6,953,253	B2	10/2005	Schofield et al.
6,497,503	B1	12/2002	Dassanayake et al.	6,958,729	B1	10/2005	Metz
6,498,620	B2	12/2002	Schofield et al.	6,968,736	B2	11/2005	Lynam
6,513,252	B1	2/2003	Schierbeek et al.	6,975,390	B2	12/2005	Mindl et al.
6,516,664	B2	2/2003	Lynam	6,975,775	B2	12/2005	Rykowski et al.
6,523,964	B2	2/2003	Schofield et al.	6,987,419	B2	1/2006	Gresham
6,534,884	B2	3/2003	Marcus et al.	6,999,024	B2	2/2006	Kumon et al.
6,539,306	B2	3/2003	Turnbull	7,004,593	B2	2/2006	Weller et al.
6,547,133	B1	4/2003	DeVries, Jr. et al.	7,004,606	B2	2/2006	Schofield
6,553,130	B1	4/2003	Lemelson et al.	7,005,974	B2	2/2006	McMahon et al.
6,555,804	B1	4/2003	Blasing	7,012,560	B2	3/2006	Braeuchle et al.
6,574,033	B1	6/2003	Chui et al.	7,038,577	B2	5/2006	Pawlicki et al.
6,580,385	B1	6/2003	Winner et al.	7,042,389	B2	5/2006	Shirai
6,589,625	B1	7/2003	Kothari et al.	7,062,300	B1	6/2006	Kim
6,593,565	B2	7/2003	Heslin et al.	7,065,432	B2	6/2006	Moisel et al.
6,594,583	B2	7/2003	Ogura et al.	7,085,637	B2	8/2006	Breed et al.
6,611,202	B2	8/2003	Schofield et al.	7,092,548	B2	8/2006	Laumeyer et al.
6,611,610	B1	8/2003	Stam et al.	7,116,246	B2	10/2006	Winter et al.
6,627,918	B2	9/2003	Getz et al.	7,123,168	B2	10/2006	Schofield
6,636,148	B2	10/2003	Higuchi	7,126,460	B2	10/2006	Yamada
6,636,258	B2	10/2003	Strumolo	7,126,525	B2	10/2006	Suzuki et al.
6,648,477	B2	11/2003	Hutzel et al.	7,149,613	B2	12/2006	Stam et al.
6,650,233	B2	11/2003	DeLine et al.	7,167,796	B2	1/2007	Taylor et al.
6,650,455	B2	11/2003	Miles	7,176,830	B2	2/2007	Horibe
6,672,731	B2	1/2004	Schnell et al.	7,188,963	B2	3/2007	Schofield et al.
6,674,562	B1	1/2004	Miles	7,196,305	B2	3/2007	Shaffer et al.
6,678,614	B2	1/2004	McCarthy et al.	7,199,747	B2	4/2007	Jenkins et al.
6,680,792	B2	1/2004	Miles	7,202,776	B2	4/2007	Breed
6,690,268	B2	2/2004	Schofield et al.	7,227,459	B2	6/2007	Bos et al.
6,696,978	B2	2/2004	Trajkovic et al.	7,227,611	B2	6/2007	Hull et al.
6,700,605	B1	3/2004	Toyoda et al.	7,311,406	B2	12/2007	Schofield et al.
6,703,925	B2	3/2004	Steffel	7,322,755	B2	1/2008	Neumann et al.
6,704,621	B1	3/2004	Stein et al.	7,325,934	B2	2/2008	Schofield et al.
6,710,908	B2	3/2004	Miles et al.	7,325,935	B2	2/2008	Schofield et al.
6,711,474	B1	3/2004	Treyz et al.	7,344,261	B2	3/2008	Schofield et al.
6,714,331	B2	3/2004	Lewis et al.	7,380,948	B2	6/2008	Schofield et al.
6,717,610	B1	4/2004	Bos et al.	7,388,182	B2	6/2008	Schofield et al.
6,727,807	B2	4/2004	Trajkovic et al.	7,400,266	B2	7/2008	Haug
6,735,506	B2	5/2004	Breed et al.	7,423,248	B2	9/2008	Schofield et al.
6,741,377	B2	5/2004	Miles	7,425,076	B2	9/2008	Schofield et al.
6,744,353	B2	6/2004	Sjönell	7,432,848	B2	10/2008	Munakata
6,757,109	B2	6/2004	Bos	7,436,038	B2	10/2008	Engelmann et al.
6,762,867	B2	7/2004	Lippert et al.	7,439,507	B2	10/2008	Deasy et al.
6,771,208	B2	8/2004	Lutter et al.	7,453,374	B2	11/2008	Koike et al.
6,772,057	B2	8/2004	Breed et al.	7,460,951	B2	12/2008	Altan et al.
6,794,119	B2	9/2004	Miles	7,480,149	B2	1/2009	DeWard et al.
6,795,014	B2	9/2004	Cheong	7,526,103	B2	4/2009	Schofield et al.
6,795,221	B1	9/2004	Urey	7,542,835	B2	6/2009	Takahama et al.
6,802,617	B2	10/2004	Schofield et al.	7,558,007	B2	7/2009	Katoh et al.
6,806,452	B2	10/2004	Bos et al.	7,570,198	B2	8/2009	Tokoro et al.
6,812,882	B2	11/2004	Ono	7,587,072	B2	9/2009	Russo et al.
6,816,084	B2	11/2004	Stein	7,613,568	B2	11/2009	Kawasaki
6,818,884	B2	11/2004	Koch et al.	7,619,508	B2	11/2009	Lynam et al.
6,822,563	B2	11/2004	Bos et al.	7,619,562	B2	11/2009	Stumbo et al.
6,823,241	B2	11/2004	Shirato et al.	7,633,383	B2	12/2009	Dunsmoir et al.
6,823,244	B2	11/2004	Breed	7,639,149	B2	12/2009	Katoh
6,824,281	B2	11/2004	Schofield et al.	7,671,806	B2	3/2010	Voigtlaender
6,828,903	B2	12/2004	Watanabe et al.	7,706,978	B2	4/2010	Schiffmann et al.
6,831,591	B2	12/2004	Horibe	7,720,580	B2	5/2010	Higgins-Luthman
6,838,980	B2	1/2005	Gloger et al.	7,728,272	B2	6/2010	Blaesing
6,841,767	B2	1/2005	Mindl et al.	7,765,065	B2	7/2010	Stiller
6,847,487	B2	1/2005	Burgner	7,777,669	B2	8/2010	Tokoro et al.
6,856,873	B2	2/2005	Breed et al.	7,811,011	B2	10/2010	Blaesing et al.
6,859,705	B2	2/2005	Rao et al.	7,828,478	B2	11/2010	Rege et al.
6,864,784	B1	3/2005	Loeb	7,855,353	B2	12/2010	Blaesing et al.
6,873,912	B2	3/2005	Shimomura	7,881,496	B2	2/2011	Camilleri et al.
				7,914,187	B2	3/2011	Higgins-Luthman et al.
				7,920,251	B2	4/2011	Chung
				7,978,122	B2	7/2011	Schmidlin
				8,013,780	B2	9/2011	Lynam

(56)

References Cited

U.S. PATENT DOCUMENTS

8,192,095 B2 6/2012 Kortan et al.
 8,217,830 B2 7/2012 Lynam
 8,294,608 B1 10/2012 Lynam
 8,614,640 B2 12/2013 Lynam
 9,140,789 B2 9/2015 Lynam
 9,244,165 B1 1/2016 Lynam
 9,335,411 B1 5/2016 Lynam
 9,507,021 B2 11/2016 Lynam
 2002/0015153 A1 2/2002 Downs
 2002/0021229 A1 2/2002 Stein
 2002/0044065 A1 4/2002 Quist et al.
 2002/0113873 A1 8/2002 Williams
 2002/0159270 A1 10/2002 Lynam et al.
 2003/0080878 A1 5/2003 Kirmuss
 2003/0112132 A1 6/2003 Trajkovic et al.
 2003/0137586 A1 7/2003 Lewellen
 2003/0138132 A1 7/2003 Stam
 2003/0201929 A1 10/2003 Lutter et al.
 2003/0222982 A1 12/2003 Hamdan et al.
 2003/0227777 A1 12/2003 Schofield
 2004/0012488 A1 1/2004 Schofield
 2004/0016870 A1 1/2004 Pawlicki et al.
 2004/0032321 A1 2/2004 McMahon et al.
 2004/0051634 A1 3/2004 Schofield et al.
 2004/0114381 A1 6/2004 Salmeen et al.
 2004/0128065 A1 7/2004 Taylor et al.
 2004/0200948 A1 10/2004 Bos et al.
 2004/0227663 A1 11/2004 Suzuki
 2004/0246167 A1 12/2004 Kumon
 2005/0046978 A1 3/2005 Schofield
 2005/0078389 A1 4/2005 Kulas et al.
 2005/0102070 A1 5/2005 Takahama
 2005/0104089 A1 5/2005 Engelmann
 2005/0134966 A1 6/2005 Burgner
 2005/0134983 A1 6/2005 Lynam
 2005/0146792 A1 7/2005 Schofield et al.
 2005/0169003 A1 8/2005 Lindahl et al.
 2005/0195488 A1 9/2005 McCabe et al.
 2005/0200700 A1 9/2005 Schofield et al.
 2005/0232469 A1 10/2005 Schofield et al.
 2005/0264891 A1 12/2005 Uken et al.
 2005/0270225 A1 12/2005 Tokoro
 2006/0018511 A1 1/2006 Stam et al.
 2006/0018512 A1 1/2006 Stam et al.
 2006/0028731 A1 2/2006 Schofield et al.

2006/0050018 A1 3/2006 Hutzel et al.
 2006/0067378 A1 3/2006 Rege et al.
 2006/0091654 A1 5/2006 De Mersseman et al.
 2006/0091813 A1 5/2006 Stam et al.
 2006/0103727 A1 5/2006 Tseng
 2006/0157639 A1 7/2006 Shaffer
 2006/0164230 A1 7/2006 DeWind et al.
 2006/0250501 A1 11/2006 Wildmann et al.
 2007/0023613 A1 2/2007 Schofield et al.
 2007/0088488 A1 4/2007 Reeves et al.
 2007/0104476 A1 5/2007 Yasutomi et al.
 2007/0109406 A1 5/2007 Schofield et al.
 2007/0109651 A1 5/2007 Schofield et al.
 2007/0109652 A1 5/2007 Schofield et al.
 2007/0109653 A1 5/2007 Schofield et al.
 2007/0109654 A1 5/2007 Schofield et al.
 2007/0120657 A1 5/2007 Schofield et al.
 2007/0152152 A1 7/2007 Deasy
 2007/0176080 A1 8/2007 Schofield et al.
 2008/0117097 A1 5/2008 Walter et al.
 2008/0180529 A1 7/2008 Taylor et al.
 2009/0113509 A1 4/2009 Tseng et al.
 2010/0001897 A1 1/2010 Lynam
 2010/0045797 A1 2/2010 Schofield et al.
 2011/0037640 A1 2/2011 Schmidlin

FOREIGN PATENT DOCUMENTS

JP H08276787 10/1996
 JP H10147178 6/1998
 JP H1178737 3/1999
 JP 2001158284 6/2001
 JP 2001233139 8/2001
 JP 2003044995 2/2003
 JP 2003169233 6/2003
 JP 2004082829 3/2004
 WO WO2003053743 7/2003
 WO WO2006035510 4/2006

OTHER PUBLICATIONS

Bombini et al., "Radar-vision fusion for vehicle detection" Dipartimento di Ingegneria dell'Informazione Universita di Parma Parma I-43100 Italy Mar. 14, 2006.
 PCT International Search Report of PCT/US2008/051833 dated Oct. 7, 2008.
 European Examination Report for EP Application No. 08780377.1 dated Aug. 8, 2012.

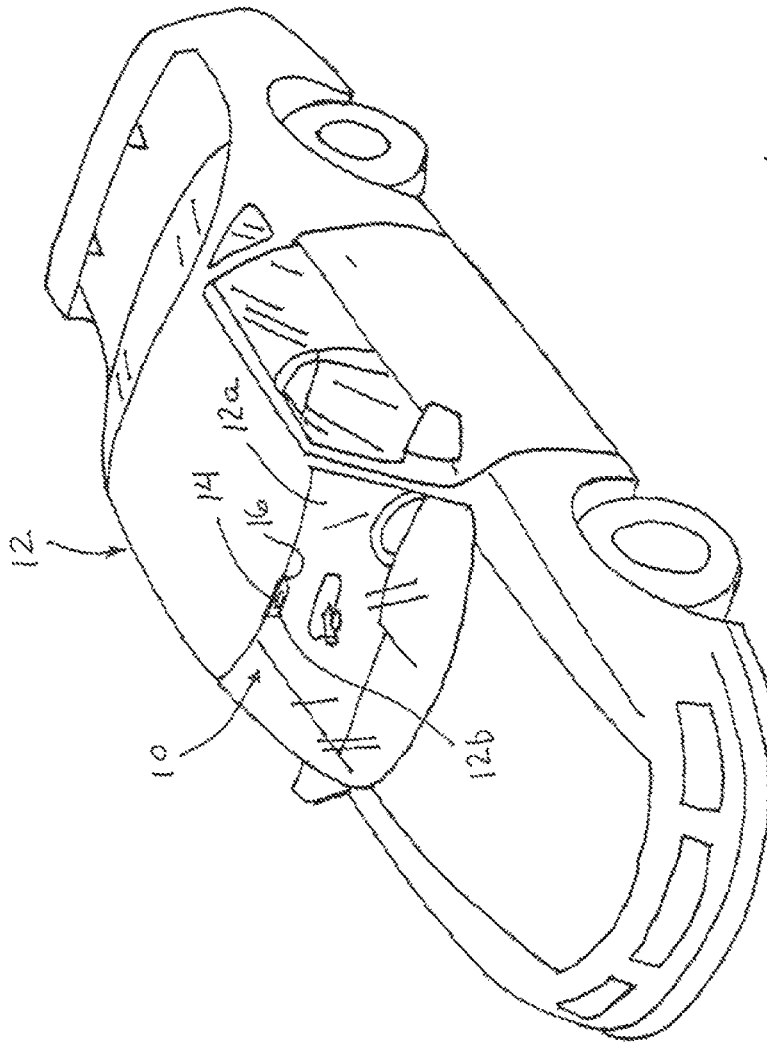

FIG. 1

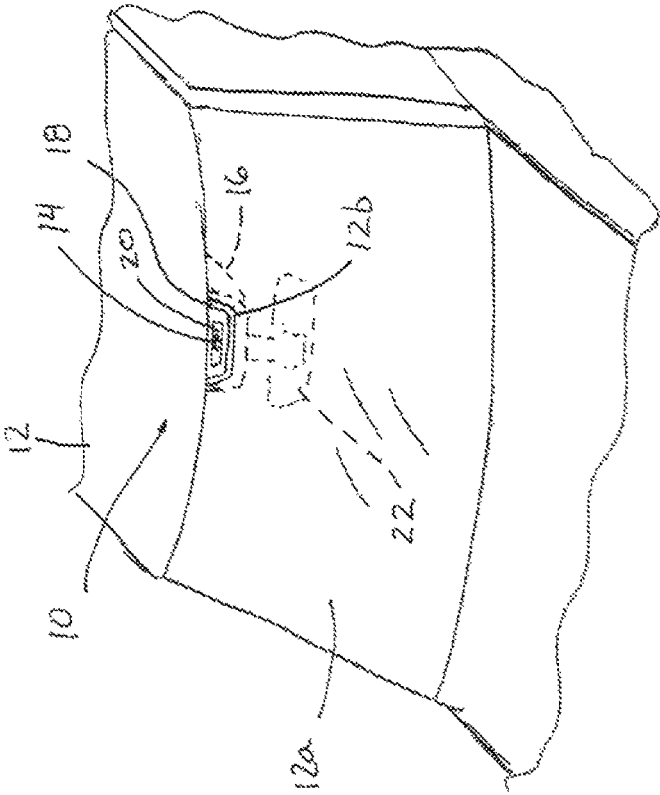

FIG. 2

FORWARD FACING SENSING SYSTEM FOR VEHICLE**CROSS REFERENCE TO RELATED APPLICATIONS**

This application is a continuation of U.S. patent application Ser. No. 15/149,338, filed May 9, 2016, now U.S. Pat. No. 9,507,021, which is a continuation of U.S. patent application Ser. No. 15/005,092, filed Jan. 25, 2016, now U.S. Pat. No. 9,335,411, which is a continuation of U.S. patent application Ser. No. 14/859,683, filed Sep. 21, 2015, now U.S. Pat. No. 9,244,165, which is a continuation of U.S. patent application Ser. No. 14/107,624, filed Dec. 16, 2013, now U.S. Pat. No. 9,140,789, which is a divisional of U.S. patent application Ser. No. 13/656,975, filed Oct. 22, 2012, now U.S. Pat. No. 8,614,640, which is a continuation of U.S. patent application Ser. No. 13/540,856, filed Jul. 3, 2012, now U.S. Pat. No. 8,294,608, which is a continuation of U.S. patent application Ser. No. 13/192,525, filed Jul. 28, 2011, now U.S. Pat. No. 8,217,830, which is a continuation of U.S. patent application Ser. No. 12/524,446, filed Jul. 24, 2009, now U.S. Pat. No. 8,013,780, which is a 371 application of PCT Application No. PCT/US2008/051833, filed Jan. 24, 2008, which claims the benefit of U.S. provisional application Ser. No. 60/886,568, filed Jan. 25, 2007, which are incorporated herein by reference for all purposes.

FIELD OF THE INVENTION

The present invention generally relates to forward facing sensing systems and, more particularly, to forward facing sensing systems utilizing a radar sensor device.

BACKGROUND OF THE INVENTION

It is known to provide a radar (radio detection and ranging) system (such as a 77 GHz radar or other suitable frequency radar) on a vehicle for sensing the area forward of a vehicle, such as for an adaptive cruise control (ACC) system or an ACC stop and go system or the like. It is also known to provide a lidar (laser imaging detection and ranging) system for sensing the area forward of a vehicle for similar applications. Typically, the radar system is preferred for such vehicle applications because of its ability to detect better than the lidar system in fog or other inclement weather conditions.

Typically, such radar sensor devices are often located at the front grille of the vehicle and thus may be intrusive to the underhood packaging of the vehicle and the exterior styling of the vehicle. Although it is known to provide a lidar sensing device or system at the windshield for scanning/detecting through the windshield, radar systems are typically not suitable for such applications, since they typically are not suitable for viewing through glass, such as through the vehicle windshield (because the glass windshield may substantially attenuate the radar performance or ability to detect objects forward of the vehicle). It is also known to augment such a radar or lidar system with a forward facing camera or image sensor.

SUMMARY OF THE INVENTION

The present invention provides a forward facing sensing system for detecting objects forward of the vehicle (such as for use with or in conjunction with an adaptive cruise control system or other object detection system or the like), with a

radar sensor device being located behind, and transmitting through [typically, transmitting at at least about 20 GHz frequency (such as 24 GHz) and more preferably at least about 60 GHz frequency (such as 60 GHz or 77 GHz or 79 GHz or thereabouts)], a radar transmitting portion established at the upper windshield area of the vehicle. The radar sensor device is positioned at a recess or pocket or opening formed at and along the upper edge of the windshield so as to have a forward transmitting and receiving direction for radar electromagnetic waves that is not through the glass panels of the windshield. The vehicle or sensing system preferably includes a sealing or cover element, such as a plastic cover element at the sensing device to seal/environmentally protect the radar sensor device within the cabin of the vehicle while allowing for transmission of and receipt of radar frequency electromagnetic radiation waves to and from the exterior of the vehicle.

According to an aspect of the present invention, a forward facing sensing system or radar sensing system for a vehicle includes a radar sensor device disposed at a pocket or recess or opening established at an upper edge of the vehicle windshield and having a forward transmitting and receiving direction that is not through the windshield. A cover panel is disposed at the radar sensor device and is substantially sealed at the vehicle windshield at or near the pocket at the upper edge of the vehicle windshield. The cover panel comprises a material that is substantially transmissive to radar frequency electromagnetic radiation waves. The radar sensor device transmits and receives radar frequency electromagnetic radiation waves that transmit through the cover panel. The system includes a control that is responsive to an output of the radar sensor device.

According to another aspect of the present invention, a forward facing sensing system for a vehicle includes a radar sensor device operable to detect an object ahead of the vehicle, a forward facing image sensor having a forward field of view, and a control responsive to an output of the radar sensor device and responsive to an output of the forward facing image sensor. The control is operable to control sensing by the radar sensor device and the control is operable to control a focused or enhanced interrogation of a detected object (or area at which a detected object is detected) in response to a detection of an object forward of the vehicle by the radar sensor device. The control may be operable to at least one of (a) control enhanced interrogation of a detected object by the radar sensor device in response to the forward facing image sensor detecting an object (such as by enhancing the interrogation via a beam aiming or beam selection technique, such as by digital beam forming in a phased array antenna system or such as by digital beam steering or the like), and (b) control enhanced interrogation of a detected object by the forward facing image sensor in response to the radar sensor device detecting an object (such as by enhancing the interrogation via enhanced or intensified algorithmic processing of a portion of the image plane of the image sensor that is spatially related to the location of the detected object in the forward field of view of the image sensor). The control thus may be responsive to the forward facing image sensor to guide or control the focused interrogation of the detected object by the radar sensor device, or the control may be responsive to the radar sensor device to guide or control the focused or enhanced interrogation of the detected object by the forward facing image sensor (such as via directing or controlling the image sensor and/or its field of view or zoom function or via image processing of the captured image data, such as by providing enhanced processing of the area at which the object is detected).

Optionally, and desirably, the forward facing image sensor and the radar sensor device may be commonly established on a semiconductor substrate. Optionally, the semiconductor substrate may comprise one of (i) a germanium substrate, (ii) a gallium arsenide substrate, and (iii) a silicon germanium substrate.

These and other objects, advantages, purposes and features of the present invention will become apparent upon review of the following specification in conjunction with the drawings.

BRIEF DESCRIPTION OF THE DRAWINGS

FIG. 1 is a perspective view of a vehicle incorporating a forward facing radar sensing system in accordance with the present invention; and

FIG. 2 is a perspective view of a windshield and radar sensing system of the present invention.

DESCRIPTION OF THE PREFERRED EMBODIMENTS

Referring now to the drawings and the illustrative embodiments depicted therein, a sensing system or forward facing sensing system or radar sensing system **10** for a vehicle **12** includes a radar sensor device **14** at an upper region of the vehicle windshield **12a** and with a forward transmitting and sensing direction forward of the vehicle and in the forward direction of travel of the vehicle (FIG. 1). The windshield glass **12a** may be formed with a cutout or pocket **12b** at the upper edge. The pocket may be cut from the glass (so as to provide a cut opening at the upper edge of the glass windshield) or the glass may be formed with an inward bulge or pocket that provides an opening for the sensing device. The radar sensor device **14** thus may be disposed at the pocket **12b** and may have a clear or unobstructed view or sensing direction forward of the vehicle that does not pass through glass (and whereby the glass windshield will not attenuate the performance of the radar sensor device). Because the upper region of the vehicle windshield is typically not used, the radar sensor device **14** may be disposed thereat without being intrusive of other systems or elements and without adversely affecting the vehicle design and/or layout. The sensing system **10** is operable to detect objects or vehicles or the like in front of the vehicle as the vehicle is traveling along a road, such as in conjunction with an adaptive cruise control system or the like. Although shown and described as being a forward facing sensing system, aspects of the present invention may be suitable for other sensing systems, such as a rearward facing sensing system or the like.

Radar sensor device **14** thus may be disposed within a windshield electronics module **16** or accessory module or overhead console of the vehicle, and within the vehicle cabin, without experiencing the adverse performance caused by the attenuation of radio or radar frequency electromagnetic radiation wave transmission through the windshield glass. Optionally, the vehicle sheet metal may be adapted to receive and/or support the radar sensor device at the upper edge of the windshield, or to accommodate the radar sensor device as disposed in and/or supported by the windshield electronics module or the like.

In order to seal the upper edge of the windshield at the pocket **12b**, a cover element or plate **18** may be provided that substantially or entirely spans the opening at the pocket and that is sealed at the glass windshield and vehicle around the perimeter of the pocket, so as to limit or substantially

preclude water intrusion or the like into the vehicle at the radar sensor device. The cover element **18** preferably comprises a plastic or polymeric or polycarbonate material that is transmissive to radar waves so as to limit or substantially preclude an adverse effect on the performance of the radar sensor device and system. Optionally, and desirably, the cover element may be colored to match or substantially match the shade band along the upper region of the windshield or to match or substantially match the windshield electronics module or other interior or exterior component of the vehicle. Because the radar sensor device does not require a transparent cover, the cover element may be opaque or substantially opaque and/or may function to substantially camouflage or render covert the sensor device and/or the windshield electronics module or the like.

The radar sensor device may utilize known transmitting and receiving technology and may utilize a sweeping beam or a phased array or the like for scanning or sensing or interrogating the area in front of the vehicle. Optionally, the forward facing radar sensing system may include or may be associated with a forward facing camera or imaging sensor **20** (which may be disposed at or in the windshield electronics module or accessory module or overhead console or at another accessory module or windshield electronics module or at the interior rearview mirror assembly **22** or the like), which has a forward field of view in the forward direction of travel of the vehicle. The sensing system may function to perform a "sweep" of the area in front of the vehicle and if an object or the like is detected (e.g., the radar sensing system detects a "blip"), the radar sensor device and system may hone in on or focus on or further interrogate the region where the object is detected and may perform a more focused or enhanced interrogation of the area at which the object was detected to determine if the object is an object of interest. Optionally, for example, the system may control enhanced interrogation of a detected object by the radar sensor device (such as a beam aiming or beam selection technique, such as by digital beam forming in a phased array antenna system or such as by digital beam steering). Such enhanced interrogation by the radar sensor device may be in response to the forward facing image sensor detecting an object in its forward field of view.

Optionally, and desirably, the forward facing camera may guide or initiate or control the more focused interrogation of the suspected object of interest (such as further or enhanced interrogation by the camera and imaging system) in response to the initial detection by the radar sensing system. For example, the radar sensing system may initially detect an object and the forward facing camera may be directed toward the detected object or otherwise controlled or processed to further interrogate the detected object (or area at which the object is detected) via the camera and image processing, or, alternately, the forward facing camera may initially detect an object and the system may select or aim a radar beam in a direction of a detected object. The enhanced interrogation of the object area by the forward facing camera may be accomplished via control of the camera's field of view or degree of zoom [for example, the camera may zoom into the area (via adjustment of a lens of the camera to enlarge an area of the field of view for enhanced processing) at which the object is detected] or via control of the image processing techniques. For example, the image processor may provide enhanced processing of the captured image data at the area or zone at which the object is detected, such as by enhanced or intensified algorithmic processing of a portion of the image plane of the image sensor that is spatially related to the location of the detected object in the

forward field of view of the image sensor, such as by enhanced processing of pixel outputs of pixels within a zone or sub-array of a pixelated imaging array sensor, such as by utilizing aspects of the imaging systems described in U.S. Pat. Nos. 7,123,168; 7,038,577; 7,004,606; 6,690,268; 6,396,397; 5,550,677; 5,670,935; 5,796,094; 5,877,897 and 6,498,620, and/or U.S. patent application Ser. No. 11/239,980, filed Sep. 30, 2005, now U.S. Pat. No. 7,881,496; and/or Ser. No. 11/315,675, filed Dec. 22, 2005, now U.S. Pat. No. 7,720,580, which are all hereby incorporated herein by reference in their entireties.

Thus, the sensing system of the present invention provides for cooperation or collaboration between the radar sensor device and the forward facing camera or image sensor in a way that benefits or enhances the sensing capabilities of the forward facing sensing system. The sensing system may thus operate with reduced processing until an object is initially detected, and then may provide further processing to determine if the object is an object of interest to the forward facing sensing system.

Optionally, and desirably, the radar sensor device and forward facing camera may be commonly established on a semiconductor substrate, such as a substrate comprising a germanium substrate, a gallium arsenide substrate or a silicon germanium substrate or the like. The substrate may include or may incorporate at least some of the control circuitry for the radar sensor device and camera and/or may include or incorporate common circuitry for the radar sensor device and camera.

Because the radar sensor device and camera may be disposed on a common substrate and/or may be disposed within a windshield electronics module or the like, the forward facing sensing system may be removably installed at the vehicle and may be removed therefrom, such as for service or replacement. Thus, the sensing system (including the radar sensor device and camera) may comprise a self-contained unit or system that is disposed at the upper region of the windshield. Optionally, the radar sensor device and/or camera may be disposed within a windshield electronics module or the like, such as by utilizing aspects of the modules described in U.S. patent application Ser. No. 10/958,087, filed Oct. 4, 2004, now U.S. Pat. No. 7,188,963; and/or Ser. No. 11/201,661, filed Aug. 11, 2005, now U.S. Pat. No. 7,480,149, and/or U.S. Pat. Nos. 7,004,593; 6,824,281; 6,690,268; 6,250,148; 6,341,523; 6,593,565; 6,428,172; 6,501,387; 6,329,925 and 6,326,613, and/or in PCT Application No. PCT/US03/40611, filed Dec. 19, 2003 and published Jul. 15, 2004 as International Publication No. WO 2004/058540, and/or Ireland pat. applications, Ser. No. S2004/0614, filed Sep. 15, 2004; Ser. No. S2004/0838, filed Dec. 14, 2004; and Ser. No. S2004/0840, filed Dec. 15, 2004, which are all hereby incorporated herein by reference in their entireties.

Optionally, the mirror assembly and/or windshield electronics module may include or incorporate a display, such as a static display, such as a static video display screen (such as a display utilizing aspects of the displays described in U.S. Pat. Nos. 5,530,240 and/or 6,329,925, which are hereby incorporated herein by reference in their entireties, or a display-on-demand or transmissive type display or other display utilizing aspects of the displays described in U.S. Pat. Nos. 6,690,268; 5,668,663 and/or 5,724,187, and/or U.S. patent application Ser. No. 10/054,633, filed Jan. 22, 2002, now U.S. Pat. No. 7,195,381; Ser. No. 11/021,065, filed Dec. 23, 2004, now U.S. Pat. No. 7,255,451; Ser. No. 10/528,269, filed Mar. 17, 2005, now U.S. Pat. No. 7,274,501; Ser. No. 10/533,762, filed May 4, 2005, now U.S. Pat.

No. 7,184,190; Ser. No. 10/538,724, filed Jun. 13, 2005 and published on Mar. 9, 2006 as U.S. Publication No. US 2006/0050018; Ser. No. 11/226,628, filed Sep. 14, 2005 and published Mar. 23, 2006 as U.S. Publication No. US 2006/0061008; Ser. No. 10/993,302, filed Nov. 19, 2004, now U.S. Pat. No. 7,338,177; and/or Ser. No. 11/284,543, filed Nov. 22, 2005, now U.S. Pat. No. 7,370,983, and/or PCT Patent Application No. PCT/US2006/018567, filed May 15, 2006 and published Nov. 23, 2006 as International Publication No. WO 2006/124682; and/or PCT Application No. PCT/US2006/042718, filed Oct. 31, 2006, published May 10, 2007 as International Publication No. WO 07/053710; and U.S. provisional applications, Ser. No. 60/836,219, filed Aug. 8, 2006; Ser. No. 60/759,992, filed Jan. 18, 2006; and Ser. No. 60/732,245, filed Nov. 1, 2005, and/or PCT Application No. PCT/US03/40611, filed Dec. 19, 2003, and published Jul. 15, 2004 as International Publication No. WO 2004/058540, which are all hereby incorporated herein by reference in their entireties). Alternately, the display screen may comprise a display (such as a backlit LCD video display) that is movable to extend from the mirror casing when activated, such as a slide-out display of the types described in U.S. patent application Ser. No. 10/538,724, filed Jun. 13, 2005 and published on Mar. 9, 2006 as U.S. Publication No. US 2006/0050018; and/or Ser. No. 11/284,543, filed Nov. 22, 2005, now U.S. Pat. No. 7,370,983, and/or PCT Patent Application No. PCT/US2006/018567, filed May 15, 2006 and published Nov. 23, 2006 as International Publication No. WO 2006/124682; and/or PCT Application No. PCT/US2006/042718, filed Oct. 31, 2006, and published May 10, 2007 as International Publication No. WO 07/053710; and U.S. provisional applications, Ser. No. 60/836,219, filed Aug. 8, 2006; Ser. No. 60/759,992, filed Jan. 18, 2006; and Ser. No. 60/732,245, filed Nov. 1, 2005, which are all hereby incorporated herein by reference in their entireties. Optionally, and preferably, the display is episodically extended and/or actuated, such as to display driving instructions to the driver as the vehicle approaches a waypoint or turn along the selected route, and then retracted after the vehicle has passed the waypoint and continues along the selected route.

Optionally, the display on the video screen may be operable to display an alert to the driver of a potential hazardous condition detected ahead of or in the forward path of the vehicle. For example, an output of a forward-viewing active night vision system incorporating an imaging sensor or camera device and near-IR floodlighting (such as those described in U.S. Pat. No. 5,877,897 and U.S. patent application Ser. No. 11/651,726, filed Jan. 10, 2007, now U.S. Pat. No. 7,311,406, which are hereby incorporated herein by reference in their entireties), or an output of another suitable forward facing sensor or system such as a passive far-IR thermal imaging night vision sensor/camera, may be processed by an image processor, such as, for example, an EyeQ™ image processing chip available from Mobileye Vision Technologies Ltd. of Jerusalem, Israel. Such image processors include object detection software (such as the types described in U.S. Pat. No. 7,038,577; and/or Ser. No. 11/315,675, filed Dec. 22, 2005, now U.S. Pat. No. 7,720,580, which are hereby incorporated herein by reference in their entireties), and they analyze image data to detect objects. The image processor or control may determine if a potentially hazardous condition (such as an object or vehicle or person or deer or the like) may exist in the vehicle path and may provide an alert signal (such as by actuation of a visual indicator or an audible indicator or by an enhancement/overlay on a video display screen that is showing a

video image to the driver of what the night vision sensor/camera is seeing) to prompt/alert the driver of a potential hazard (such as a deer or a pedestrian or a fallen rock or the like) as needed or appropriate. The display thus may provide an episodal alert so that the driver's attention is drawn to the display alert only when there is a potential hazard detected. Such a system avoids the driver from having to look forward out the windshield while often looking to or watching a monitor running a video of the camera's output, which is not particularly consumer-friendly and simply loads the driver with yet another task.

Optionally, the mirror reflective element of the mirror assembly may comprise a prismatic mirror reflector or an electrically variable reflectance mirror reflector, such as an electro-optic reflective element assembly or cell, such as an electrochromic reflective element assembly or cell. For example, the rearview mirror assembly may comprise an electro-optic or electrochromic reflective element or cell, such as an electrochromic mirror assembly and electrochromic reflective element utilizing principles disclosed in commonly assigned U.S. Pat. Nos. 6,690,268; 5,140,455; 5,151,816; 6,178,034; 6,154,306; 6,002,544; 5,567,360; 5,525,264; 5,610,756; 5,406,414; 5,253,109; 5,076,673; 5,073,012; 5,117,346; 5,724,187; 5,668,663; 5,910,854; 5,142,407; 4,824,221; 5,818,636; 6,166,847; 6,111,685; 6,392,783; 6,710,906; 6,798,556; 6,554,843; 6,420,036; 5,142,406; 5,442,478 and/or 4,712,879, and/or U.S. patent application Ser. No. 10/054,633, filed Jan. 22, 2002, now U.S. Pat. No. 7,195,381; Ser. No. 11/021,065, filed Dec. 23, 2004, now U.S. Pat. No. 7,255,451; Ser. No. 10/528,269, filed Mar. 17, 2005, now U.S. Pat. No. 7,274,501; Ser. No. 10/533,762, filed May 4, 2005, now U.S. Pat. No. 7,184,190; Ser. No. 10/538,724, filed Jun. 13, 2005, and published on Mar. 9, 2006 as U.S. Publication No. US 2006/0050018; Ser. No. 11/226,628, filed Sep. 14, 2005 and published Mar. 23, 2006 as U.S. Publication No. US 2006/0061008; Ser. No. 10/993,302, filed Nov. 19, 2004, now U.S. Pat. No. 7,338,177; and/or Ser. No. 11/284,543, filed Nov. 22, 2005, now U.S. Pat. No. 7,370,983, and/or International Pat. Publication Nos. WO 2004/098953, published Nov. 18, 2004; WO 2004/042457, published May 21, 2004; WO 2003/084780, published Oct. 16, 2003; and/or WO 2004/026633, published Apr. 1, 2004, which are all hereby incorporated herein by reference in their entireties, and/or such as disclosed in the following publications: N. R. Lynam, "Electrochromic Automotive Day/Night Mirrors", SAE Technical Paper Series 870636 (1987); N. R. Lynam, "Smart Windows for Automobiles", SAE Technical Paper Series 900419 (1990); N. R. Lynam and A. Agrawal, "Automotive Applications of Chromogenic Materials", Large Area Chromogenics: Materials and Devices for Transmittance Control, C. M. Lampert and C. G. Granquist, EDS., Optical Engineering Press, Wash. (1990), which are hereby incorporated herein by reference in their entireties.

Optionally, and preferably, the mirror reflective element may comprise a frameless reflective element, such as by utilizing aspects of the reflective elements described in PCT Application No. PCT/US2006/018567, filed May 15, 2006 and published Nov. 23, 2006 as International Publication No. WO 2006/124682; PCT Application No. PCT/US2004/015424, filed May 18, 2004 and published on Dec. 2, 2004, as International Publication No. WO 2004/103772; and/or U.S. patent application Ser. No. 11/140,396, filed May 27, 2005, now U.S. Pat. No. 7,360,932; Ser. No. 11/226,628, filed Sep. 14, 2005, and published Mar. 23, 2006 as U.S. Publication No. US 2006/0061008; Ser. No. 11/021,065, filed Dec. 23, 2004, now U.S. Pat. No. 7,255,451; Ser. No.

10/528,269, filed Mar. 17, 2005, now U.S. Pat. No. 7,274,501; Ser. No. 10/533,762, filed May 4, 2005, now U.S. Pat. No. 7,184,190; and/or Ser. No. 10/538,724, filed Jun. 13, 2005, and published on Mar. 9, 2006 as U.S. Publication No. US 2006/0050018, which are hereby incorporated herein by reference in their entireties. Optionally, the reflective element may include a metallic perimeter band around the perimeter of the reflective element, such as by utilizing aspects of the reflective elements described in PCT Application No. PCT/US2006/018567, filed May 15, 2006 and published Nov. 23, 2006 as International Publication No. WO 2006/124682; PCT Application No. PCT/US03/29776, filed Sep. 19, 2003 and published Apr. 1, 2004 as International Publication No. WO 2004/026633; and/or PCT Application No. PCT/US03/35381, filed Nov. 5, 2003 and published May 21, 2004 as International Publication No. WO 2004/042457; and/or U.S. patent application Ser. No. 11/021,065, filed Dec. 23, 2004, now U.S. Pat. No. 7,255,451; and/or Ser. No. 11/226,628, filed Sep. 14, 2005 and published Mar. 23, 2006 as U.S. Publication No. US 2006/0061008, which is hereby incorporated herein by reference in their entireties. The frameless reflective element thus is aesthetically pleasing to a person viewing the mirror assembly, since the reflective element (as recessed or partially recessed) in the opening of the bezel portion of the mirror casing) does not include a separate frame or bezel portion around its perimeter edge. The metallic perimeter band may be selected to have a desired color or tint to match or contrast a color scheme or the like of the vehicle, such as described in PCT Application No. PCT/US2006/018567, filed May 15, 2006 and published Nov. 23, 2006 as International Publication No. WO 2006/124682; and/or PCT Application No. PCT/US2004/015424, filed May 18, 2004 and published Dec. 2, 2004 as International Publication No. WO 2004/103772, which are hereby incorporated herein by reference in their entireties.

Optionally, use of an elemental semiconductor mirror, such as a silicon metal mirror, such as disclosed in U.S. Pat. Nos. 6,286,965; 6,196,688; 5,535,056; 5,751,489 and 6,065,840, and/or in U.S. patent application Ser. No. 10/993,302, filed Nov. 19, 2004, now U.S. Pat. No. 7,338,177, which are all hereby incorporated herein by reference in their entireties, can be advantageous because such elemental semiconductor mirrors (such as can be formed by depositing a thin film of silicon) can be greater than 50 percent reflecting in the photopic (SAE J964a measured), while being also substantially transmitting of light (up to 20 percent or even more). Such silicon mirrors also have the advantage of being able to be deposited onto a flat glass substrate and to be bent into a curved (such as a convex or aspheric) curvature, which is also advantageous since many passenger-side exterior rearview mirrors are bent or curved.

Optionally, the mirror assembly may comprise a prismatic mirror assembly, such as a prismatic mirror assembly utilizing aspects described in U.S. Pat. Nos. 6,318,870; 6,598,980; 5,327,288; 4,948,242; 4,826,289; 4,436,371 and 4,435,042, and PCT Application No. PCT/US04/015424, filed May 18, 2004 and published Dec. 2, 2004 as International Publication No. WO 2004/103772; and U.S. patent application Ser. No. 10/933,842, filed Sep. 3, 2004, now U.S. Pat. No. 7,249,860, which are hereby incorporated herein by reference in their entireties. Optionally, the prismatic reflective element may comprise a conventional prismatic reflective element or prism, or may comprise a prismatic reflective element of the types described in PCT Application No. PCT/US03/29776, filed Sep. 19, 2003 and published Apr. 1, 2004 as International Publication No. WO 2004/026633;

and/or U.S. patent application Ser. No. 10/709,434, filed May 5, 2004, now U.S. Pat. No. 7,420,756; Ser. No. 10/933,842, filed Sep. 3, 2004, now U.S. Pat. No. 7,249,860; Ser. No. 11/021,065, filed Dec. 23, 2004, now U.S. Pat. No. 7,255,451; Ser. No. 10/528,269, filed Mar. 17, 2005, now U.S. Pat. No. 7,274,501; and/or Ser. No. 10/993,302, filed Nov. 19, 2004, now U.S. Pat. No. 7,338,177, and/or PCT Application No. PCT/US2004/015424, filed May 18, 2004 and published Dec. 2, 2004 as International Publication No. WO 2004/103772, which are all hereby incorporated herein by reference in their entireties, without affecting the scope of the present invention.

Optionally, the reflective element may comprise a bent, wide-angle mirror reflector rather than a flat mirror reflector. If a bent, wide-angle mirror reflector is used, it is preferable that the mirror reflector comprise a glass substrate coated with a bendable reflector coating (such as of silicon as described in U.S. Pat. Nos. 6,065,840; 5,959,792; 5,535,056 and 5,751,489, which are hereby incorporated by reference herein in their entireties.

Optionally, the mirror casing and/or windshield electronics module may be suitable for supporting larger or heavier components or circuitry that otherwise may not have been suitable for mounting or locating at or in a mirror casing. For example, the mirror casing or module may house or support a battery or power pack for various electronic features or components, and/or may support a docking station for docking and/or holding a cellular telephone or hand-held personal data device or the like, such as by utilizing aspects of the systems described in U.S. Pat. No. 6,824,281, and/or PCT Application No. PCT/US03/40611, filed Dec. 19, 2003 and published Jul. 15, 2004 as International Publication No. WO 2004/058540, and/or U.S. patent application Ser. No. 10/510,813, filed Aug. 23, 2002, now U.S. Pat. No. 7,306,276, and/or U.S. patent application Ser. No. 11/842,328, filed Aug. 21, 2007, now U.S. Pat. No. 7,722,199, and Ser. No. 11/861,904, filed Sep. 26, 2007, now U.S. Pat. No. 7,937,667, and/or U.S. provisional application, Ser. No. 60/839,446, filed Aug. 23, 2006; Ser. No. 60/879,619, filed Jan. 10, 2007; Ser. No. Ser. No. 60/850,700, filed Oct. 10, 2006; and/or Ser. No. 60/847,502, filed Sep. 27, 2006, which are hereby incorporated herein by reference in their entireties.

Optionally, the mirror assembly and/or windshield electronics module may include or incorporate a navigation device that may include navigational circuitry and a GPS antenna to determine the geographical location of the vehicle and to provide routes to targeted or selected destinations, such as by utilizing aspects of known navigational devices and/or the devices of the types described in U.S. Pat. Nos. 4,862,594; 4,937,945; 5,131,154; 5,255,442; 5,632,092; 5,798,688; 5,971,552; 5,924,212; 6,243,003; 6,278,377; 6,420,975; 6,946,978; 6,477,464; 6,678,614 and/or 7,004,593, and/or U.S. patent application Ser. No. 10/645,762, filed Aug. 20, 2003, now U.S. Pat. No. 7,167,796; Ser. No. 10/529,715, filed Mar. 30, 2005, now U.S. Pat. No. 7,657,052; Ser. No. 10/538,724, filed Jun. 13, 2005 and published Mar. 9, 2006 as U.S. Publication No. 2006/0050018; Ser. No. 11/861,904, filed Sep. 26, 2007, now U.S. Pat. No. 7,937,667; and/or Ser. No. 10/964,512, filed Oct. 13, 2004, now U.S. Pat. No. 7,308,341, and/or U.S. provisional applications, Ser. No. 60/879,619, filed Jan. 10, 2007; Ser. No. Ser. No. 60/850,700, filed Oct. 10, 2006; and/or Ser. No. 60/847,502, filed Sep. 27, 2006, which are all hereby incorporated herein by reference in their entireties. Optionally, the mirror or navigation device may include a micro-

phone, whereby the mirror or navigation device may provide voice activated control of the navigation device.

Optionally, for example, the mounting structure and/or mirror casing and/or windshield electronics module may support compass sensors, such as compass sensors of the types described in may utilize aspects of the compass systems described in U.S. patent application Ser. No. 11/305,637, filed Dec. 16, 2005, now U.S. Pat. No. 7,329,013; Ser. No. 10/352,691, filed Jan. 28, 2003, now U.S. Pat. No. 6,922,902; Ser. No. 11/284,543, filed Nov. 22, 2005, now U.S. Pat. No. 7,370,983; Ser. No. 11/226,628, filed Sep. 14, 2005, and published on Mar. 23, 2006 as U.S. Publication No. 2006/0061008; and/or Ser. No. 10/933,842, filed Sep. 3, 2004, now U.S. Pat. No. 7,249,860; and/or U.S. Pat. Nos. 7,004,593; 4,546,551; 5,699,044; 4,953,305; 5,576,687; 5,632,092; 5,677,851; 5,708,410; 5,737,226; 5,802,727; 5,878,370; 6,087,953; 6,173,508; 6,222,460; 6,513,252 and 6,642,851, and/or PCT Application No. PCT/US2004/015424, filed May 18, 2004 and published Dec. 2, 2004 as International Publication No. WO 2004/103772, and/or European patent application, published Oct. 11, 2000 under Publication No. EP 0 1043566, which are all hereby incorporated herein by reference in their entireties. The compass circuitry may include the compass sensor, such as a magneto-responsive sensor, such as a magneto-resistive sensor, such as the types disclosed in U.S. Pat. Nos. 5,255,442; 5,632,092; 5,802,727; 6,173,501; 6,427,349 and 6,513,252 (which are hereby incorporated herein by reference in their entireties), a magneto-capacitive sensor, a Hall-effect sensor, such as the types described in U.S. Pat. Nos. 6,278,271; 5,942,895 and 6,184,679 (which are hereby incorporated herein by reference in their entireties), a magneto-inductive sensor, such as described in U.S. Pat. No. 5,878,370 (which is hereby incorporated herein by reference in its entirety), a magneto-impedance sensor, such as the types described in PCT Publication No. WO 2004/076971, published Sep. 10, 2004 (which is hereby incorporated herein by reference in its entirety), or a flux-gate sensor or the like, and/or may comprise a compass chip, such as described in U.S. patent application Ser. No. 11/226,628, filed Sep. 14, 2005, and published on Mar. 23, 2006 as U.S. Publication No. 2006/0061008; and/or Ser. No. 11/284,543, filed Nov. 22, 2005, now U.S. Pat. No. 7,370,983, which are hereby incorporated herein by reference in their entireties. By positioning the compass sensors at a fixed location, further processing and calibration of the sensors to accommodate adjustment or movement of the sensors is not necessary.

Optionally, the mounting structure and/or mirror casing and/or windshield electronics module may support one or more imaging sensors or cameras, and may fixedly support them with the cameras set with a desired or appropriate forward and/or rearward field of view. For example, the camera may be operable in conjunction with a forward facing imaging system, such as a rain sensing system, such as described in U.S. Pat. Nos. 6,968,736; 6,806,452; 6,516,664; 6,353,392; 6,313,454; 6,250,148; 6,341,523 and 6,824,281, and in U.S. patent application Ser. No. 10/958,087, filed Oct. 4, 2004, now U.S. Pat. No. 7,188,963; and/or Ser. No. 11/201,661, filed Aug. 11, 2005, now U.S. Pat. No. 7,480,149, which are all hereby incorporated herein by reference in their entireties. The mounting structure and/or mirror casing may be pressed or loaded against the interior surface of the windshield to position or locate the image sensor in close proximity to the windshield and/or to optically couple the image sensor at the windshield. The mounting structure and/or mirror casing may include an aperture or apertures at its forward facing or mounting surface and the windshield

may include apertures through the opaque frit layer (typically disposed at a mirror mounting location of a windshield) or the windshield may not include such a frit layer, depending on the particular application.

Optionally, the image sensor may be operable in conjunction with a forward or rearward vision system, such as an automatic headlamp control system and/or a lane departure warning system or object detection system and/or other forward vision or imaging systems, such as imaging or vision systems of the types described in U.S. Pat. Nos. 7,038,577; 7,005,974; 7,004,606; 6,690,268; 6,946,978; 6,757,109; 6,717,610; 6,396,397; 6,201,642; 6,353,392; 6,313,454; 5,550,677; 5,670,935; 5,796,094; 5,715,093; 5,877,897; 6,097,023 and 6,498,620, and/or U.S. patent application Ser. No. 09/441,341, filed Nov. 16, 1999, now U.S. Pat. No. 7,339,149; Ser. No. 10/422,512, filed Apr. 24, 2003, now U.S. Pat. No. 7,123,168; Ser. No. 11/239,980, filed Sep. 30, 2005, now U.S. Pat. No. 7,881,496; Ser. No. 11/672,070, filed Feb. 7, 2007, now U.S. Pat. No. 8,698,894; and/or Ser. No. 11/315,675, filed Dec. 22, 2005, now U.S. Pat. No. 7,720,580, and/or U.S. provisional applications, Ser. No. 60/628,709, filed Nov. 17, 2004; Ser. No. 60/614,644, filed Sep. 30, 2004; Ser. No. 60/618,686, filed Oct. 14, 2004; Ser. No. 60/731,183, filed Oct. 28, 2005; and/or Ser. No. 60/765,797, filed Feb. 7, 2006, and/or International PCT Application No. PCT/US2006/041709, filed Oct. 27, 2006, and published May 10, 2007 as International Publication No. WO 07/053404, which are hereby incorporated herein by reference in their entirety. The mirror casing thus may support one or more rearward facing imaging sensors or cameras, such as for rearward vision or imaging systems, such as for a rear vision system or back up aid of the types described in U.S. Pat. Nos. 6,717,610 and/or 6,201,642 (which are hereby incorporated herein by reference in their entirety), and/or a cabin monitoring system or baby view system of the types described in U.S. Pat. No. 6,690,268 (which is hereby incorporated herein by reference in its entirety), and/or the like.

Optionally, the fixed mounting structure and/or mirror casing and/or windshield electronics module may house or support a display device, such as a heads up display device (such as the types described in U.S. patent application Ser. No. 11/105,757, filed Apr. 14, 2005, now U.S. Pat. No. 7,526,103; and Ser. No. 11/029,695, filed Jan. 5, 2005, now U.S. Pat. No. 7,253,723, which are hereby incorporated herein by reference in their entirety) that is operable to project a display at the area in front of the driver to enhance viewing of the display information without adversely affecting the driver's forward field of view. For example, the mirror casing may support a heads up display (HUD), such as a MicroHUD™ head-up display system available from MicroVision Inc. of Bothell, Wash., and/or such as a HUD that utilizes aspects described in U.S. patent application Ser. No. 11/105,757, filed Apr. 14, 2005, now U.S. Pat. No. 7,526,103; and Ser. No. 11/029,695, filed Jan. 5, 2005, now U.S. Pat. No. 7,253,723, which are hereby incorporated herein by reference in their entirety. For example, MicroVision's MicroHUD™ combines a MEMS-based micro display with an optical package of lenses and mirrors to achieve a compact high-performance HUD module that reflects a virtual image off the windscreen that appears to the driver to be close to the front of the car. This laser-scanning display can outperform many miniature flat panel LCD display screens because it can be clearly viewed in the brightest conditions and also dimmed to the very low brightness levels required for safe night-time driving. For example, such a display device may be located at or in the

mirror casing/mounting structure/windshield electronics module and may be non-movably mounted at the mirror casing or mounting structure or windshield electronics module, and may be operable to project the display information at the windshield of the vehicle so as to be readily viewed by the driver of the vehicle in the driver's forward field of view.

The mounting structure and/or mirror casing and/or windshield electronics module may be fixedly attached to or supported at the vehicle windshield and may extend upward toward the headliner of the vehicle. Thus, the mirror assembly of the present invention may have enhanced wire management and may substantially conceal the wiring of the electronic components/accessories between the circuitry within the mirror casing and the headliner at the upper portion of the vehicle windshield. Optionally, the mirror assembly may include wire management elements, such as the types described in U.S. patent application Ser. No. 11/226,628, filed Sep. 14, 2005, and published Mar. 23, 2006 as U.S. Publication No. 2006/0061008; and/or Ser. No. 11/584,697, filed Oct. 20, 2006, now U.S. Pat. No. 7,510,287; and/or U.S. provisional application, Ser. No. Ser. No. 60/729,430, filed Oct. 21, 2005, which are hereby incorporated herein by reference in their entirety, to conceal the wires extending between an upper portion of the mirror casing and the vehicle headliner (or overhead console). Optionally, the mirror casing and/or mounting structure and/or windshield electronics module may abut the headliner and/or may be an extension of an overhead console of the vehicle (such as by utilizing aspects described in U.S. patent application Ser. No. 10/538,724, filed Jun. 13, 2005 and published Mar. 9, 2006 as U.S. Publication No. 2006/0050018, and/or U.S. patent application Ser. No. 10/510,813, filed Aug. 23, 2002, now U.S. Pat. No. 7,306,276, which are hereby incorporated herein by reference in their entirety). The mirror assembly of the present invention thus may allow for utilization of the area above the mirror reflective element for additional mirror content, such as additional electronic accessories or circuitry, and thus may provide for or accommodate additional mirror content/circuitry and/or vehicle content/circuitry.

Optionally, the mirror assembly and/or reflective element assembly may include one or more displays, such as for the accessories or circuitry described herein. The displays may comprise any suitable display, such as displays of the types described in U.S. Pat. Nos. 5,530,240 and/or 6,329,925, which are hereby incorporated herein by reference in their entirety, or may be display-on-demand or transfective type displays or other displays, such as the types described in U.S. Pat. Nos. 6,690,268; 5,668,663 and/or 5,724,187, and/or U.S. patent application Ser. No. 10/054,633, filed Jan. 22, 2002, now U.S. Pat. No. 7,195,381; Ser. No. 11/021,065, filed Dec. 23, 2004, now U.S. Pat. No. 7,255,451; Ser. No. 10/528,269, filed Mar. 17, 2005, now U.S. Pat. No. 7,274,501; Ser. No. 10/533,762, filed May 4, 2005, now U.S. Pat. No. 7,184,190; Ser. No. 10/538,724, filed Jun. 13, 2005 and published Mar. 9, 2006 as U.S. Publication No. 2006/0050018; Ser. No. 11/226,628, filed Sep. 14, 2005 and published Mar. 23, 2006 as U.S. Publication No. 2006/0061008; Ser. No. 10/993,302, filed Nov. 19, 2004, now U.S. Pat. No. 7,338,177; and/or Ser. No. 11/284,543, filed Nov. 22, 2005, now U.S. Pat. No. 7,370,983, and/or PCT Patent Application No. PCT/US2006/018567, filed May 15, 2006 and published Nov. 23, 2006 as International Publication No. WO 2006/124682; and/or PCT Application No. PCT/US2006/042718, filed Oct. 31, 2006, and published May 10, 2007 as International Publication No. WO

07/053710; and/or U.S. provisional applications, Ser. No. 60/836,219, filed Aug. 8, 2006; Ser. No. 60/759,992, filed Jan. 18, 2006; and Ser. No. 60/732,245, filed Nov. 1, 2005, and/or PCT Application No. PCT/US03/40611, filed Dec. 19, 2003 and published Jul. 15, 2004 as International Publication No. WO 2004/058540, which are all hereby incorporated herein by reference in their entireties, or may include or incorporate video displays or the like, such as the types described in U.S. Pat. No. 6,690,268 and/or PCT Application No. PCT/US03/40611, filed Dec. 19, 2003 and published Jul. 15, 2004 as International Publication No. WO 2004/058540, U.S. patent application Ser. No. 10/538,724, filed Jun. 13, 2005, and published Mar. 9, 2006 as U.S. Publication No. 2006/0050018; and/or Ser. No. 11/284,543, filed Nov. 22, 2005, now U.S. Pat. No. 7,370,983, which are hereby incorporated herein by reference in their entireties. Optionally, the mirror assembly may include a video display that is selectively positionable, such as extendable/retractable or pivotable or foldable so as to be selectively positioned at a side or below the mirror casing when in use and storable within or at least partially within the mirror casing when not in use. The display may automatically extend/pivot to the in-use position in response to an actuating event, such as when the vehicle is shifted into its reverse gear for a rear vision system or back up aid.

Such a video mirror display (or other display) may be associated with a rearward facing camera at a rear of the vehicle and having a rearward field of view, such as at the license plate holder of the vehicle or at a rear trim portion (such as described in U.S. patent application Ser. No. 11/672,070, filed Feb. 7, 2007, now U.S. Pat. No. 8,698,894, and U.S. provisional application Ser. No. 60/765,797, filed Feb. 7, 2006, which is hereby incorporated herein by reference in its entirety). The image data captured by the rearward facing camera may be communicated to the control or video display at the rearview mirror assembly (or elsewhere in the vehicle, such as at an overhead console or accessory module or the like) via any suitable communication means or protocol. For example, the image data may be communicated via a fiber optic cable or a twisted pair of wires, or may be communicated wirelessly, such as via a BLUETOOTH® communication link or protocol or the like, or may be superimposed on a power line, such as a 12 volt power line of the vehicle, such as by utilizing aspects of the systems described in U.S. patent application Ser. No. 11/239,980, filed Sep. 30, 2005, now U.S. Pat. No. 7,881,496, which is hereby incorporated herein by reference in its entirety.

Optionally, the mirror assembly may include one or more user inputs for controlling or activating/deactivating one or more electrical accessories or devices of or associated with the mirror assembly. For example, the mirror assembly may comprise any type of switches or buttons, such as touch or proximity sensing switches, such as touch or proximity switches of the types described in PCT Application No. PCT/US03/40611, filed Dec. 19, 2003 and published Jul. 15, 2004 as International Publication No. WO 2004/058540; and/or PCT Application No. PCT/US2004/015424, filed May 18, 2004 and published Dec. 2, 2004 as International Publication No. WO 2004/103772, and/or U.S. Pat. Nos. 6,001,486; 6,310,611; 6,320,282 and 6,627,918, and/or U.S. patent application Ser. No. 11/021,065, filed Dec. 23, 2004, now U.S. Pat. No. 7,255,451; and/or U.S. patent application Ser. No. 09/817,874, filed Mar. 26, 2001, now U.S. Pat. No. 7,224,324; Ser. No. 10/956,749, filed Oct. 1, 2004, now U.S. Pat. No. 7,446,924; Ser. No. 10/933,842, filed Sep. 3, 2004, now U.S. Pat. No. 7,249,860; Ser. No. 11/021,065, filed Dec.

23, 2004, now U.S. Pat. No. 7,255,451; and/or Ser. No. 11/140,396, filed May 27, 2005, now U.S. Pat. No. 7,360,932, which are hereby incorporated herein by reference in their entireties, or the inputs may comprise other types of buttons or switches, such as those described in U.S. Pat. No. 6,501,387, and/or U.S. patent application Ser. No. 11/029,695, filed Jan. 5, 2005, now U.S. Pat. No. 7,253,723; and/or Ser. No. 11/451,639, filed Jun. 13, 2006, now U.S. Pat. No. 7,527,403, which are hereby incorporated herein by reference in their entireties, or such as fabric-made position detectors, such as those described in U.S. Pat. Nos. 6,504,531; 6,501,465; 6,492,980; 6,452,479; 6,437,258 and 6,369,804, which are hereby incorporated herein by reference in their entireties. Other types of switches or buttons or inputs or sensors may be incorporated to provide the desired function, without affecting the scope of the present invention. The manual inputs or user actuatable inputs or actuators may control or adjust or activate/deactivate one or more accessories or elements or features. For touch sensitive inputs or applications or switches, the mirror assembly or accessory module or input may, when activated, provide a positive feedback (such as activation of an illumination source or the like, or such as via an audible signal, such as a chime or the like, or a tactile or haptic signal, or a rumble device or signal or the like) to the user so that the user is made aware that the input was successfully activated.

Optionally, the user inputs or buttons may comprise user inputs for a garage door opening system, such as a vehicle based garage door opening system of the types described in U.S. Pat. Nos. 7,023,322; 6,396,408; 6,362,771 and 5,798,688, which are hereby incorporated herein by reference in their entireties. The user inputs may also or otherwise function to activate and deactivate a display or function or accessory, and/or may activate/deactivate and/or commence a calibration of a compass system of the mirror assembly and/or vehicle. Optionally, the user inputs may also or otherwise comprise user inputs for a telematics system of the vehicle, such as, for example, an ONSTAR® system as found in General Motors vehicles and/or such as described in U.S. Pat. Nos. 4,862,594; 4,937,945; 5,131,154; 5,255,442; 5,632,092; 5,798,688; 5,971,552; 5,924,212; 6,243,003; 6,278,377; 6,420,975; 6,946,978; 6,477,464; 6,678,614 and/or 7,004,593, and/or U.S. patent application Ser. No. 10/645,762, filed Aug. 20, 2003, now U.S. Pat. No. 7,167,796; Ser. No. 10/529,715, filed Mar. 30, 2005, now U.S. Pat. No. 7,657,052; Ser. No. 10/538,724, filed Jun. 13, 2005 and published Mar. 9, 2006 as U.S. Publication No. 2006/0050018; and/or Ser. No. 10/964,512, filed Oct. 13, 2004, now U.S. Pat. No. 7,308,341, which are all hereby incorporated herein by reference in their entireties.

Optionally, the display and inputs may be associated with various accessories or systems, such as, for example, a tire pressure monitoring system or a passenger air bag status or a garage door opening system or a telematics system or any other accessory or system of the mirror assembly or of the vehicle or of an accessory module or console of the vehicle, such as an accessory module or console of the types described in U.S. Pat. Nos. 6,877,888; 6,690,268; 6,824,281; 6,672,744; 6,386,742 and 6,124,886, and/or PCT Application No. PCT/US03/40611, filed Dec. 19, 2003 and published Jul. 15, 2004 as International Publication No. WO 2004/058540, and/or PCT Application No. PCT/US04/15424, filed May 18, 2004 and published Dec. 2, 2004 as International Publication No. WO 2004/103772, and/or U.S. patent application Ser. No. 10/510,813, filed Aug. 23, 2002, now U.S. Pat. No. 7,306,276, which are hereby incorporated herein by reference in their entireties.

Optionally, the mirror assembly or accessory module may fixedly or non-movably support one or more other accessories or features, such as one or more electrical or electronic devices or accessories. For example, illumination sources or lights, such as map reading lights or one or more other lights or illumination sources, such as illumination sources of the types disclosed in U.S. Pat. Nos. 6,690,268; 5,938,321; 5,813,745; 5,820,245; 5,673,994; 5,649,756; 5,178,448; 5,671,996; 4,646,210; 4,733,336; 4,807,096; 6,042,253; 6,971,775 and/or 5,669,698, and/or U.S. patent application Ser. No. 10/054,633, filed Jan. 22, 2002, now U.S. Pat. No. 7,195,381; and/or Ser. No. 10/933,842, filed Sep. 3, 2004, now U.S. Pat. No. 7,249,860, which are hereby incorporated herein by reference in their entireties, may be included in the mirror assembly. The illumination sources and/or the circuit board may be connected to one or more buttons or inputs for activating and deactivating the illumination sources.

Optionally, the mirror assembly may also or otherwise include other accessories, such as microphones, such as analog microphones or digital microphones or the like, such as microphones of the types disclosed in U.S. Pat. Nos. 6,243,003; 6,278,377 and/or 6,420,975, and/or U.S. patent application Ser. No. 10/529,715, filed Mar. 30, 2005, now U.S. Pat. No. 7,657,052. Optionally, the mirror assembly may also or otherwise include other accessories, such as a telematics system, speakers, antennas, including global positioning system (GPS) or cellular phone antennas, such as disclosed in U.S. Pat. No. 5,971,552, a communication module, such as disclosed in U.S. Pat. No. 5,798,688, a voice recorder, a blind spot detection and/or indication system, such as disclosed in U.S. Pat. Nos. 7,038,577; 6,882,287; 5,929,786 and/or 5,786,772, and/or U.S. patent application Ser. No. 11/315,675, filed Dec. 22, 2005, now U.S. Pat. No. 7,720,580; and/or PCT Application No. PCT/US2006/026148, filed Jul. 5, 2006 and published Jan. 11, 2007 as International Publication No. WO 2007/005942, transmitters and/or receivers, such as for a garage door opener or a vehicle door unlocking system or the like (such as a remote keyless entry system), a digital network, such as described in U.S. Pat. No. 5,798,575, a hands-free phone attachment, an imaging system or components or circuitry or display thereof, such as an imaging and/or display system of the types described in U.S. Pat. Nos. 6,690,268 and 6,847,487; and/or U.S. provisional applications, Ser. No. 60/614,644, filed Sep. 30, 2004; Ser. No. 60/618,686, filed Oct. 14, 2004; and/or Ser. No. 60/628,709, filed Nov. 17, 2004; and/or U.S. patent application Ser. No. 11/105,757, filed Apr. 14, 2005, now U.S. Pat. No. 7,526,103; Ser. No. 11/334,139, filed Jan. 18, 2006, now U.S. Pat. No. 7,400,435; and/or Ser. No. 11/239,980, filed Sep. 30, 2005, now U.S. Pat. No. 7,881,496, a video device for internal cabin surveillance (such as for sleep detection or driver drowsiness detection or the like) and/or video telephone function, such as disclosed in U.S. Pat. Nos. 5,760,962 and/or 5,877,897, an occupant detection system and/or interior cabin monitoring system (such as the types described in U.S. Pat. Nos. 6,019,411 and/or 6,690,268, and/or PCT Application No. PCT/US2005/042504, filed Nov. 22, 2005 and published Jun. 1, 2006 as International Publication No. WO 2006/058098; and/or PCT Application No. PCT/US94/01954, filed Feb. 25, 1994, a heating element, particularly for an exterior mirror application, such as the types described in U.S. patent application Ser. No. 11/334,139, filed Jan. 18, 2006, now U.S. Pat. No. 7,400,435, a remote keyless entry receiver, a seat occupancy detector, a remote starter control, a yaw sensor, a clock, a carbon monoxide detector, status displays, such as displays that display a status of a door of

the vehicle, a transmission selection (4wd/2wd or traction control (TCS) or the like), an antilock braking system, a road condition (that may warn the driver of icy road conditions) and/or the like, a trip computer, a tire pressure monitoring system (TPMS) receiver (such as described in U.S. Pat. Nos. 6,124,647; 6,294,989; 6,445,287; 6,472,979; 6,731,205, and/or U.S. patent application Ser. No. 11/232,324, filed Sep. 21, 2005, now U.S. Pat. No. 7,423,522, and/or an ONSTAR® system and/or any other accessory or circuitry or the like (with all of the above-referenced U.S. patents and PCT applications and U.S. patent applications and U.S. provisional applications being commonly assigned, and with the disclosures of the referenced U.S. patents and PCT applications and U.S. patent applications and U.S. provisional applications being hereby incorporated herein by reference in their entireties).

Changes and modifications to the specifically described embodiments may be carried out without departing from the principles of the present invention, which is intended to be limited only by the scope of the appended claims as interpreted according to the principles of patent law.

The invention claimed is:

1. A forward facing sensing system for a vehicle, the vehicle having a windshield, said forward facing sensing system comprising:

a radar sensor disposed within an interior cabin of a vehicle equipped with said forward facing sensing system;

wherein said radar sensor has a sensing direction forward of the equipped vehicle;

wherein said radar sensor transmits at a frequency of at least 60 GHz;

wherein said radar sensor utilizes digital beam forming in a phased array antenna system;

an image sensor disposed within the interior cabin of the equipped vehicle behind the vehicle windshield;

wherein said image sensor views forward of the equipped vehicle through the vehicle windshield;

wherein said image sensor comprises a pixelated imaging array sensor comprising a plurality of photo-sensing pixels;

wherein said radar sensor and said image sensor are housed in a self-contained unit disposed behind and attached at the vehicle windshield of the equipped vehicle;

wherein said self-contained unit mounts at the vehicle windshield of the equipped vehicle and is removable therefrom as a unit for at least one of service and replacement;

a control comprising an image processor, said image processor operable to analyze image data captured by said image sensor in order to, at least in part, detect an object present exterior of the equipped vehicle in a direction of forward travel of the equipped vehicle;

wherein said image processor comprises an image processing chip that processes image data captured by said image sensor utilizing object detection software;

wherein said control, responsive at least in part to processing of captured image data by said image processor and to sensing by said radar sensor, determines that a potentially hazardous condition may exist in the path of forward travel of the equipped vehicle, and wherein said potentially hazardous condition comprises the detected object being in the path of forward travel of the equipped vehicle;

wherein said radar sensor and said image sensor collaborate in a way that enhances sensing capability of said

17

sensing system for the object in the path of forward travel of the equipped vehicle;
 wherein said radar sensor and said image sensor share, at least in part, common circuitry;
 wherein said control at least in part controls an adaptive cruise control system of the equipped vehicle; and
 wherein said image processor processes image data captured by said image sensor for an automatic headlamp control system of the equipped vehicle.

2. The sensing system of claim 1, wherein, responsive to determination by said control that a potentially hazardous condition may exist in the path of forward travel of the equipped vehicle and that said potentially hazardous condition comprises the detected object in the path of forward travel of the equipped vehicle, at least one of a visual alert and an audible alert is provided to alert a driver of the equipped vehicle to the determined potentially hazardous condition.

3. The sensing system of claim 2, wherein video images captured by said image sensor are displayed on a video display screen viewable to a driver of the equipped vehicle, and wherein, responsive to determination by said control that a potentially hazardous condition may exist in the path of forward travel of the equipped vehicle and that said potentially hazardous condition comprises a pedestrian in the path of forward travel of the equipped vehicle, a visual alert is displayed by said video display screen to alert the driver of the equipped vehicle to the determined potentially hazardous condition.

4. The sensing system of claim 3, wherein said image sensor is part of a night vision system of the equipped vehicle.

5. The sensing system of claim 2, wherein said at least one of a visual alert and an audible alert is provided episodically.

6. The sensing system of claim 1, wherein said image processor is operable to undertake enhanced processing of pixel outputs of pixels of said image sensor that are within a sub-array of said pixelated imaging array.

7. The sensing system of claim 6, wherein an object associated with said potentially hazardous condition is detected at least at said sub-array of said pixelated imaging array.

8. The sensing system of claim 7, wherein the detected object is a pedestrian.

9. The sensing system of claim 1, wherein the detected object is a pedestrian.

10. The sensing system of claim 1, wherein the detected object is a deer.

11. The sensing system of claim 1, wherein the vehicle windshield comprises an opaque layer generally where said self-contained unit is disposed behind the vehicle windshield, and wherein said opaque layer comprises a light-transmitting aperture, and wherein, with said self-contained unit attached at the vehicle windshield, said image sensor views forward of the equipped vehicle via said light-transmitting aperture.

12. The sensing system of claim 11, wherein said radar sensor transmits at a frequency of at least 77 GHz.

13. The sensing system of claim 11, wherein said radar sensor transmits at 79 GHz.

14. The sensing system of claim 11, wherein said image sensor views through the vehicle windshield at a location that is at or near where an interior rearview mirror assembly of the equipped vehicle is mounted at the vehicle windshield.

15. The sensing system of claim 14, wherein said self-contained unit mounts at the vehicle windshield of the

18

equipped vehicle separate and spaced from where the interior rearview mirror assembly of the equipped vehicle mounts at the vehicle windshield.

16. The sensing system of claim 1, wherein said image processor and said common circuitry are housed in said self-contained unit disposed behind and attached at the vehicle windshield of the equipped vehicle.

17. The sensing system of claim 16, wherein said image processor processes image data captured by said image sensor for a lane departure warning system of the equipped vehicle.

18. The sensing system of claim 1, wherein said common circuitry includes said image processor.

19. A forward facing sensing system for a vehicle, the vehicle having a windshield, said forward facing sensing system comprising:

a radar sensor disposed within an interior cabin of a vehicle equipped with said forward facing sensing system;

wherein said radar sensor has a sensing direction forward of the equipped vehicle;

wherein said radar sensor transmits at a frequency of at least 60 GHz;

wherein said radar sensor utilizes digital beam forming in a phased array antenna system;

an image sensor disposed within the interior cabin of the equipped vehicle behind the vehicle windshield;

wherein said image sensor views forward of the equipped vehicle through the vehicle windshield;

wherein said image sensor comprises a pixelated imaging array sensor comprising a plurality of photo-sensing pixels;

wherein said radar sensor and said image sensor are housed in a self-contained unit disposed behind and attached at the vehicle windshield of the equipped vehicle;

wherein said self-contained unit mounts at the vehicle windshield of the equipped vehicle and is removable therefrom as a unit for at least one of service and replacement;

a control comprising an image processor, said image processor operable to analyze image data captured by said image sensor in order to, at least in part, detect an object present exterior of the equipped vehicle in a direction of forward travel of the equipped vehicle;

wherein said image processor comprises an image processing chip that processes image data captured by said image sensor utilizing object detection software;

wherein said control, responsive at least in part to processing of captured image data by said image processor and to sensing by said radar sensor, determines that a potentially hazardous condition may exist in the path of forward travel of the equipped vehicle, and wherein said potentially hazardous condition comprises the detected object being in the path of forward travel of the equipped vehicle;

wherein said radar sensor and said image sensor collaborate in a way that enhances determination of existence of the potentially hazardous condition in the path of forward travel of the equipped vehicle;

wherein said radar sensor and said image sensor share, at least in part, common circuitry;

wherein said image sensor views through the vehicle windshield at a location that is at or near where an interior rearview mirror assembly of the equipped vehicle is mounted at the vehicle windshield;

19

wherein said self-contained unit mounts at the vehicle windshield of the equipped vehicle separate and spaced from where the interior rearview mirror assembly of the equipped vehicle mounts at the vehicle windshield; wherein the vehicle windshield comprises an opaque layer generally where said self-contained unit is disposed behind the vehicle windshield, and wherein said opaque layer comprises a light-transmitting aperture; wherein, with said self-contained unit attached at the vehicle windshield, said image sensor views forward of the equipped vehicle via said light-transmitting aperture; and

wherein, responsive to determination by said control that a potentially hazardous condition may exist in the path of forward travel of the equipped vehicle and that said potentially hazardous condition comprises an object in the path of forward travel of the equipped vehicle, at least one of a visual alert and an audible alert is provided to alert a driver of the equipped vehicle to the determined potentially hazardous condition.

20. The sensing system of claim 19, wherein said image processor and said common circuitry are housed in said self-contained unit disposed behind and attached at the vehicle windshield of the equipped vehicle.

21. The sensing system of claim 20, wherein said common circuitry includes said image processor.

22. The sensing system of claim 21, wherein said control at least in part controls an adaptive cruise control system of the equipped vehicle.

23. The sensing system of claim 21, wherein said image processor processes image data captured by said image sensor for an automatic headlamp control system of the equipped vehicle.

24. A forward facing sensing system for a vehicle, the vehicle having a windshield, said forward facing sensing system comprising:

a radar sensor disposed within an interior cabin of a vehicle equipped with said forward facing sensing system;

wherein said radar sensor has a sensing direction forward of the equipped vehicle;

wherein said radar sensor transmits at a frequency of at least 60 GHz;

wherein said radar sensor utilizes digital beam forming in a phased array antenna system;

an image sensor disposed within the interior cabin of the equipped vehicle behind the vehicle windshield;

wherein said image sensor views forward of the equipped vehicle through the vehicle windshield;

wherein said image sensor comprises a pixelated imaging array sensor comprising a plurality of photo-sensing pixels;

wherein said radar sensor and said image sensor are housed in a self-contained unit disposed behind and attached at the vehicle windshield of the equipped vehicle;

wherein said self-contained unit mounts at the vehicle windshield of the equipped vehicle and is removable therefrom as a unit for at least one of service and replacement;

a control comprising an image processor, said image processor operable to analyze image data captured by said image sensor in order to, at least in part, detect a

20

pedestrian present exterior of the equipped vehicle in a direction of forward travel of the equipped vehicle;

wherein said image processor comprises an image processing chip that processes image data captured by said image sensor utilizing object detection software;

wherein said control, responsive at least in part to processing of captured image data by said image processor and to sensing by said radar sensor, determines that a potentially hazardous condition may exist in the path of forward travel of the equipped vehicle, and wherein said potentially hazardous condition comprises the detected pedestrian being in the path of forward travel of the equipped vehicle;

wherein said radar sensor and said image sensor collaborate in a way that enhances determination of existence of the potentially hazardous condition in the path of forward travel of the equipped vehicle;

wherein said radar sensor and said image sensor collaborate in a way that enhances sensing capability of said sensing system for the pedestrian in the path of forward travel of the equipped vehicle;

wherein said radar sensor and said image sensor share, at least in part, common circuitry;

wherein said image processor and said common circuitry are housed in said self-contained unit disposed behind and attached at the vehicle windshield of the equipped vehicle;

wherein said common circuitry includes said image processor;

wherein said image sensor views through the vehicle windshield at a location that is at or near where an interior rearview mirror assembly of the equipped vehicle is mounted at the vehicle windshield;

wherein said self-contained unit mounts at the vehicle windshield of the equipped vehicle separate and spaced from where the interior rearview mirror assembly of the equipped vehicle mounts at the vehicle windshield;

wherein the vehicle windshield comprises an opaque layer generally where said self-contained unit is disposed behind the vehicle windshield, and wherein said opaque layer comprises a light-transmitting aperture; and

wherein, with said self-contained unit attached at the vehicle windshield, said image sensor views forward of the equipped vehicle via said light-transmitting aperture.

25. The sensing system of claim 24, wherein, responsive to determination by said control that a potentially hazardous condition may exist in the path of forward travel of the equipped vehicle and that said potentially hazardous condition comprises an object in the path of forward travel of the equipped vehicle, at least one of a visual alert and an audible alert is provided to alert a driver of the equipped vehicle to the determined potentially hazardous condition.

26. The sensing system of claim 25, wherein said control at least in part controls an adaptive cruise control system of the equipped vehicle.

27. The sensing system of claim 25, wherein said image processor processes image data captured by said image sensor for an automatic headlamp control system of the equipped vehicle.

* * * * *