



US009989638B2

(12) **United States Patent**
Harris et al.

(10) **Patent No.:** **US 9,989,638 B2**
(45) **Date of Patent:** **Jun. 5, 2018**

(54) **ADAPTIVE FILTERING FOR FMCW INTERFERENCE MITIGATION IN PMCW RADAR SYSTEMS**

(71) Applicant: **UHNDER, INC.**, Austin, TX (US)
(72) Inventors: **Fred Harris**, Lemon Grove, CA (US); **David Trager**, Buda, TX (US); **Curtis Davis**, St. Louis, MO (US); **Raghunath K. Rao**, Austin, TX (US)
(73) Assignee: **Uhnder, Inc.**, Austin, TX (US)

(*) Notice: Subject to any disclaimer, the term of this patent is extended or adjusted under 35 U.S.C. 154(b) by 0 days. days.

(21) Appl. No.: **15/782,304**

(22) Filed: **Oct. 12, 2017**

(65) **Prior Publication Data**
US 2018/0031697 A1 Feb. 1, 2018

Related U.S. Application Data
(63) Continuation of application No. 15/492,160, filed on Apr. 20, 2017, now Pat. No. 9,791,564.
(Continued)

(51) **Int. Cl.**
G01S 13/93 (2006.01)
G01S 13/34 (2006.01)
G01S 13/00 (2006.01)

(52) **U.S. Cl.**
CPC **G01S 13/931** (2013.01); **G01S 13/34** (2013.01); **G01S 13/93** (2013.01)

(58) **Field of Classification Search**
CPC G01S 13/34; G01S 13/93; G01S 13/325; H03H 21/0018; H03H 21/0005
See application file for complete search history.

(56) **References Cited**
U.S. PATENT DOCUMENTS

1,882,128 A 10/1932 Fearing
3,374,478 A 3/1968 Blau
(Continued)

FOREIGN PATENT DOCUMENTS

EP 0725480 11/2011
EP 2374217 4/2013
(Continued)

OTHER PUBLICATIONS

Chambers et al., An article entitled "Real-Time Vehicle Mounted Multistatic Ground Penetrating Radar Imaging System for Buried Object Detection," Lawrence Livermore National Laboratory Reports (LLNL-TR-615452), Feb. 4, 2013; Retrieved from the Internet from <https://e-reports-ext.llnl.gov/pdf/711892.pdf>.
(Continued)

Primary Examiner — Bernarr E Gregory
(74) *Attorney, Agent, or Firm* — Gardner, Linn, Burkhardt & Ondersma, LLP

(57) **ABSTRACT**

A radar sensing system for a vehicle includes a transmitter, a receiver, a processor and an adaptive filter. The transmitter is configured to transmit a radio signal. The receiver is configured to receive radio signals that include the transmitted radio signal reflected from objects in the environment, as well as further including other radio signals transmitted from at least one other radar sensing system. The receiver is further configured to produce a sampled stream. The sampled stream is provided to the processor. The processor, responsive to further processing of the sampled stream, controls the adaptive filter to filter the sampled stream, such that the other radio signals transmitted from the at least one other radar sensing system are removed from the received radio signal.

27 Claims, 14 Drawing Sheets

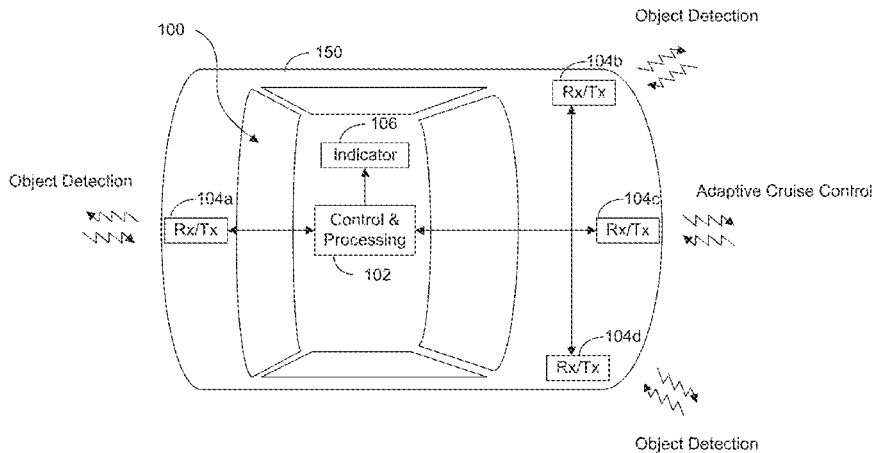

Related U.S. Application Data

- (60) Provisional application No. 62/450,184, filed on Jan. 25, 2017, provisional application No. 62/327,005, filed on Apr. 25, 2016.

References Cited

U.S. PATENT DOCUMENTS

3,735,398 A 5/1973 Ross
 3,750,169 A 7/1973 Strenglein
 3,896,434 A 7/1975 Sirven
 4,078,234 A 3/1978 Fishbein et al.
 4,176,351 A 11/1979 De Vita et al.
 4,566,010 A 1/1986 Collins
 4,882,668 A * 11/1989 Schmid et al. H03H 21/0018
 4,939,685 A 7/1990 Feintuch
 5,001,486 A 3/1991 Bächtiger
 5,034,906 A 7/1991 Chang
 5,087,918 A 2/1992 May et al.
 5,151,702 A 9/1992 Urkowitz
 5,175,710 A 12/1992 Hutson
 5,218,619 A 6/1993 Dent
 5,272,663 A * 12/1993 Jones et al. H03H 21/0005
 5,280,288 A 1/1994 Sherry et al.
 5,302,956 A 4/1994 Asbury et al.
 5,341,141 A 8/1994 Frazier et al.
 5,345,470 A 9/1994 Alexander
 5,379,322 A 1/1995 Kosaka et al.
 5,497,162 A * 3/1996 Kaiser G01S 13/931
 5,508,706 A 4/1996 Tsou et al.
 5,657,021 A * 8/1997 Ehsani-Nategh et al. G01S 13/931
 5,657,023 A 8/1997 Lewis et al.
 5,712,640 A 1/1998 Andou et al.
 5,724,041 A 3/1998 Inoue et al.
 5,892,477 A 4/1999 Wehling
 5,917,430 A 6/1999 Greneker, III et al.
 5,920,285 A 7/1999 Benjamin
 5,931,893 A 8/1999 Dent et al.
 5,959,571 A 9/1999 Aoyagi et al.
 5,970,400 A 10/1999 Dwyer
 6,067,314 A 5/2000 Azuma
 6,069,581 A 5/2000 Bell et al.
 6,121,872 A 9/2000 Weishaupt
 6,121,918 A 9/2000 Tullsson
 6,151,366 A 11/2000 Yip
 6,163,252 A 12/2000 Nishiwaki
 6,184,829 B1 2/2001 Stilp
 6,191,726 B1 2/2001 Tullsson
 6,288,672 B1 9/2001 Asano et al.
 6,307,622 B1 10/2001 Lewis
 6,347,264 B2 2/2002 Nicosia et al.
 6,400,308 B1 6/2002 Bell et al.
 6,411,250 B1 6/2002 Oswald et al.
 6,417,796 B1 7/2002 Bowlds
 6,424,289 B2 * 7/2002 Fukae et al. G01S 13/325
 6,583,753 B1 6/2003 Reed
 6,614,387 B1 9/2003 Deadman
 6,624,784 B1 9/2003 Yamaguchi
 6,674,908 B1 1/2004 Aronov
 6,714,956 B1 3/2004 Liu et al.
 6,747,595 B2 6/2004 Hirabe
 6,768,391 B1 7/2004 Dent et al.
 6,975,246 B1 12/2005 Trudeau
 7,119,739 B1 10/2006 Struckman
 7,289,058 B2 10/2007 Shima
 7,299,251 B2 11/2007 Skidmore et al.
 7,338,450 B2 3/2008 Kristofferson et al.
 7,395,084 B2 7/2008 Anttila
 7,460,055 B2 12/2008 Nishijima et al.
 7,545,310 B2 6/2009 Matsuoka
 7,545,321 B2 6/2009 Kawasaki
 7,564,400 B2 7/2009 Fukuda
 7,567,204 B2 7/2009 Sakamoto
 7,609,198 B2 10/2009 Chang
 7,642,952 B2 1/2010 Fukuda

7,663,533 B2 2/2010 Toennesen
 7,728,762 B2 6/2010 Sakamoto
 7,791,528 B2 9/2010 Klotzbuecher
 7,847,731 B2 12/2010 Wiesbeck et al.
 7,855,677 B2 12/2010 Negoro et al.
 7,859,450 B2 12/2010 Shirakawa et al.
 8,019,352 B2 9/2011 Rappaport et al.
 8,049,663 B2 11/2011 Frank et al.
 8,059,026 B1 11/2011 Nunez
 8,102,306 B2 1/2012 Smith, Jr. et al.
 8,154,436 B2 4/2012 Szajnowski
 8,330,650 B2 12/2012 Goldman
 8,390,507 B2 3/2013 Wintermantel
 8,471,760 B2 6/2013 Szajnowski
 8,532,159 B2 9/2013 Kagawa et al.
 8,547,988 B2 10/2013 Hadani et al.
 8,686,894 B2 4/2014 Fukuda et al.
 8,694,306 B1 4/2014 Short et al.
 9,121,943 B2 9/2015 Stirlin-Gallacher et al.
 9,239,378 B2 1/2016 Kishigami et al.
 9,239,379 B2 1/2016 Burgio et al.
 9,282,945 B2 3/2016 Smith et al.
 9,335,402 B2 5/2016 Maeno et al.
 9,541,639 B2 1/2017 Searcy et al.
 9,568,600 B2 2/2017 Alland
 9,575,160 B1 2/2017 Davis et al.
 9,599,702 B1 3/2017 Bordes et al.
 9,689,967 B1 6/2017 Stark et al.
 9,720,073 B1 8/2017 Davis et al.
 9,753,121 B1 9/2017 Davis et al.
 9,753,132 B1 9/2017 Bordes et al.
 9,772,397 B1 9/2017 Bordes et al.
 9,791,551 B1 10/2017 Eshraghi et al.
 9,791,564 B1 10/2017 Harris et al.
 9,806,914 B1 10/2017 Bordes et al.
 2001/0002919 A1 6/2001 Sourour et al.
 2002/0004692 A1 1/2002 Nicosia et al.
 2002/0044082 A1 4/2002 Woodington et al.
 2002/0075178 A1 6/2002 Woodington et al.
 2002/0118522 A1 8/2002 Ho et al.
 2002/0130811 A1 9/2002 Voigtlaender
 2002/0147534 A1 10/2002 Delcheccolo et al.
 2002/0155811 A1 10/2002 Prismantas
 2003/0001772 A1 1/2003 Woodington et al.
 2003/0011519 A1 1/2003 Breglia et al.
 2003/0058166 A1 3/2003 Hirabe
 2003/0102997 A1 6/2003 Levin et al.
 2003/0235244 A1 12/2003 Pessoa et al.
 2004/0012516 A1 1/2004 Schiffmann
 2004/0015529 A1 1/2004 Tanrikulu et al.
 2004/0066323 A1 4/2004 Richter
 2004/0138802 A1 7/2004 Kuragaki et al.
 2005/0069162 A1 3/2005 Haykin
 2005/0156780 A1 7/2005 Bonthron et al.
 2005/0201457 A1 9/2005 Allred et al.
 2005/0225476 A1 10/2005 Hoetzel et al.
 2006/0012511 A1 1/2006 Dooi et al.
 2006/0036353 A1 2/2006 Wintermantel
 2006/0050707 A1 3/2006 Sterin
 2006/0093078 A1 5/2006 Lewis et al.
 2006/0109170 A1 5/2006 Voigtlaender et al.
 2006/0109931 A1 5/2006 Asai
 2006/0114324 A1 6/2006 Farmer et al.
 2006/0140249 A1 6/2006 Kohno
 2006/0181448 A1 8/2006 Natsume et al.
 2006/0244653 A1 * 11/2006 Szajnowski G01S 13/931
 2006/0262007 A1 11/2006 Bonthron
 2006/0262009 A1 11/2006 Watanabe
 2007/0018884 A1 1/2007 Adams
 2007/0018886 A1 1/2007 Watanabe et al.
 2007/0109175 A1 5/2007 Fukuda
 2007/0120731 A1 5/2007 Kelly, Jr. et al.
 2007/0132633 A1 6/2007 Uchino
 2007/0152870 A1 7/2007 Woodington et al.
 2007/0152871 A1 7/2007 Puglia
 2007/0152872 A1 7/2007 Woodington
 2007/0164896 A1 7/2007 Suzuki et al.
 2007/0171122 A1 7/2007 Nakano
 2007/0182619 A1 8/2007 Honda et al.

(56)

References Cited

U.S. PATENT DOCUMENTS

2007/0182623 A1 8/2007 Zeng
 2007/0188373 A1 8/2007 Shirakawa et al.
 2007/0200747 A1 8/2007 Okai
 2007/0279303 A1 12/2007 Schoebel
 2008/0208472 A1 8/2008 Morcom
 2008/0272955 A1 11/2008 Yonak et al.
 2009/0015459 A1 1/2009 Mahler et al.
 2009/0015464 A1 1/2009 Fukuda
 2009/0051581 A1 2/2009 Hatono
 2009/0073025 A1 3/2009 Inoue et al.
 2009/0079617 A1 3/2009 Shirakawa et al.
 2009/0085827 A1 4/2009 Orime et al.
 2009/0121918 A1 5/2009 Shirai et al.
 2009/0212998 A1 8/2009 Szajnowski
 2009/0237293 A1 9/2009 Sakuma
 2009/0267822 A1 10/2009 Shinoda et al.
 2009/0289831 A1 11/2009 Akita
 2009/0295623 A1 12/2009 Falk
 2010/0116365 A1 5/2010 McCarty
 2010/0156690 A1 6/2010 Kim et al.
 2010/0198513 A1 8/2010 Zeng et al.
 2010/0277359 A1 11/2010 Ando
 2011/0006944 A1 1/2011 Goldman
 2011/0032138 A1 2/2011 Krapf
 2011/0187600 A1 8/2011 Landt
 2011/0196568 A1 8/2011 Nickolaou
 2011/0248796 A1 10/2011 Pozgay
 2011/0279303 A1 11/2011 Smith, Jr. et al.
 2011/0279307 A1 11/2011 Song
 2011/0285576 A1 11/2011 Lynam
 2011/0291874 A1 12/2011 De Mersseman
 2011/0291875 A1 12/2011 Szajnowski
 2011/0292971 A1 12/2011 Hadani et al.
 2011/0298653 A1 12/2011 Mizutani
 2012/0001791 A1 1/2012 Wintermantel
 2012/0050093 A1 3/2012 Heilmann et al.
 2012/0112957 A1 5/2012 Nguyen et al.
 2012/0133547 A1 5/2012 MacDonald et al.
 2012/0173246 A1 7/2012 Choi et al.
 2012/0257643 A1 10/2012 Wu et al.
 2012/0319900 A1 12/2012 Johansson et al.
 2013/0016761 A1 1/2013 Nentwig
 2013/0021196 A1 1/2013 Himmelstoss
 2013/0027240 A1 1/2013 Chowdhury
 2013/0069818 A1 3/2013 Shirakawa et al.
 2013/0102254 A1 4/2013 Cyzs
 2013/0113653 A1 5/2013 Kishigami et al.
 2013/0135140 A1 5/2013 Kishigami
 2013/0169485 A1 7/2013 Lynch
 2013/0176154 A1 7/2013 Bonaccio et al.
 2013/0214961 A1 8/2013 Lee et al.
 2013/0229301 A1 9/2013 Kanamoto
 2013/0244710 A1 9/2013 Nguyen et al.
 2013/0314271 A1 11/2013 Braswell et al.
 2013/0321196 A1 12/2013 Binzer et al.
 2014/0022108 A1 1/2014 Alberth, Jr. et al.
 2014/0028491 A1 1/2014 Ferguson
 2014/0035774 A1 2/2014 Khlifi

2014/0070985 A1 3/2014 Vacanti
 2014/0085128 A1 3/2014 Kishigami et al.
 2014/0111372 A1 4/2014 Wu
 2014/0159948 A1 6/2014 Ishimori et al.
 2014/0220903 A1 8/2014 Schulz et al.
 2014/0253345 A1 9/2014 Breed
 2014/0285373 A1 9/2014 Kuwahara et al.
 2014/0327566 A1 11/2014 Burgio et al.
 2014/0348253 A1 11/2014 Mobasher et al.
 2015/0002329 A1 1/2015 Murad et al.
 2015/0002357 A1 1/2015 Sanford et al.
 2015/0035662 A1 2/2015 Bowers et al.
 2015/0061922 A1 3/2015 Kishigami
 2015/0103745 A1 4/2015 Negus et al.
 2015/0198709 A1 7/2015 Inoue
 2015/0204966 A1 7/2015 Kishigami
 2015/0204971 A1 7/2015 Kuehnle
 2015/0226848 A1 8/2015 Park
 2015/0234045 A1 8/2015 Rosenblum
 2015/0247924 A1 9/2015 Kishigami
 2015/0301172 A1 10/2015 Ossowska
 2015/0323660 A1 11/2015 Hampikian
 2015/0331090 A1 11/2015 Jeong et al.
 2016/0003939 A1 1/2016 Stainvas Olshansky et al.
 2016/0018511 A1 1/2016 Nayyar et al.
 2016/0033631 A1 2/2016 Searcy et al.
 2016/0041260 A1 2/2016 Cao et al.
 2016/0061935 A1 3/2016 McCloskey et al.
 2016/0084941 A1 3/2016 Arage
 2016/0084943 A1 3/2016 Arage
 2016/0139254 A1 5/2016 Wittenberg
 2016/0154103 A1 6/2016 Moriuchi
 2016/0238694 A1 8/2016 Kishigami
 2017/0010361 A1 1/2017 Tanaka
 2017/0023661 A1 1/2017 Richert
 2017/0074980 A1 3/2017 Adib
 2017/0153316 A1 6/2017 Wintermantel

FOREIGN PATENT DOCUMENTS

EP 2821808 7/2015
 FR 2751086 1/1998
 WO WO2015175078 11/2015
 WO WO2015185058 12/2015
 WO WO2016011407 1/2016
 WO WO2016030656 3/2016
 WO WO2017175190 10/2017

OTHER PUBLICATIONS

Fraser, "Design and simulation of a coded sequence ground penetrating radar," In: Diss. University of British Columbia, Dec. 3, 2015.
 Zhou et al., "Linear extractors for extracting randomness from noisy sources," In: Information Theory Proceedings (ISIT), 2011 IEEE International Symposium on Oct. 3, 2011.
 International Search Report and Written Opinion dated Aug. 7, 2017 from corresponding PCT Application No. PCT/IB2017/052281.

* cited by examiner

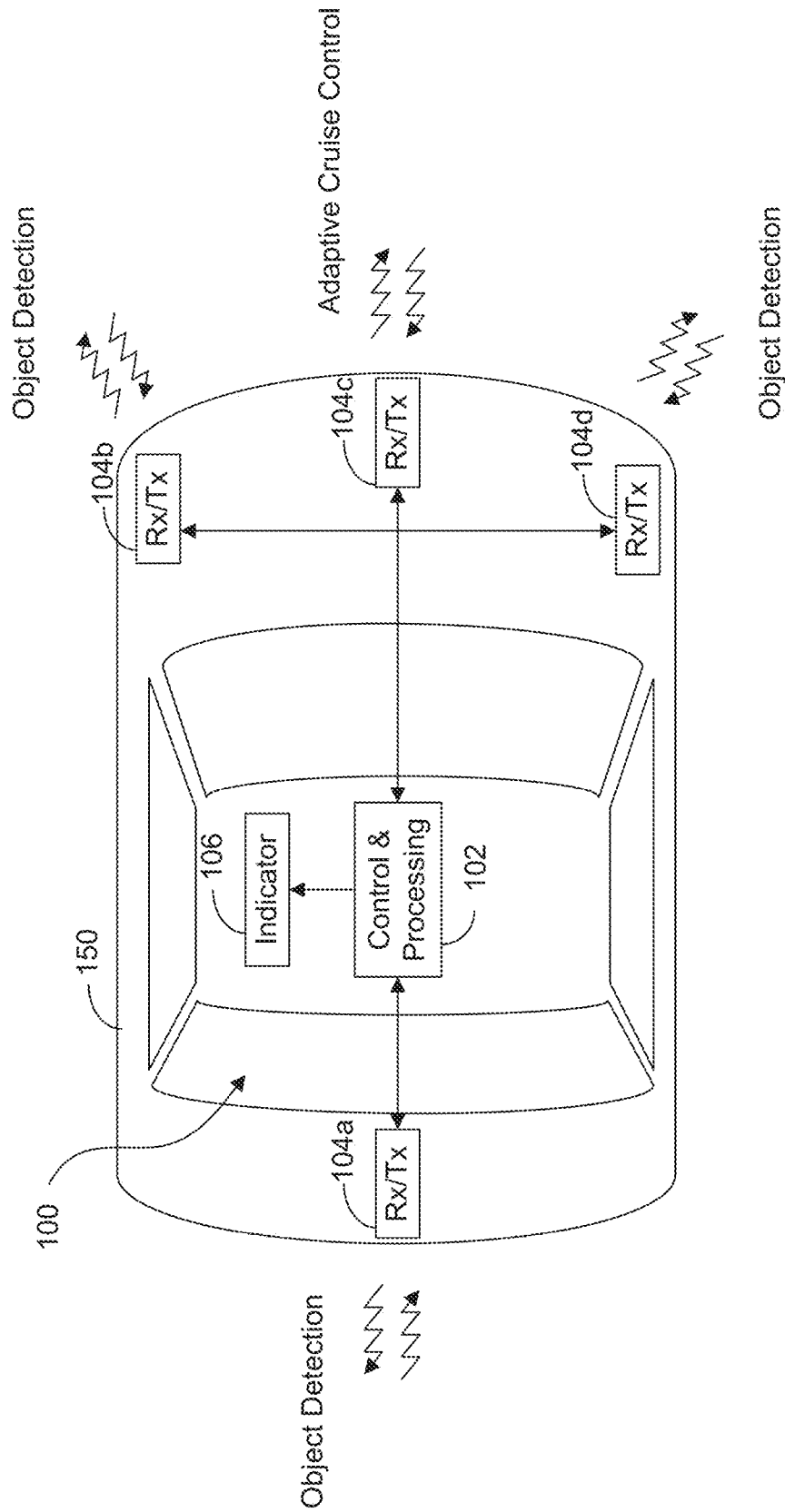

FIG. 1

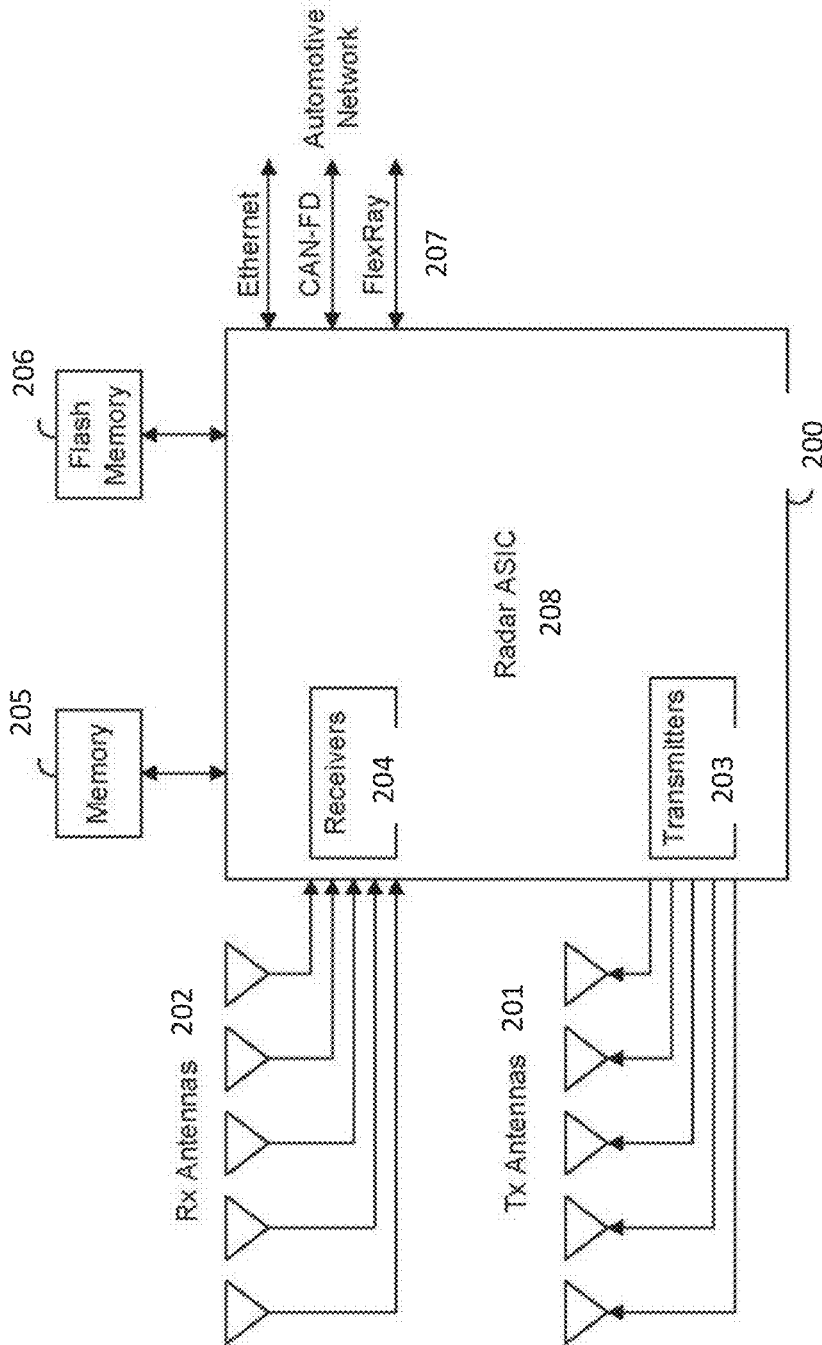
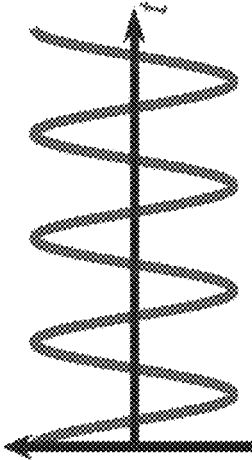
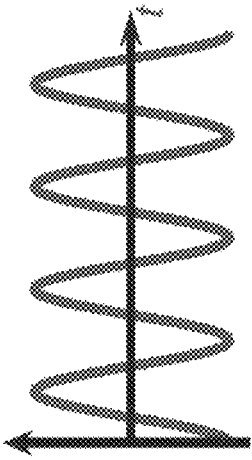

FIG. 2

Phase Modulated Signals



Phase 0 degrees



Phase 180 degrees

FIG. 3

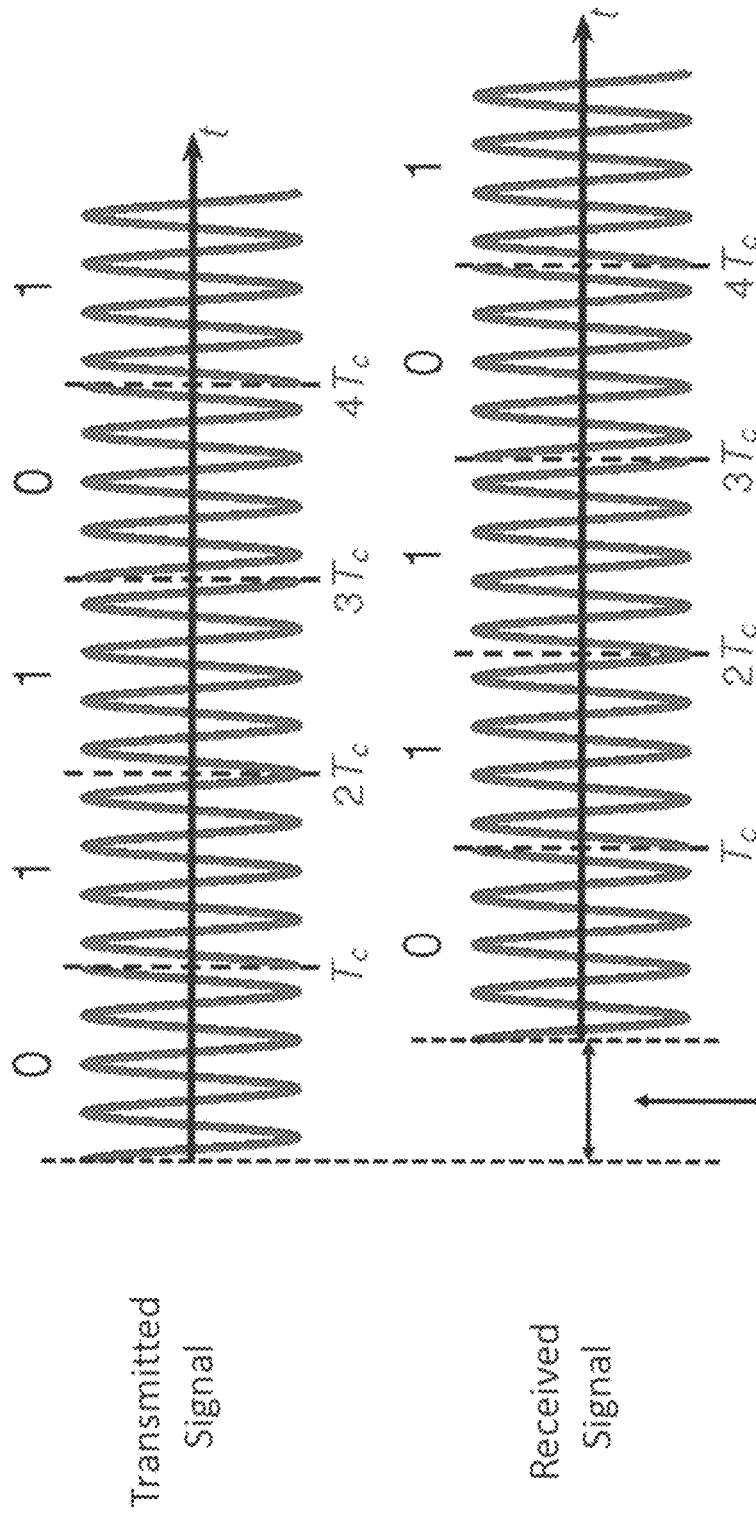

FIG. 4

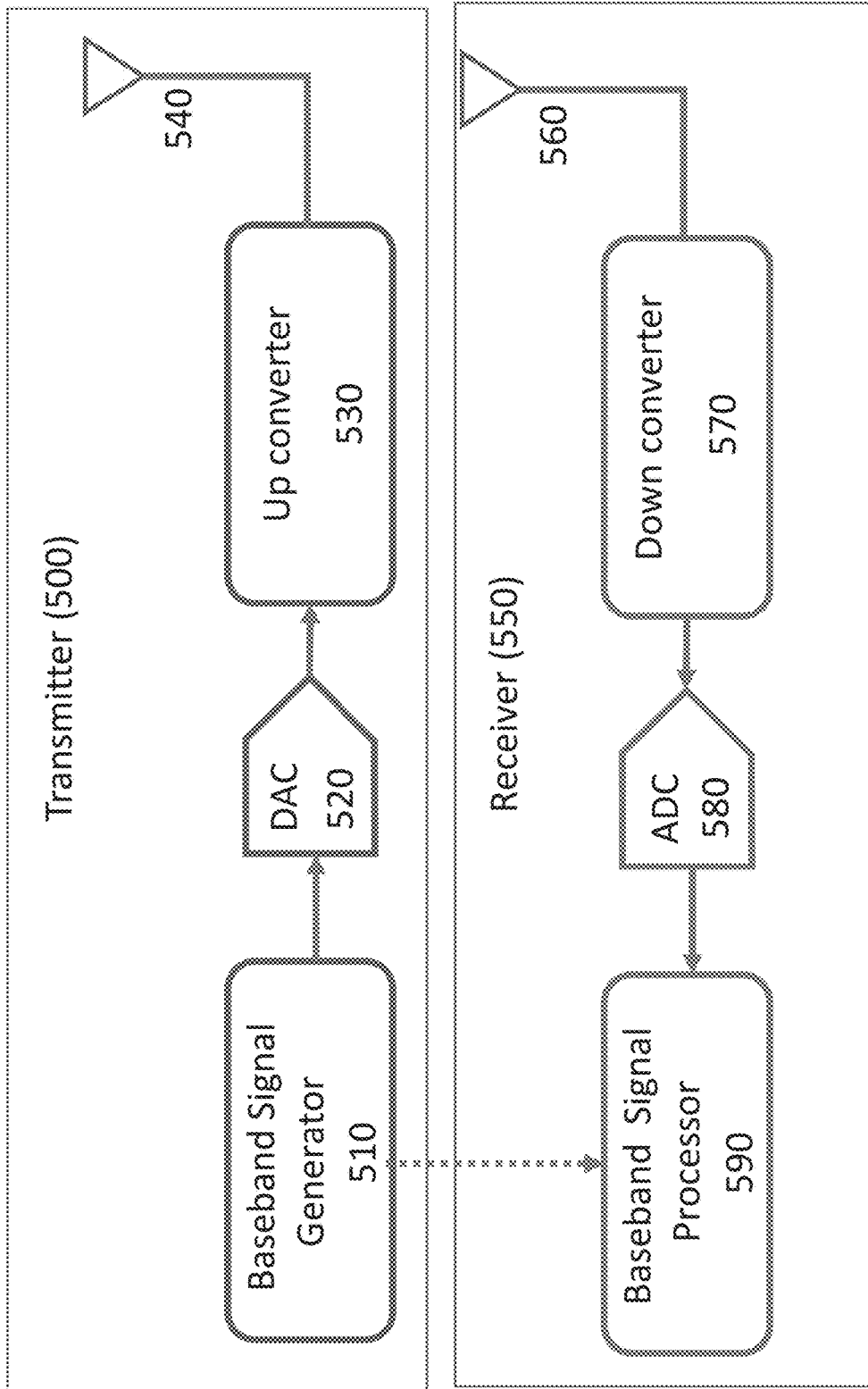

FIG. 5

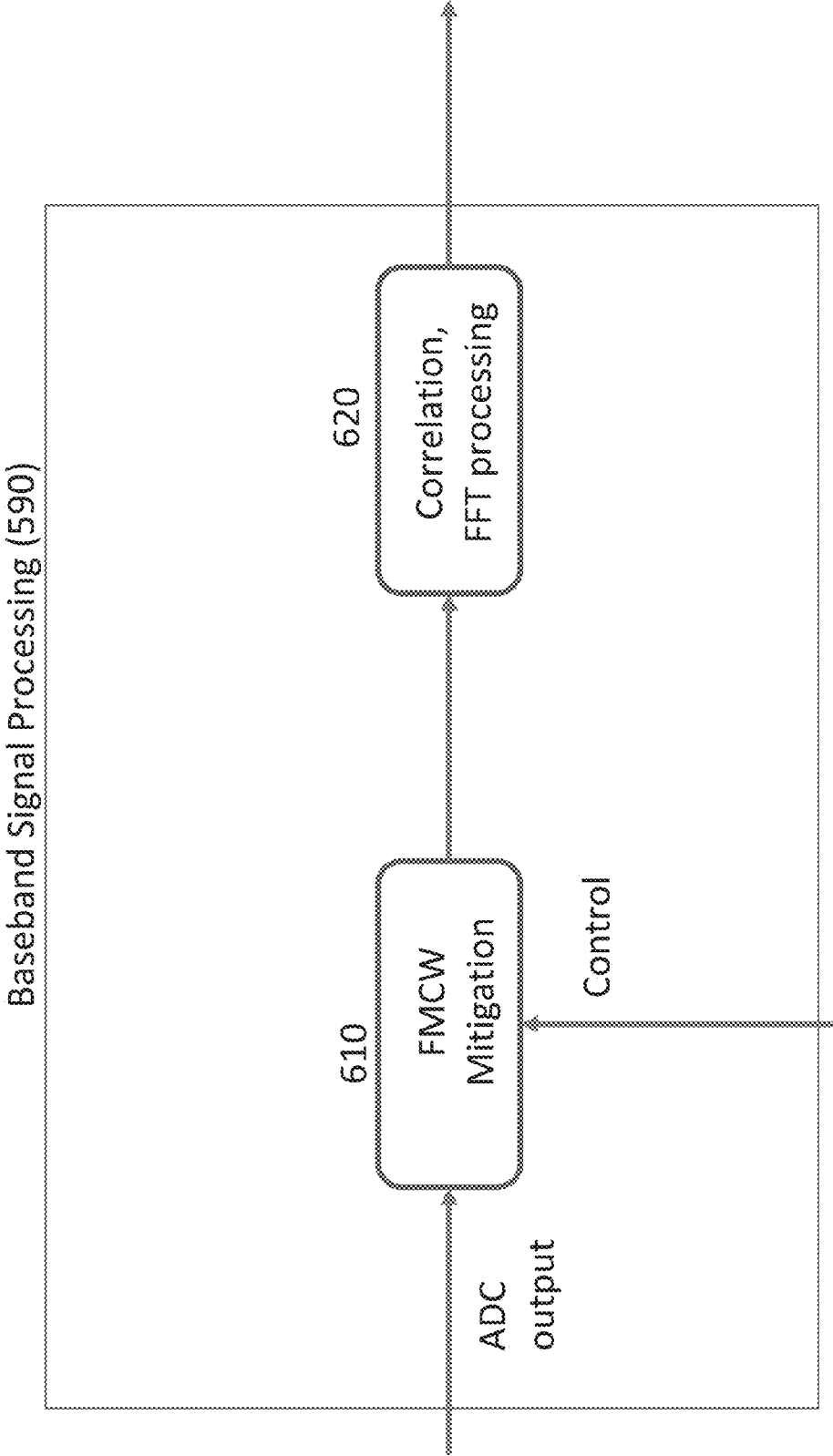

FIG. 6

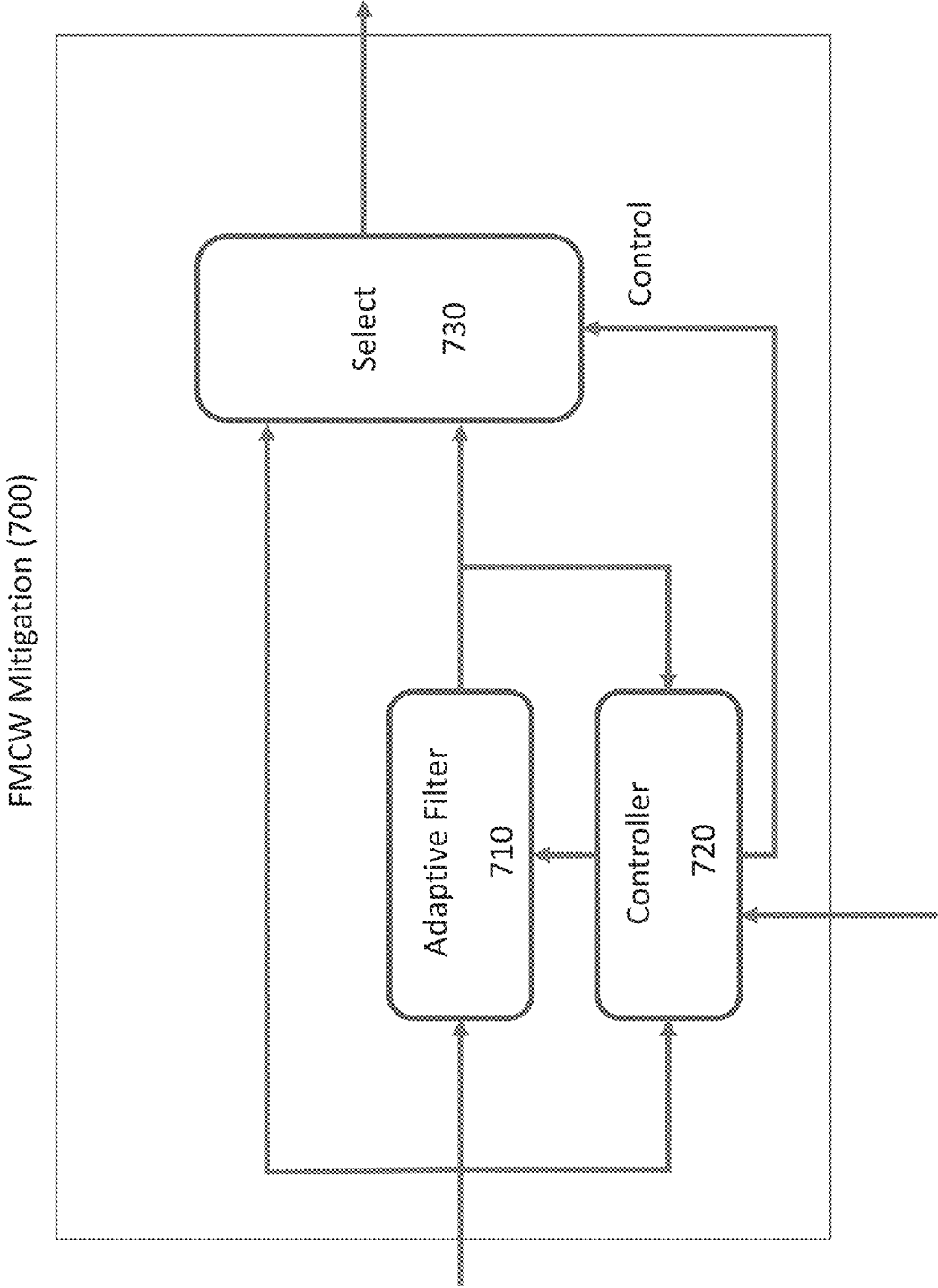

FIG. 7

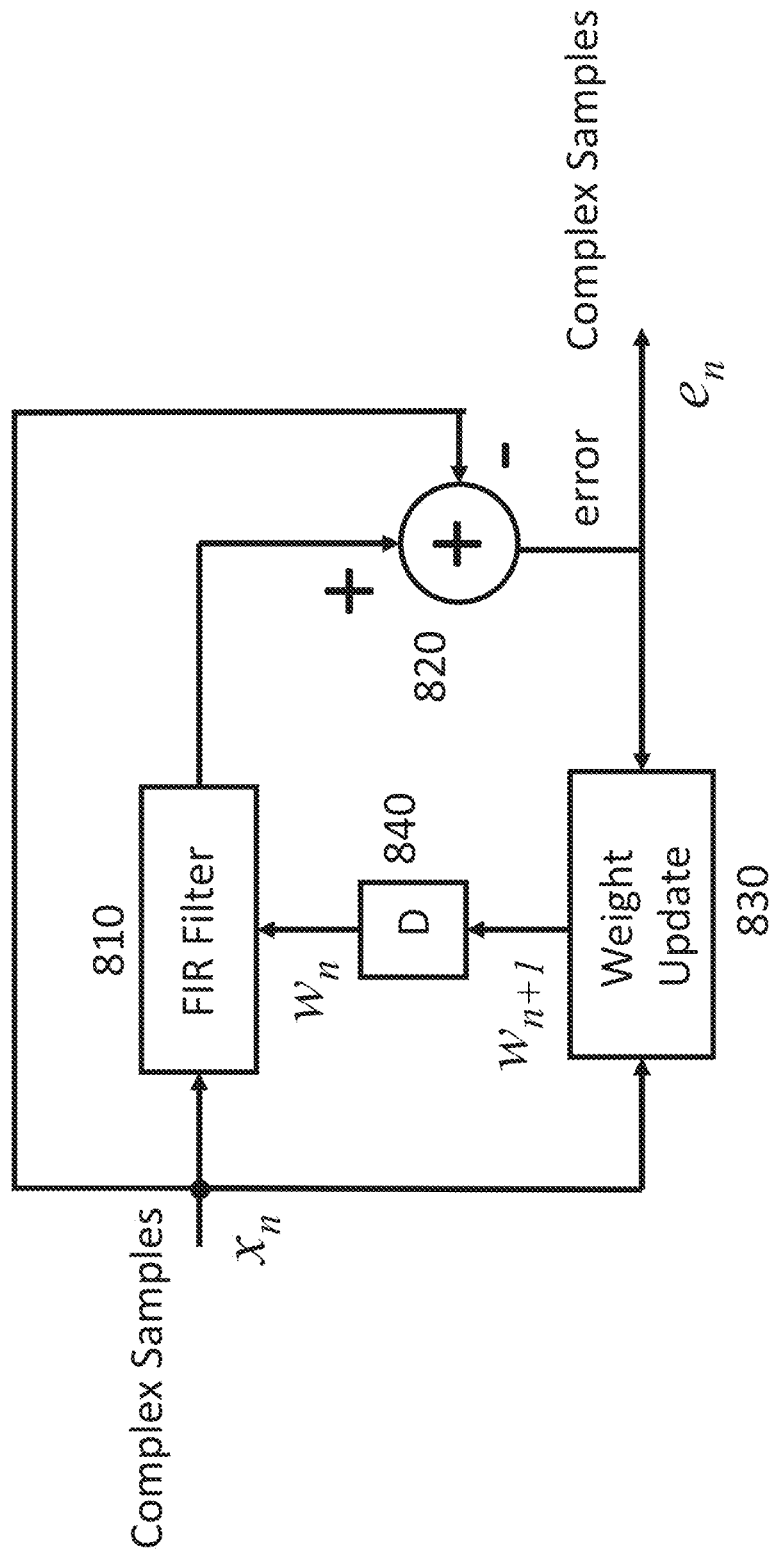

FIG. 8

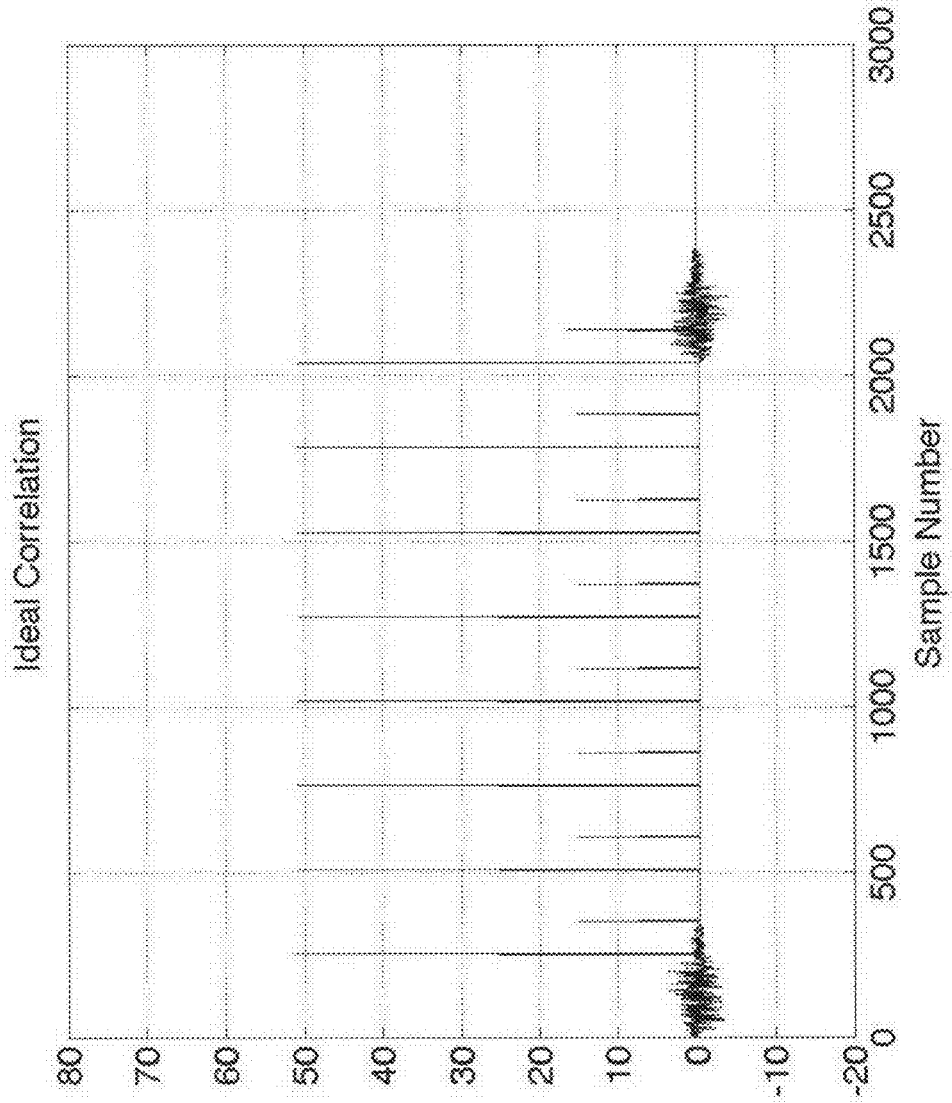

FIG. 9

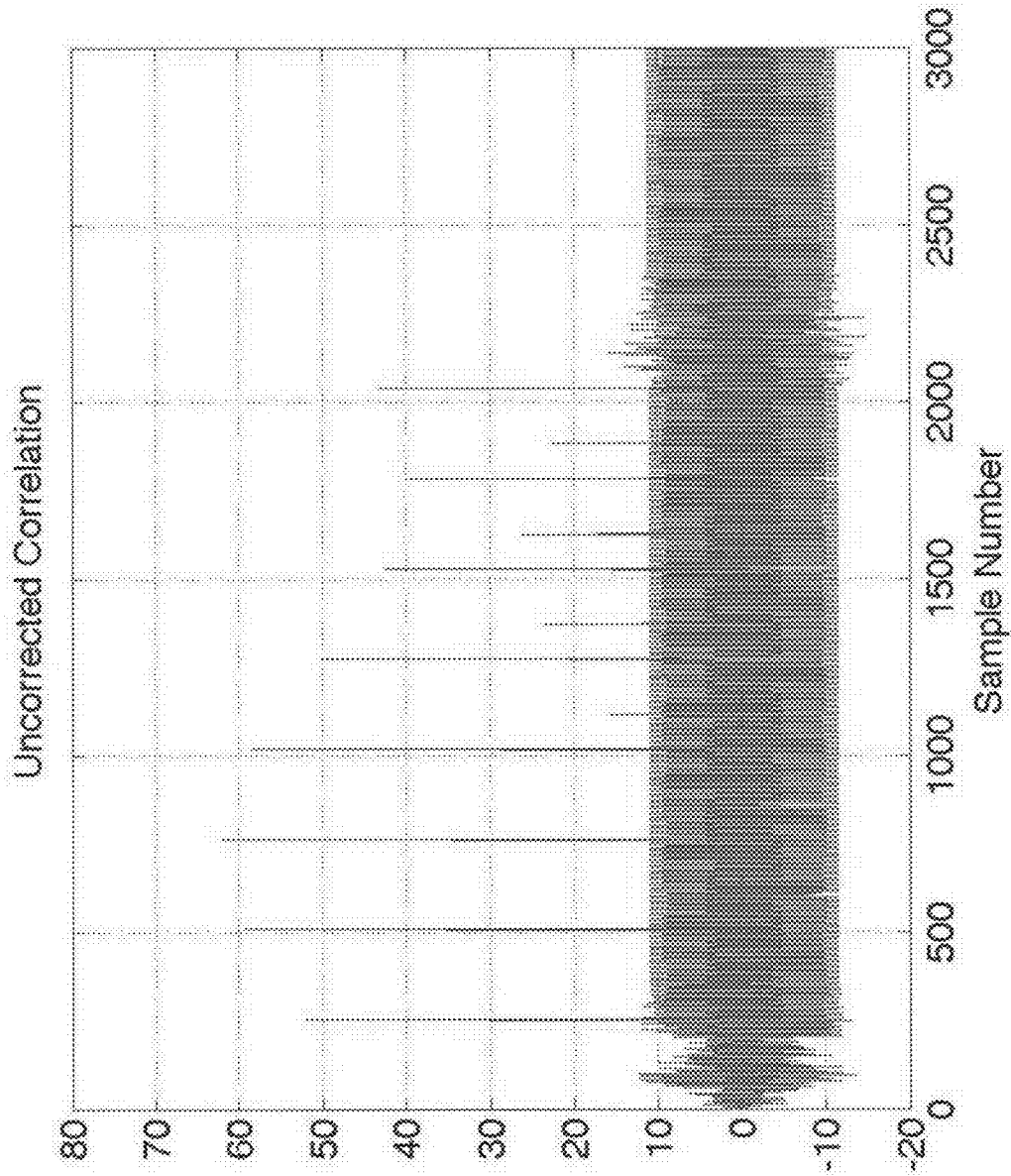

FIG. 10

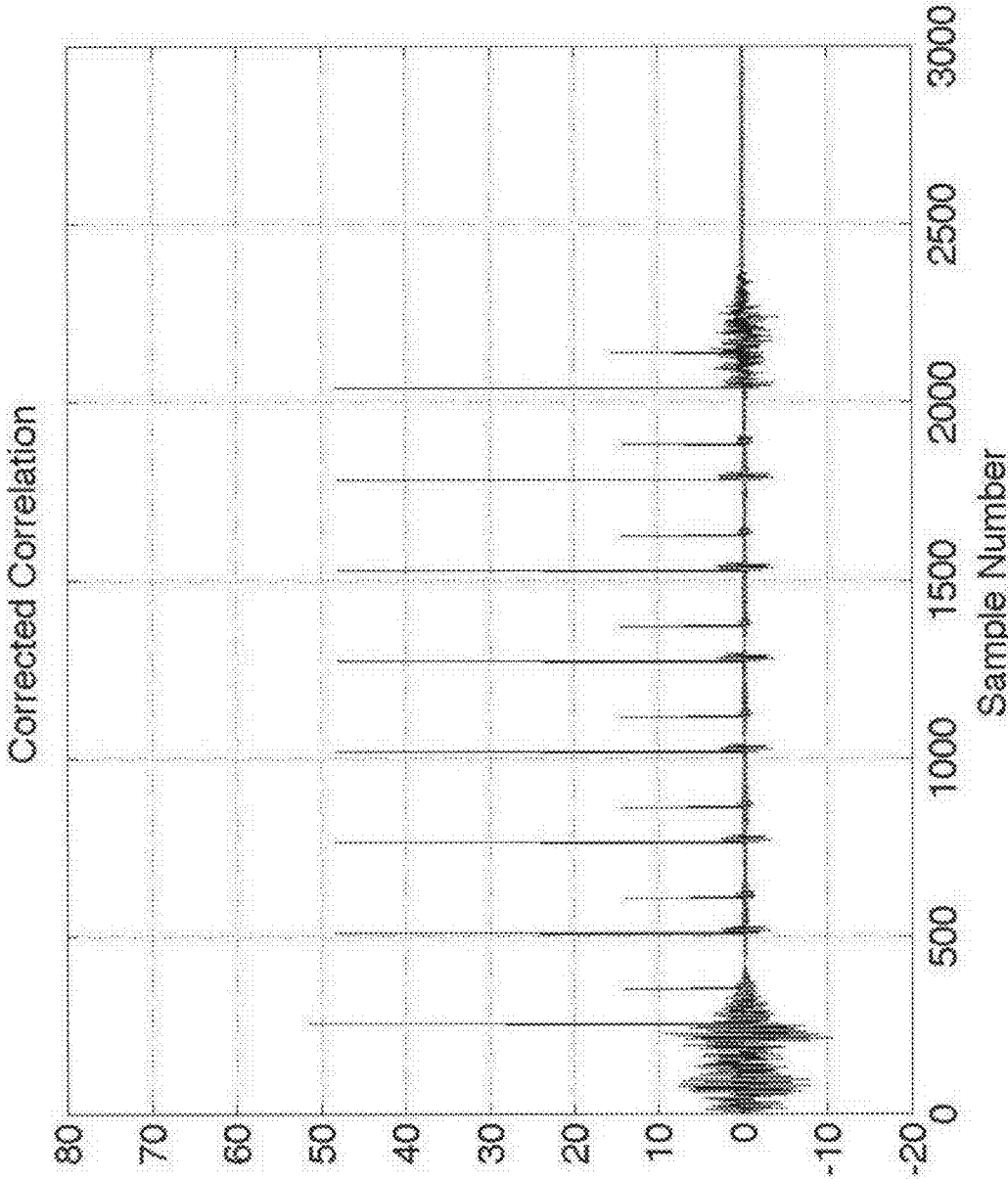

FIG. 11

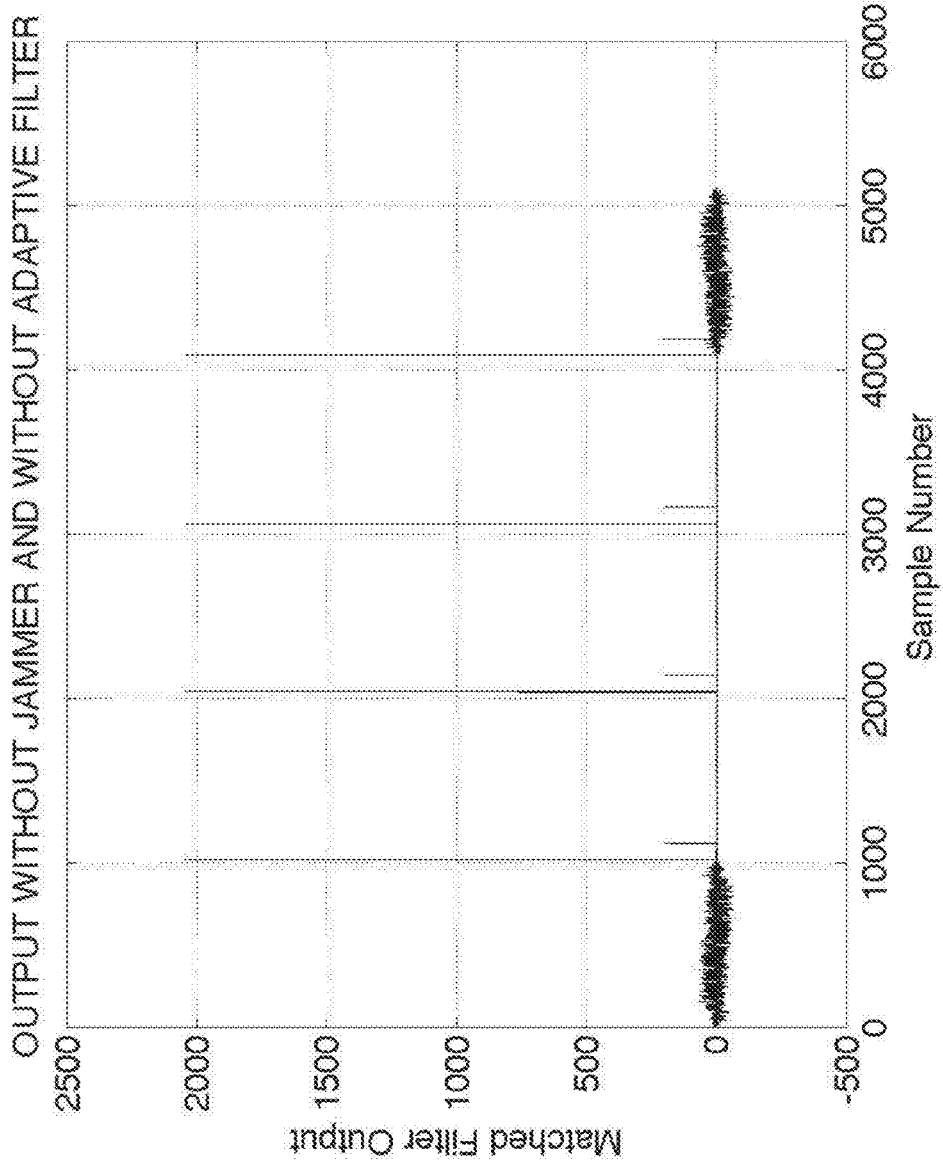

FIG. 12

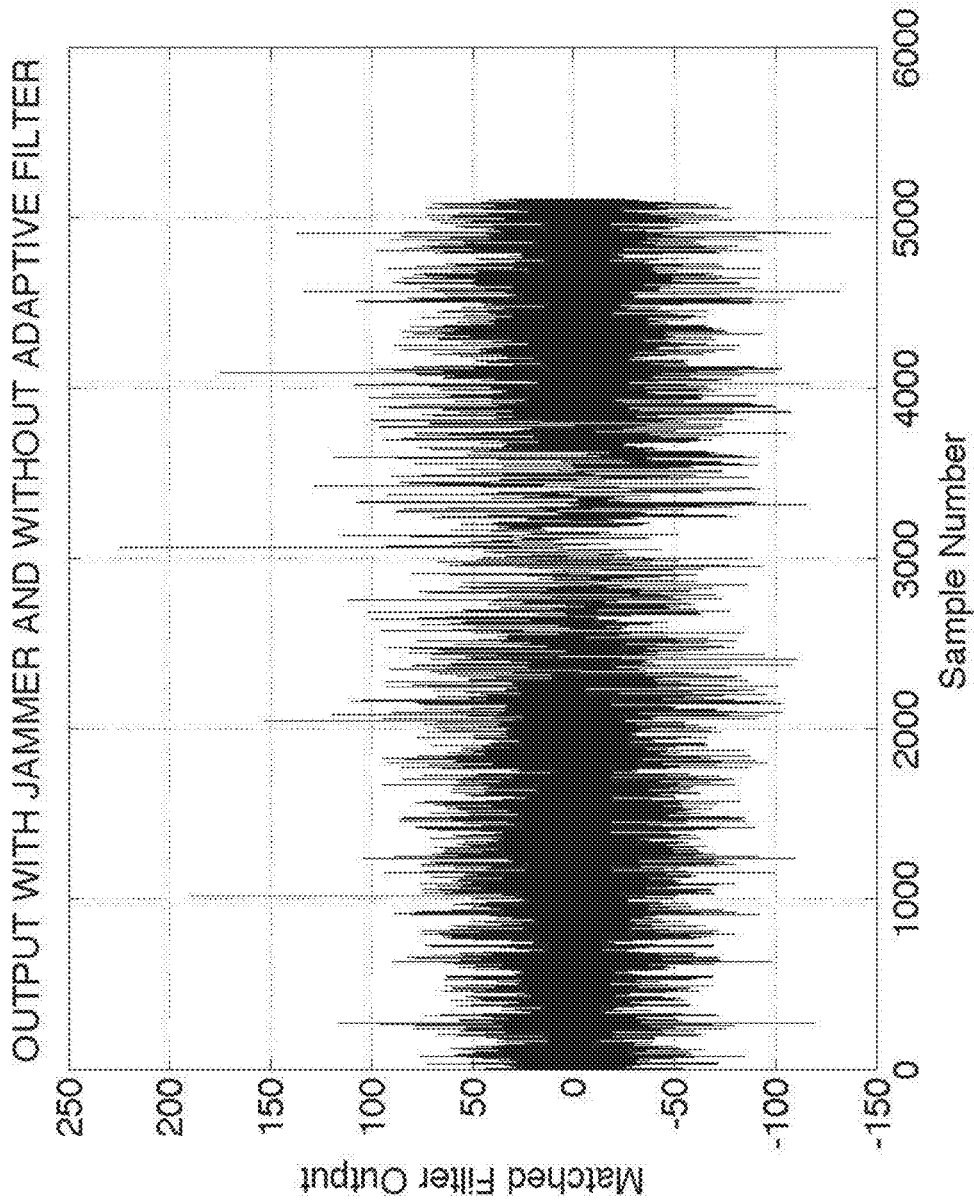

FIG. 13

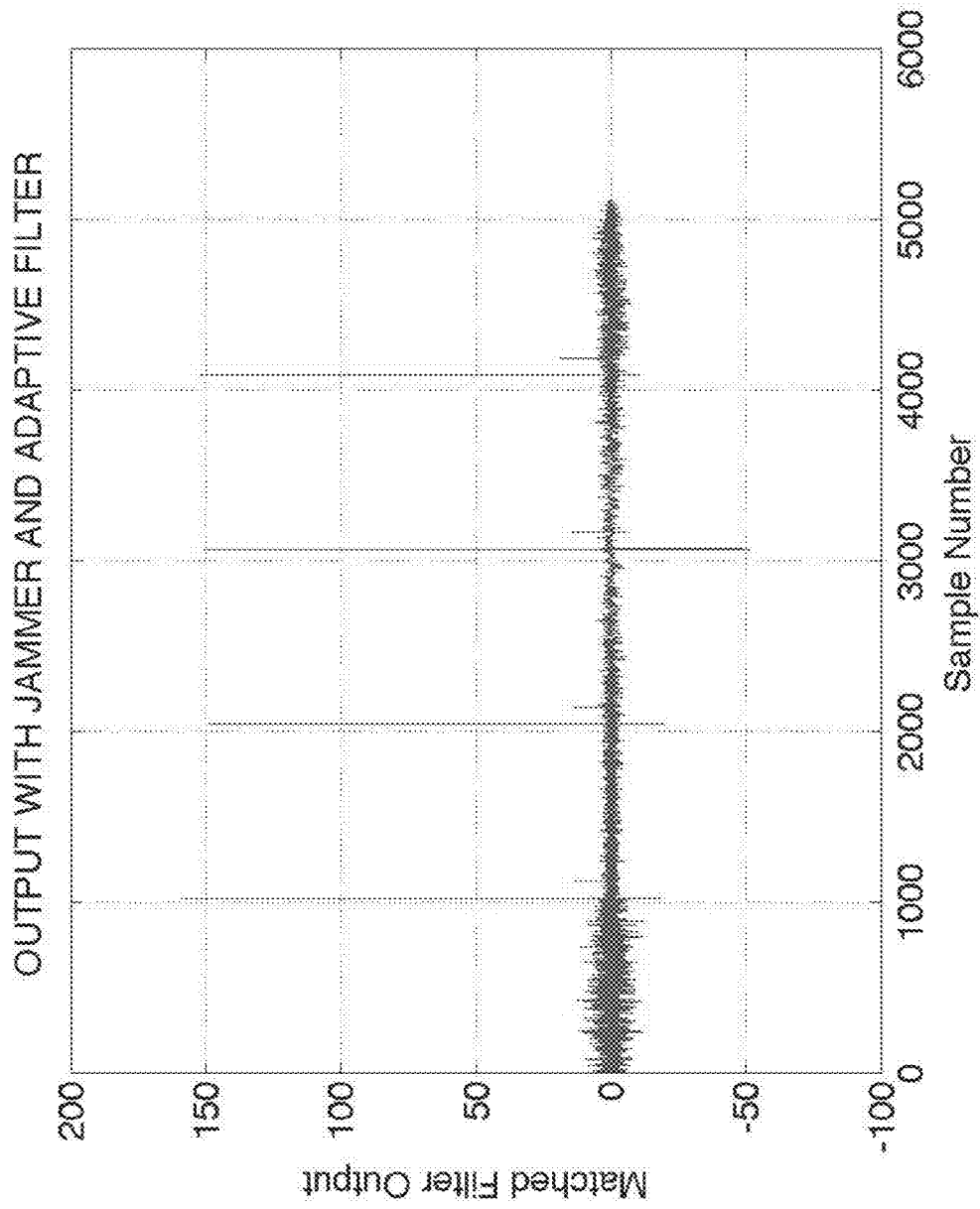

FIG. 14

1

ADAPTIVE FILTERING FOR FMCW INTERFERENCE MITIGATION IN PMCW RADAR SYSTEMS

CROSS REFERENCE TO RELATED APPLICATIONS

This application is a continuation of U.S. patent application Ser. No. 15/492,160, filed Apr. 20, 2017, now U.S. Pat. No. 9,791,564, which claims the filing benefits of U.S. provisional applications, Ser. No. 62/450,184, filed Jan. 25, 2017, and Ser. No. 62/327,005, filed Apr. 25, 2016, which are both hereby incorporated by reference herein in their entireties.

FIELD OF THE INVENTION

The present invention is directed to radar systems, and more particularly to radar systems for vehicles.

BACKGROUND OF THE INVENTION

The use of radar to determine range and velocity of objects in an environment is important in a number of applications including automotive radar and gesture detection. A radar system typically transmits radio signals and listens for the reflection of the radio signals from objects in the environment. By comparing the transmitted radio signals with the received radio signals, a radar system can determine the distance to an object. Using multiple transmissions, the velocity of an object can be determined. Using multiple transmitters and receivers, the location (angle) of an object can also be determined.

There are several types of signals used in different types of radar systems. One type of radar signal is known as a frequency-modulated continuous waveform (FMCW). In an FMCW radar system, the transmitter of the radar system sends a continuous signal in which the frequency of the signal varies. This is sometimes called a chirp radar system. Mixing (multiplying) the reflected wave from an object with a replica of the transmitted signal results in a CW signal with a frequency that represents the distance between the radar transmitter/receiver and the object. By sweeping up in frequency and then down in frequency, the Doppler frequency can also be determined.

Another type of radar signal is known as a phase-modulated continuous waveform (PMCW). For this type of radio signal, the phase of the transmitted signal is modulated according to a certain pattern or code, sometimes called the spreading code, known at the PMCW radar receiver. The transmitted signal is phase modulated by mixing a baseband signal (e.g., with two values +1 and -1) with a local oscillator to generate a transmitted signal with a phase that is changing corresponding to the baseband signal (e.g., +1 corresponding to a phase of 0 radians and -1 corresponding to a phase of π radians). For a single transmitter, a sequence of phase values that form the code or spreading code that has good autocorrelation properties is required so that ghost objects are minimized. The rate at which the phase is modulated determines the bandwidth of the transmitted signal and is called the chip rate.

In a PMCW radar system, the receiver performs correlations of the received signal with time-delayed versions of the transmitted signal and looks for peaks in the correlation. The time-delay of the transmitted signal that yields peaks in the correlation corresponds to the delay of the transmitted signal

2

when reflected off an object. The distance to the object is found from that delay and the speed of light.

A PMCW radar will receive not only the reflected signals from the transmitter of the PMCW radar. A PMCW radar operating in the presence of an FMCW radar will also receive the signals from the FMCW radar. The signal from the FMCW radar can significantly affect the performance of a conventional PMCW radar system. Potentially, these FMCW signals can be much stronger than the reflected signals from the PMCW radar. This may cause the radar system's estimated range, velocity and direction to be significantly in error.

SUMMARY OF THE INVENTION

The present invention provides methods and a system for achieving better performance in a radar system using phase-modulated continuous wave (PMCW) radar when there are one or more other radar systems using a frequency-modulated continuous wave (FMCW) type of radar transmission and operating simultaneously. The invention accomplishes better detectability of a PMCW radar object by applying a filtering technique to the received radio signal that mitigates the effect of an interfering FMCW radar on the PMCW radar. Another source of potential interference is clock harmonics. The same techniques that are described below for FMCW interference mitigation will also work on clock harmonics.

A radar sensing system for a vehicle in accordance with an embodiment of the present invention includes at least one transmitter, at least one receiver, a memory, and a processor. The at least one transmitter is configured for installation and use on a vehicle and further operable or configured to transmit a radio frequency (RF) signal. The at least one transmitter is further operable or configured to transmit an RF signal using a phase modulated signal. The transmitted RF signal is generated by up-converting a baseband signal. The at least one receiver is configured for installation and use on the vehicle and further operable or configured to receive an RF signal. The received RF signal includes the transmitted RF signal reflected from multiple objects in the environment and potentially radio signals from other radars such as a frequency modulated continuous wave (FMCW) radar transmitter. The received RF signal is down-converted and sampled. The sampled result is provided to a processor. The processor selectively applies an adaptive filter to the received RF signal to mitigate the effect of an interfering waveform from a radar transmitting an FMCW radio signal. After adaptively filtering the received RF signal, the radar performs correlations with various delayed versions of the baseband transmitted signal. The correlations are used to determine an improved range, velocity and angle of objects in the environment.

A radar sensing system for a vehicle in accordance with an embodiment of the present invention includes at least one transmitter, at least one receiver, a memory, and a processor. The at least one transmitter is configured for installation and use on a vehicle and transmits a radio frequency (RF) signal. The at least one transmitter phase modulates the transmitted RF signal using codes generated by at least one of a pseudo-random sequence generator and a truly random number generator. The at least one receiver is configured for installation and use on the vehicle and further operable or configured to receive an RF signal. The received RF signal includes the transmitted RF signal reflected from an object. In addition, the received RF signal may also include radio signals transmitted from one or more other radar systems,

3

for example an FMCW radar. A down-converted received RF signal is sampled and provided to a processor. The processor selectively and adaptively filters the sampled signal to mitigate the effect of the FMCW radar on the PMCW radar system and then estimates the range, velocity and angle of objects in the environment.

A radar sensing system for a vehicle in accordance with an embodiment of the present invention includes at least one transmitter, at least one receiver, a memory, and a processor. The at least one transmitter is configured for installation and use on a vehicle and transmits a radio frequency (RF) signal. The at least one receiver is configured for installation and use on the vehicle and further operable or configured to receive an RF signal containing signals reflected from the transmitted signal as well as signals from one or more other radar systems. The reflected RF signal is the transmitted RF signal reflected from objects in the environment of the radar system. The radio signals from one or more other radar systems may be from an FMCW type of radar. A down-converted received RF signal is sampled and provided to a processor. The processor selectively filters out the interference from the FMCW radar system in an adaptive manner.

The radar system may include in the receiver a mechanism for deciding when to employ the cancellation (filtering) processing. The decision could be based on measuring the root mean square value (i.e., magnitude) of both the input and the output of the adaptive filter. The decision to filter could also be based on additional information such as obtained from other receivers in the radar system.

These and other objects, advantages, purposes and features of the present invention will become apparent upon review of the following specification in conjunction with the drawings.

BRIEF DESCRIPTION OF THE DRAWINGS

FIG. 1 is a plan view of an automobile equipped with one or more radar systems in accordance with the present invention;

FIG. 2 is a block diagram illustrating a radar system with a plurality of receivers and a plurality of transmitters in accordance with the present invention;

FIGS. 3 and 4 illustrate aspects of how PMCW digital radar works;

FIG. 5 is a block diagram illustrating the basic processing blocks of a transmitter and receiver in a radar system in accordance with the present invention;

FIG. 6 is a block diagram illustrating an exemplary baseband signal processor in accordance with the present invention;

FIG. 7 is a block diagram illustrating an interference mitigation processor in accordance with the present invention;

FIG. 8 is a block diagram illustrating the adaptive filter of FIG. 7 in accordance with the present invention;

FIG. 9 is an exemplary plot of an output of a correlator without any external interference in the case of two objects in the environment in accordance with the present invention;

FIG. 10 is an exemplary plot of an output of a correlator with a fixed frequency external interferer without the adaptive mitigation processing in accordance with the present invention.

FIG. 11 is an exemplary plot of an output of a correlator with a fixed frequency external interferer with adaptive mitigation processing in accordance with the present invention.

4

FIG. 12 is an exemplary plot of an output of a correlator without any external interference in the case of two objects in the environment and spreading codes of length 1023 in accordance with the present invention;

FIG. 13 is an exemplary plot of an output of a correlator with a chirp type external interferer without the adaptive mitigation processing in accordance with the present invention; and

FIG. 14 is an exemplary plot of an output of a correlator with a chirp type external interferer with adaptive mitigation processing in accordance with the present invention.

DESCRIPTION OF THE PREFERRED EMBODIMENTS

The present invention will now be described with reference to the accompanying figures, wherein numbered elements in the following written description correspond to like-numbered elements in the figures. Methods and systems of the present invention may achieve better performance from a radar system in the presence of a simultaneously operating FMCW radar by applying an adaptive filter to the down-converted and sampled received RF signal at one or more of the receivers in a radar system. The adaptive filtering may be selectively applied based on a measurement of the interference as well by considering other factors or conditions.

A radar system utilizes one or more transmitters to transmit signals. These signals are reflected from objects (also known as targets) in the environment and received by one or more receivers of the radar system. A transmitter-receiver pair is called a virtual radar (or sometimes a virtual receiver).

The transmitted radio signal from each radar transmitter consists of a baseband transmitted signal, which is up-converted to an RF signal by an RF upconverter. The up-converted RF signal may be obtained by mixing the baseband transmitted signal with a local oscillator signal at a carrier frequency. The baseband transmitted signal used for transmission by one transmitter of the radar system might be phase modulated using a series of codes. These codes, for example, consist of repeated sequences of random or pseudo-random binary values for one transmitter, e.g., (-1, -1, -1, 1, 1, 1, -1, 1, 1, -1, 1, -1, 1), although any sequence, including non-binary sequences and non-periodic sequences could be used and different sequences could be used for phase modulating the outputs of different transmitters. Each value of the phase modulation code sequence is often called a chip. A chip would last a certain duration called the chip time. The inverse of the chip time is the chip rate. That is, the chip rate is the number of chips per second. In an exemplary aspect of the present invention, the sequences of random binary values may be provided by a truly random number generator. A truly random number generator is explained in more detail in U.S. Pat. No. 9,575,160, which is hereby incorporated by reference herein in its entirety. The random bit stream (with values +1 or -1) from the truly random number generator may be multiplied with an output of pseudorandom binary values from a pseudorandom number generator (PRNG).

The transmitted radio signals are reflected from objects in the environment and are received back at the radar receivers (or virtual receivers). Each object in the environment may reflect the transmitted radio signal. The received radio signal at the radar system would consist of the sum of the radio signals reflected from various objects (targets) in the environment. In addition, a second radar system operating in the

vicinity of the first radar system will generate a transmitted radio signal that may be received by the first radar system and interfere with the reflected radio signals from the first radar system. In other words, the first radar system would receive radio signals that include radio signals from transmitters of the first radar system that are reflected from objects in the environment, as well as radio signals transmitted by one or more other radar systems.

At the receiver (receive pipeline) of the radar system, the received radio signal is down-converted by typical amplification, filtering, and mixing with in-phase and quadrature-phase components of an oscillator. The output after down-conversion and sampling is a sequence of complex value digitized samples comprising a mathematical real component and a mathematical imaginary component that are provided to a processor. The baseband signals used at the transmitter and the reflected radio signals after down-conversion in the receiver are provided to correlators. The complex valued digitized samples at the output of the down-converter are correlated with various time-delayed replicas of the baseband transmitted signals for different receivers to produce complex correlation values over a certain duration. That is, a sequence of digitized samples that correspond to a certain time duration of the received signal are correlated with a time-delayed replica of the baseband transmitted signal. The process is repeated for subsequent samples, thus producing a sequence of complex correlation values for a given time-delay. This process is also performed for different transmitter/receiver pairs (virtual receivers).

A selected correlator that has a replica that is matched in delay to the time delay of the reflected radio signal from an object will produce a large magnitude complex correlator output. A single correlator will produce a sequence of correlator outputs that are large if the reflected signal has a delay that matches the delay of the replica of the baseband transmitted signal. If the velocity of the radar system is different from the velocity of the object causing the reflection, there will be a Doppler shift in the frequency of the reflected signal relative to the transmitted signal. A sequence of correlator outputs for one particular delay corresponding to an object moving in the environment will have complex values that rotate at a rate related to the Doppler shift. Using a sequence of correlator outputs (also referred to as a scan), the Doppler shift may be estimated, and thus the velocity of the object in the environment determined. The longer the sequence of correlator outputs used to estimate the Doppler frequency, the greater the accuracy and resolution of the estimation of the Doppler frequency, and thus the greater the accuracy in estimating the velocity of the object.

The correlation values for various time delays and various virtual radars are arranged in two-dimensional arrays known as time slices. A time slice is a two-dimensional array with one dimension corresponding to delay or range bin and the other dimension corresponding to the virtual radar (transmitter-receiver pair). The samples are placed into respective range bins of the two-dimensional array (as used herein, a range bin refers to a distance range corresponding to a particular time delay corresponding to the round-trip time of the radar signal from a transmitter, to the target/object, and back to the receiver). The virtual receivers of the radar system define one axis of the two-dimensional time slice and the range bins define the second axis of the two-dimensional time slice. Another new time slice comprising complex correlation values is generated every 2-30 microseconds. Over a longer time interval, herein referred to as a "scan" (typically, in a duration of 1-60 milliseconds or longer), multiple time slices are accumulated to form a three-dimen-

sional radar data cube. One axis or dimension of the three-dimensional radar data cube is defined by time (of each respective time slice requiring 2-30 microseconds), while the receivers (or virtual radar) define a second axis of the three-dimensional radar data cube, and the range bins and their corresponding time delays define a third axis of the three-dimensional radar data cube. A radar data cube may have a preselected or dynamically defined quantity of time slices. For example, a radar data cube may include 100 time slices or 1000 time slices of data. Similarly, a radar data cube may include different numbers of range bins. The optimized use of radar data cubes is described in detail in U.S. Pat. No. 9,599,702, which is hereby incorporated by reference herein in its entirety.

A single correlator output corresponding to a particular range bin (or delay) is a complex value that corresponds to the sum of products between a time-delayed replica of the baseband transmitted signal—with a time-delayed replica corresponding to each range bin—and the received down-converted complex samples. When a particular time-delayed replica in a particular range bin correlates highly with the received signal, it is an indication of the time delay (i.e., range of the object) for the transmitted radio signal that is received after the transmitted radio signal reflects from an object. Multiple correlators produce multiple complex correlation values corresponding to different range bins or delays. As discussed herein, each time slice contains one correlation value in a time series of correlation values upon which Doppler processing is performed (e.g., Fast Fourier Transform). In other words, a time series of complex correlation values for a given range bin is used to determine the Doppler frequency and thus the velocity of an object in the range bin. The larger the number of correlation values in the time series, the higher the Doppler resolution. A matched filter may also be used to produce a set of outputs that correspond to the correlator outputs for different delays.

There may be scans for different correlators that use replicas of the transmitted signal with different delays. Because there are multiple transmitters and multiple receivers, there may be correlators that process a received radio signal at each receiver that are matched to a particular transmitted radio signal by a particular transmitter. Each transmitter-receiver pair is called a "virtual radar" (a radar system preferably has 4 virtual radars, or more preferably 32 virtual radars, and most preferably 256 or more virtual radars). The receive pipeline of the radar system will thus generate a sequence of correlator outputs (time slices) for each possible delay and for each transmitter-receiver pair. This set of data is called a radar data cube (RDC). The delays are also called range bins. The part of the radar data cube for one point in the sequence of correlator outputs is called a time slice, and it contains one correlator output for each range bin and transmitter-receiver pair combination.

The complex-valued correlation values contained in a three-dimensional radar data cube may be processed, preferably by a processor established as a CMOS processor and coprocessor on a semiconductor substrate, which is typically a silicon substrate. In one embodiment, the processor comprises fixed function and programmable CPUs and/or programmable logic controls (PLCs). Preferably, the system will be established with a radar system architecture (including, for example, analog RF circuitry for the radar, processor(s) for radar processing, memory module(s), and other associated components of the radar system) all on a common semiconductor substrate. The system may preferably incorporate additional processing capabilities (such as, for example, image processing of image data captured by

one or more vehicle cameras such as by utilizing aspects of the systems described in U.S. Pat. Nos. 5,877,897; 5,796,094; 6,396,397; 6,690,268 and 5,550,677, which are hereby incorporated herein by reference in their entireties) within the same semiconductor substrate as well.

The ability of a continuous wave radar system to distinguish multiple targets is dependent upon the radar system's range, angle, and Doppler resolutions. Range resolution is limited by a radar's bandwidth (i.e., the chip rate in a phase modulated continuous wave radar), while angle resolution is limited by the size of the antenna array aperture. Meanwhile, increasing Doppler resolution only requires a longer scan. A high Doppler resolution is very valuable because no matter how close two objects or targets are to each other, as long as they have slightly differing radial velocity (their velocity towards or away from the radar system), they can be distinguished by a radar system with a sufficiently high enough Doppler resolution. As discussed herein, the detection of objects with a PMCW radar system may be adversely effected by the nearby operation of one or more frequency modulated continuous wave (FMCW) radar systems.

FIG. 1 illustrates an exemplary radar system **100** configured for use in a vehicle **150**. In an aspect of the present invention, a vehicle **150** may be an automobile, truck, or bus, etc. As illustrated in FIG. 1, the radar system **100** may comprise one or more transmitters and one or more receivers **104a-104d** for a plurality of virtual radars. Other configurations are also possible. As illustrated in FIG. 1, the radar system **100** may comprise one or more receivers/transmitters **104a-104d**, control and processing module **102** and indicator **106**. Other configurations are also possible. FIG. 1 illustrates the receivers/transmitters **104a-104d** placed to acquire and provide data for object detection and adaptive cruise control. The radar system **100** (providing such object detection and adaptive cruise control or the like) may be part of an Advanced Driver Assistance System (ADAS) for the automobile **150**.

FIG. 2 illustrates the structure of an exemplary radar system **200** containing one or more transmitting antennas **201**, one or more receiving antennas **202**, one or more transmitters **203**, one or more receivers **204**, memory modules **205**, **206**, as well as interfaces to other parts of a vehicle system via various types of networks **207**, such as Ethernet, CAN-FD, or FlexRay. There may also be processing capability contained in the ASIC **208** apart from the transmitters **203** and receivers **204**.

The radar sensing system of the present invention may utilize aspects of the radar systems described in U.S. Pat. Nos. 9,575,160 and/or 9,599,702, and/or U.S. patent application Ser. No. 15/416,219, filed Jan. 26, 2017, now U.S. Pat. No. 9,772,397, and/or Ser. No. 15/292,755, filed Oct. 13, 2016, now U.S. Pat. No. 9,753,121, and/or U.S. provisional applications, Ser. No. 62/382,857, filed Sep. 2, 2016, Ser. No. 62/381,808, filed Aug. 31, 2016, Ser. No. 62/327,003, filed Apr. 25, 2016, Ser. No. 62/327,004, filed Apr. 25, 2016, Ser. No. 62/327,006, filed Apr. 25, 2016, Ser. No. 62/327,015, filed Apr. 25, 2016, Ser. No. 62/327,016, filed Apr. 25, 2016, Ser. No. 62/327,017, filed Apr. 25, 2016, Ser. No. 62/327,018, filed Apr. 25, 2016, and/or Ser. No. 62/319,613, filed Apr. 7, 2016, which are all hereby incorporated by reference herein in their entireties.

FIG. 3 illustrates the basic waveforms of a PMCW radar. Depending on the baseband signal, one of two phases of a sinusoidal signal are generated. In a binary system, one of two phases of a sinusoidal signal are generated, typically 0 degrees and 180 degrees. This also corresponds to transmitting a signal or the opposite of that signal when the binary

baseband chip is a 0 or a 1. More than two phases could be used if the baseband signal is not binary.

The transmitted radio signal is then a sequence of sinusoidal signals with different phases as illustrated in FIG. 4. Each phase lasts T_c seconds, which is called the chip time. The inverse of the chip time is the chip rate, which is measured in chips per second. The chip rate might be on the order of 500 Mbps.

Also illustrated in FIG. 4 is the received radio signal that is due to a reflection of the transmitted radio signal from an object. The received radio signal (that includes the transmitted radio signal reflected from an object in the environment) will have the same basic shape as the transmitted radio signal but will be delayed by an amount corresponding to the round-trip time for the radio signal to propagate from the transmitter, to reflect from the object, and then back to be received by the receiver.

FIG. 5 illustrates an exemplary block diagram of a transmitter **500** in a radar system and an exemplary block diagram of a receiver **550** in the radar system. There may be more than one transmitter **500** and more than one receiver **550** in the radar system. A baseband signal is generated by a base band signal generator **510** which outputs digital signal samples that are used to form a baseband signal. These samples could be complex samples, representing the in-phase (I) and quadrature-phase (Q) baseband signals. These samples are used as the input to a digital-to-analog converter (DAC), represented as block **520**. The baseband analog signal at the output of the DAC is used as the input to the up-converter **530** which generates the RF signal for transmission through the transmit antenna **540**. The received radio signal from the receiver antenna **560** is down-converted in an exemplary down-converter module **570**, and sampled and quantized in an exemplary analog-to-digital converter (ADC) **580**. The down-converted signals might be complex (or a pair of real signals) representing the in-phase (I) and quadrature-phase (Q) of the RF signal. The output of the ADC **580** is processed by the baseband processing unit **590**. The baseband processing unit **590** will be aware of the baseband transmitted signal output from the baseband signal generator **510**. Optionally, the baseband signal generator **510** and the baseband signal processor **590** may be combined into a single processor **510/590**. There may be multiple baseband processing units **590** for a given ADC output that correspond to different transmitters (e.g., in a MIMO radar system, with multiple transmitters and multiple receivers). That is, for one receiver there may be a baseband processing unit that uses the baseband signal of a first transmitter and another baseband processing unit that uses the baseband signal of a second transmitter.

Aspects of the present invention are concerned with the baseband signal processing unit **590** of the receiver **550**. Because there may be signal interference from one or more radar systems of the FMCW-type, the output of the ADC **580** at the receiver **550** may include an interfering frequency-modulated radio signal in addition to the desired radio signal that has been generated by the PMCW radar system transmitter, reflected off of objects in the environment, and then received for processing by the receiver **550**. Mitigating interference from FMCW-type radar systems is the subject of this invention. In one aspect of the present invention, an adaptive filter is used to remove the interfering FMCW interference. However, it is possible that there are no waveforms from FMCW-type radar systems present (or that those waveform(s) are present, but below a threshold level), in which case there is no need to adaptively filter the received radio signal. As illustrated in FIG. 6, exemplary baseband

signal processor **590** includes an FMCW mitigation module **610**, followed by a correlation and FFT processing module **620** that provides further processing, such as a correlation to determine the range bin (distance) of an object, and an FFT to determine the velocity (or Doppler shift) of the object. An input to the FMCW mitigation module **610** is the output of the ADC **580**. The results of the baseband processing for one receiver are combined with other similar receivers to perform an angle-of-arrival estimation of an object. The baseband processing unit **590** of one receiver **550** may be combined with the baseband processing of other receivers **550**.

Baseband signal processor (**590**) will first adaptively filter the complex digitized sample with a least mean square (LMS) type of adaptive filter. An LMS filter is a well-known example of an adaptive filter that finds a difference between an input and an output, and using an error function and previous filter coefficients, determines updated filter coefficients. Exemplary LMS adaptation equations are illustrated below. The notation uses bold values for vectors. The vector w_n represents the vector of L tap weights. The vector x_n represents the last L inputs $x_n=(x_n, x_{n-1}, \dots, x_{n-L+1})$. The step size parameter is denoted as μ . A leakage coefficient α is chosen between 0 and 1.

$$w_{n+1}=\alpha w_n+\mu e_n x_n$$

$$e_n=x_n-y_n$$

$$y_n=w_n^T x_n$$

FIG. **8** illustrates an exemplary block diagram of an adaptive filter **710**. The adaptive filter of FIG. **8** includes a finite impulse response (FIR) filter **810** with L taps, an error calculator **820**, and a weight update calculator **830**. The FIR filter output is a correlation of the contents of a shift register with a weight vector w . The difference between the filter output and the input is an error signal. This is also the output of the mitigation filter. The error signal, the current input of complex samples, and the current set of weights used for the FIR filter, are used to update the set of weights of the FIR filter. In other words, the error signal is the output of the adaptive filter process. The eventual goal of the adaptive filter process will be to have removed much of the FMCW interference from the input of the filter.

The complex signal at the output of the interference mitigation filter will have reduced effect due to the interfering FMCW signal. As illustrated in FIG. **6**, this mitigation filter output is correlated with the spreading code corresponding to one or more desired transmitters. After adaptively filtering the received radio signal, correlations with various delayed versions of the transmitted baseband signal are performed in the correlation, FFT processing module **620**.

FIG. **9** illustrates an output of a matched filter when there are two objects in the environment but no other radar system operating. The exemplary transmitted radio signal is transmitting 8 periods of an m-sequence of length **255** with a chip rate of 500M chips/second. The received radio signal is down-converted, sampled, and used as the input to a matched filter where the filter is matched to one period of the m-sequence of length **255**. A matched filter is a method of correlating the received signal with all possible delays of the transmitted sequence. The output has 8 large spikes corresponding to a near object for each period of the m-sequence transmitted. FIG. **9** also illustrates that there are also 8 smaller amplitude spikes corresponding to a more distant target/object.

FIG. **10** illustrates an output of the same matched filter when, in addition to the two objects in the environment, there is a tone jammer with fixed frequency (which is similar to an FMCW radar system) that interferences with the reflected radio signals reflecting off of the objects. The output of the tone jammer, illustrated in FIG. **10** is used to simulate an interfering FMCW radar system. While the large spikes due to the radio signal reflecting off of the near object are still visible and detectable, the spikes due to the more distant object are sometimes lower than the signal due to the interference. Here, the interference is assumed to be 4 times (12 dB) larger than the desired signal from the nearer object.

FIG. **11** illustrates an output of the same matched filter when prior to performing the matched filtering, adaptive interference cancelling is done as described above. As illustrated in FIG. **11**, the adaptive filter effectively removes the undesired signal(s) and now signals reflected from both the nearby object and from the more distant object are clearly visible.

As another example, consider a radar system that transmits 4 periods of a spreading code of length **1023** with a chip rate of 500 Mchips/s. There are two objects in the environment. FIG. **12** illustrates an exemplary filter output when there is no signal interference (e.g., from an FMCW radar or equivalent) in the signal input and no adaptive filtering performed by the adaptive filter **710**. FIG. **13** illustrates an exemplary filter output when there is interference from another radar system, such as an FMCW radar that acts as a jammer. This FMCW radar transmits a chirp signal, which is a tone which varies in frequency. FIG. **13** further illustrates the effect of interference from an FMCW radar in the absence of any adaptive filtering. FIG. **13** also illustrates the output of a matched filter when the tone or chirp signal from the interfering FMCW radar has 20 dB larger amplitude than the desired return signals from the objects. As illustrated in FIG. **13**, the second object (the more distant object) becomes buried in the interfering FMCW radar signal. When an adaptive filter is employed, as described herein, the interference from the FMCW radar may be significantly reduced so that the radio signal reflected from the second, weaker object is visible. This is illustrated in FIG. **14**, where even when an input signal includes interference from an FMCW-type radar system, adaptive filtering has removed the majority of the interference so that the radio signal reflected from the second, weaker object is not buried in the interference.

In some cases, there is not another radar transmitting an FMCW-type of signal or the signal from an interfering FMCW-type radar is small in amplitude. In such a case, it is not useful to try to remove the nonexistent interference. As illustrated in FIG. **7**, a selection mechanism **730** and controller **720** may be used to bypass the adaptive filtering (as performed by the adaptive filter **710**). The selection mechanism **730** and controller **720** may also be referred to as a bypass mechanism. By default, the received radio signal bypasses the adaptive filter **710** without any cancellation/filtering. As illustrated in FIG. **7**, the input radio signal to the adaptive filter **710** is also received by the selection mechanism **730** and a controller **720**. To determine when to use the adaptive filter output and when to use the unfiltered input signal, a measurement of the root mean square (RMS) signal amplitude before and after cancellation/filtering may be performed by the controller **720** and a ratio of the RMS amplitude of the filter output to the RMS amplitude of the filter input is calculated. If the ratio is smaller than a selected threshold value, the adaptive filter's output, with the signal interference removed, is used. If the ratio is larger than the

11

selected threshold value, the output of the adaptive filter is not selected for use, instead, the unfiltered input signal is used.

By default, the switch 730 that determines whether to employ the adaptive filtering can be set by the controller 720 to pass the received complex samples without any filtering. While a filter output is generated by the adaptive filter 710, the unfiltered signal is selected by the switch 730, as controlled by the controller 720.

An alternative to this automatic determination of whether to employ or bypass the interference canceller, software can be used to decide whether to use the adaptive filter, where the decision is based not only on the RMS values or amplitude of the input and output but upon other information as well. The other information could include information provided by other receivers in the radar system.

The preferred embodiments work with a value of μ between 2^{-6} and 2^{-13} . The preferred leakage includes values from 2^{-8} to 2^{-15} . The number of taps may be changed depending on the situation. The values of the taps may be read and written from a processor executing software. Optionally, the taps may be frozen (unchanged) for some period of time.

In a preferred embodiment, only a single adaption filter is needed, even for multiple receivers. For example, there may be separate complex FIRs for each receiver that use a same set of coefficients. This is possible because the correction or filtering is phase-independent. The notch filtering of the FMCW tone works for all RX paths even though they may be phase-shifted relative to each other. This may save quite a bit of area in the implementation.

Changes and modifications in the specifically described embodiments can be carried out without departing from the principles of the present invention, which is intended to be limited only by the scope of the appended claims, as interpreted according to the principles of patent law including the doctrine of equivalents.

The invention claimed is:

1. A radar sensing system for a vehicle, the radar sensing system comprising:

a transmitter configured for installation and use on a vehicle, wherein the transmitter is configured to transmit a radio signal;

a receiver configured for installation and use on the vehicle, wherein the receiver is configured to receive radio signals that include (i) the transmitted radio signal reflected from objects in the environment, and (ii) other radio signals transmitted from at least one other radar sensing system;

a processor;

an adaptive filter;

wherein the receiver is further configured to sample the received radio signals to produce a sampled stream, and wherein the sampled stream is provided to the processor; and

wherein the processor, responsive to processing of the sampled stream, controls the adaptive filter to filter the sampled stream, such that the other radio signals transmitted from the at least one other radar sensing system are removed from the sampled stream.

2. The radar sensing system of claim 1, wherein the receiver is configured to produce the sampled stream by down-converting and sampling the received radio signals to produce the sampled stream.

3. The radar sensing system of claim 1, wherein the adaptive filter comprises a least mean square (LMS)-type of filter.

12

4. The radar sensing system of claim 3, wherein the LMS-type filter includes a finite impulse response filter.

5. The radar sensing system of claim 4 comprising a plurality of receivers, each with a finite impulse response (FIR) filter, wherein all of the FIR filters use a same set of weight values for processing the received signals.

6. The radar sensing system of claim 4, wherein a portion of filter coefficients for the adaptive filter are updated and another portion of the filter coefficients are held constant.

7. The radar sensing system of claim 6, wherein updated filter coefficients are determined based on an error function and previous filter coefficients of the adaptive filter.

8. The radar sensing system of claim 7, wherein the error function is based on a difference between an input to, and an output of, the adaptive filter.

9. The radar sensing system of claim 1 comprising a bypass mechanism configured to determine whether an output of the adaptive filter is to be selected or an input to the adaptive filter, which is the unfiltered sampled stream, is to be selected for further processing.

10. The radar sensing system of claim 9, wherein an output of the bypass mechanism is forwarded to a correlator and a fast Fourier transform (FFT) processing module for further processing.

11. The radar sensing system of claim 9, wherein the bypass mechanism is further configured to measure the amplitudes of the output of the adaptive filter and the input to the adaptive filter.

12. The radar sensing system of claim 9, wherein the bypass mechanism is configured to make a selection based at least in part on a root mean square (RMS) amplitude value of the input of the adaptive filter and an RMS amplitude value of the output of the adaptive filter.

13. The radar sensing system of claim 1, wherein unwanted interference is internal to the system.

14. The radar sensing system of claim 13, wherein the unwanted interference is due to clock harmonics.

15. The radar sensing system of claim 1, wherein the transmitter is configured to transmit a phase modulated radio signal, and wherein the at least one other radar system comprises at least one frequency modulated continuous wave radar system.

16. The radar sensing system of claim 1, wherein removing interference due to radio signals transmitted from at least one other radar system allows transmitted signals reflected from both a nearby object and a more distant object to be detectable by the receiver.

17. A method for removing interference from a radio signal received by a vehicle mounted radar sensing system, said method comprising:

providing a radar sensing system comprising a transmitter configured for installation and use on a vehicle and configured to transmit radio signals, and a receiver configured for installation and use on the vehicle and configured to receive radio signals that are the transmitted radio signals reflected from objects in the environment, and wherein the received radio signals further include other radio signals transmitted from at least one other radar system;

processing the received radio signals to produce a sampled stream;

adaptively filtering the sampled stream to produce a filtered sampled stream, such that the effect of the radio signals transmitted from the at least one other radar system are removed from the sampled stream; and performing range and velocity processing on the filtered sampled stream.

13

18. The method of claim 17, wherein processing the received radio signals comprises down-converting and digitizing the received radio signals to produce the sampled stream, wherein the sampled stream is a baseband sampled stream.

19. The method of claim 17, wherein performing range and velocity processing comprises performing correlation and fast Fourier transform (FFT) processing, respectively.

20. The method of claim 17, wherein adaptively filtering comprises filtering the sampled stream with a least mean square (LMS)-type of filter.

21. The method of claim 20, wherein the LMS-type filter comprises a finite impulse response filter.

22. The method of claim 17, wherein the transmitter is configured to transmit phase modulated radio signals, and wherein the at least one other radar system comprises at least one frequency modulated continuous wave radar system.

23. A radar sensing system for a vehicle, the radar sensing system comprising:

- a transmitter configured for installation and use on a vehicle, and further configured to transmit radio signals;
- a receiver configured for installation and use on the vehicle, and further configured to receive radio signals that include (i) the transmitted radio signals reflected from objects in the environment, and (ii) other radio signals transmitted from at least one other radar system;
- a processor;
- an adaptive filter;

14

wherein the receiver is further configured to sample the received radio signals to produce a sampled stream, and wherein the sampled stream is provided to the processor;

5 wherein the processor is configured to control the adaptive filter to adaptively filter the sampled stream, such that other radio signals transmitted from the at least one other radar sensing system are removed from the sampled stream; and

10 wherein the processor is configured to selectively control range and velocity processing on one of the filtered sampled stream and the sampled stream.

15 24. The radar sensing system of claim 23, wherein the stream selected for range and velocity processing is forwarded to a correlator and a fast Fourier transform (FFT) processing module.

25 25. The radar sensing system of claim 23, wherein the adaptive filter comprises a least mean square (LMS)-type of filter.

26. The radar sensing system of claim 25, wherein the LMS-type filter comprises a finite impulse response filter.

27. The radar sensing system of claim 23, wherein the transmitter is configured to transmit phase modulated radio signals, and wherein the at least one other radar system comprises at least one frequency modulated continuous wave radar system.

* * * * *