

(12) **United States Patent**  
**Goossen et al.**

(10) **Patent No.:** **US 8,375,837 B2**  
(45) **Date of Patent:** **Feb. 19, 2013**

(54) **CATCH AND SNARE SYSTEM FOR AN UNMANNED AERIAL VEHICLE**

(75) Inventors: **Emray R. Goossen**, Albuquerque, NM (US); **Steven D. Martinez**, Albuquerque, NM (US)

(73) Assignee: **Honeywell International Inc.**, Morristown, NJ (US)

(\* ) Notice: Subject to any disclaimer, the term of this patent is extended or adjusted under 35 U.S.C. 154(b) by 675 days.

(21) Appl. No.: **12/355,821**

(22) Filed: **Jan. 19, 2009**

(65) **Prior Publication Data**

US 2010/0181424 A1 Jul. 22, 2010

(51) **Int. Cl.**  
**B64D 1/00** (2006.01)

(52) **U.S. Cl.** ..... **89/1.11**; 244/110 F; 244/139

(58) **Field of Classification Search** ..... 244/110 C, 244/110 F, 139, 158.1; 89/1.11  
See application file for complete search history.

(56) **References Cited**

**U.S. PATENT DOCUMENTS**

4,196,668	A *	4/1980	Morlock et al.	102/473
4,202,279	A	5/1980	Rand	
4,442,018	A	4/1984	Rand	
4,768,417	A *	9/1988	Wright	89/1.11
5,150,857	A	9/1992	Moffitt et al.	
5,152,478	A	10/1992	Cycon et al.	
5,295,643	A	3/1994	Ebbert et al.	
5,467,682	A	11/1995	Brooks	
5,575,438	A	11/1996	McGonigle et al.	
5,583,311	A	12/1996	Rieger	
5,695,153	A	12/1997	Britton et al.	
5,898,125	A	4/1999	Mangolds et al.	

6,182,553	B1 *	2/2001	Peterson	89/1.11
6,450,445	B1	9/2002	Moller	
6,604,706	B1	8/2003	Bostan	
6,626,077	B1	9/2003	Gilbert	
6,691,949	B2	2/2004	Plump et al.	
6,721,646	B2	4/2004	Carroll	
6,854,374	B1 *	2/2005	Breazeale	86/50
6,904,838	B1	6/2005	Dindl	
6,957,602	B1	10/2005	Koenig et al.	
7,032,861	B2	4/2006	Sanders, Jr. et al.	
7,044,422	B2	5/2006	Bostan	
7,097,137	B2	8/2006	McDonnell	
7,201,348	B1	4/2007	Flammer	
7,249,732	B2	7/2007	Sanders, Jr. et al.	
7,264,204	B1	9/2007	Portmann	
7,328,644	B2	2/2008	Vickroy	
7,412,916	B2 *	8/2008	Lloyd	89/1.11

(Continued)

**FOREIGN PATENT DOCUMENTS**

EP	1767453	A1	3/2007
EP	1767453	B1	6/2008

(Continued)

*Primary Examiner* — Tien Dinh

*Assistant Examiner* — Michael Kreiner

(74) *Attorney, Agent, or Firm* — Shumaker & Sieffert, P.A.

(57) **ABSTRACT**

The present invention provides a catch and snare system for an unmanned aerial vehicle comprising: (a) a detection system, (b) a deployment system in communication with the detection system, (c) a capture system placed at an interference position by the deployment system, wherein the capture system comprises a net, a plurality of foam deploying canisters attached to the net for deploying foam, and at least one canister for deploying a decelerating parachute attached to the net, wherein the foam prevents the release of chemical or biological agents from the captured unmanned aerial vehicle, and (d) a descent system to bring the capture system and a captured unmanned aerial vehicle back to earth.

**20 Claims, 9 Drawing Sheets**

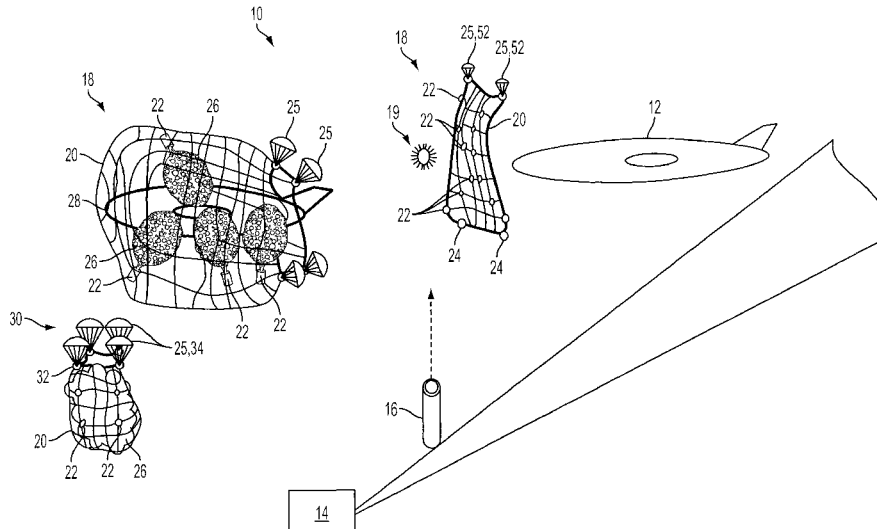

# US 8,375,837 B2

Page 2

## U.S. PATENT DOCUMENTS

7,415,917 B2\* 8/2008 Lloyd ..... 102/473  
7,900,548 B2\* 3/2011 Hoadley et al. .... 89/36.17  
2004/0094662 A1 5/2004 Sanders, Jr. et al.  
2004/0129828 A1 7/2004 Bostan  
2005/0082421 A1 4/2005 Perlo et al.  
2006/0049304 A1 3/2006 Sanders, Jr. et al.  
2006/0192047 A1 8/2006 Goossen  
2006/0231675 A1 10/2006 Bostan  
2007/0034738 A1 2/2007 Sanders, Jr. et al.  
2007/0051848 A1 3/2007 Mantych et al.  
2007/0193650 A1 8/2007 Annati

2007/0221790 A1 9/2007 Goossen et al.  
2007/0228214 A1 10/2007 Horak  
2007/0244608 A1 10/2007 Rath et al.  
2007/0261542 A1\* 11/2007 Chang et al. .... 89/1.11  
2007/0262195 A1 11/2007 Bulaga et al.  
2007/0295298 A1 12/2007 Mark

## FOREIGN PATENT DOCUMENTS

WO 0015497 3/2000  
WO 2004002821 1/2004

\* cited by examiner

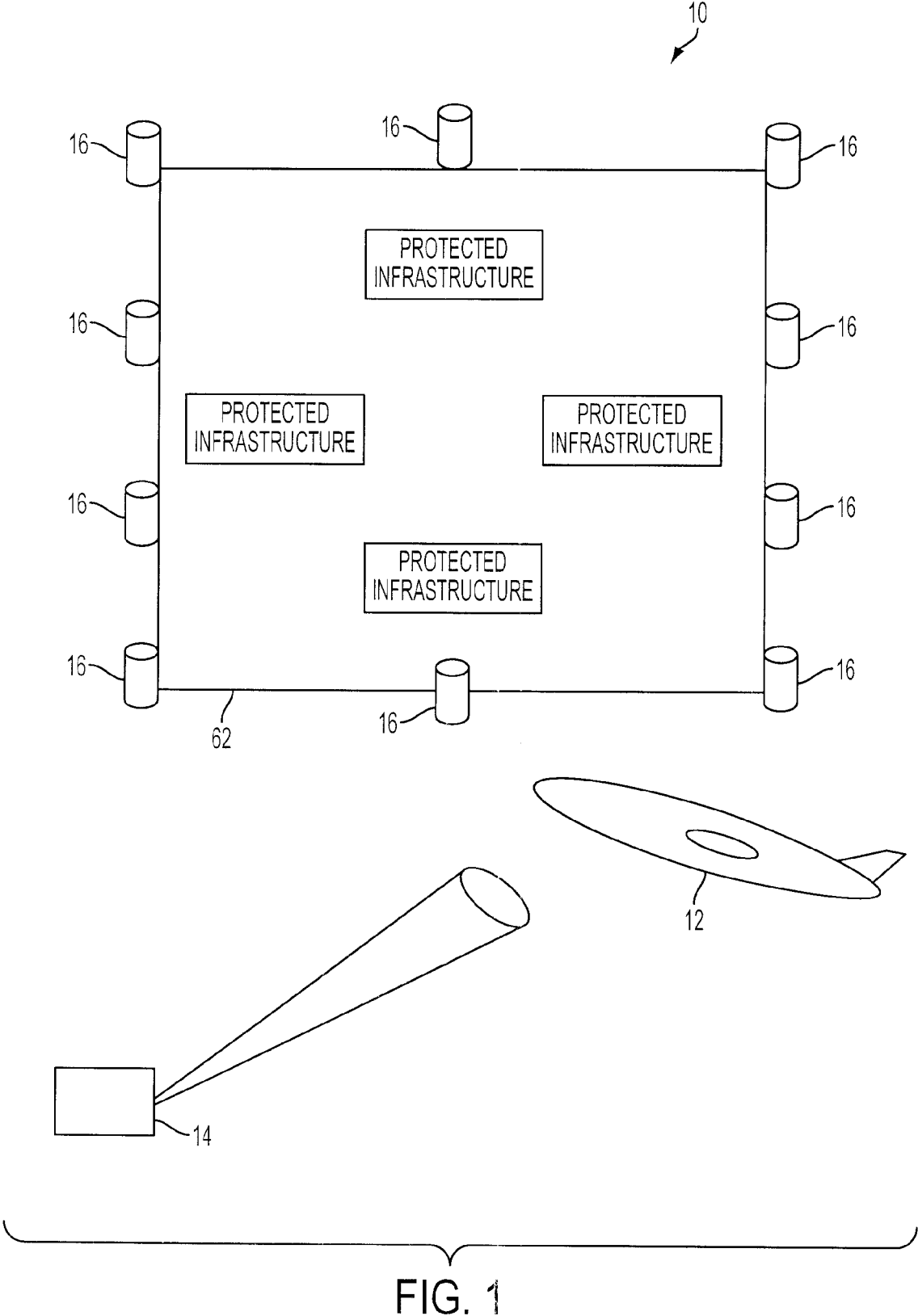

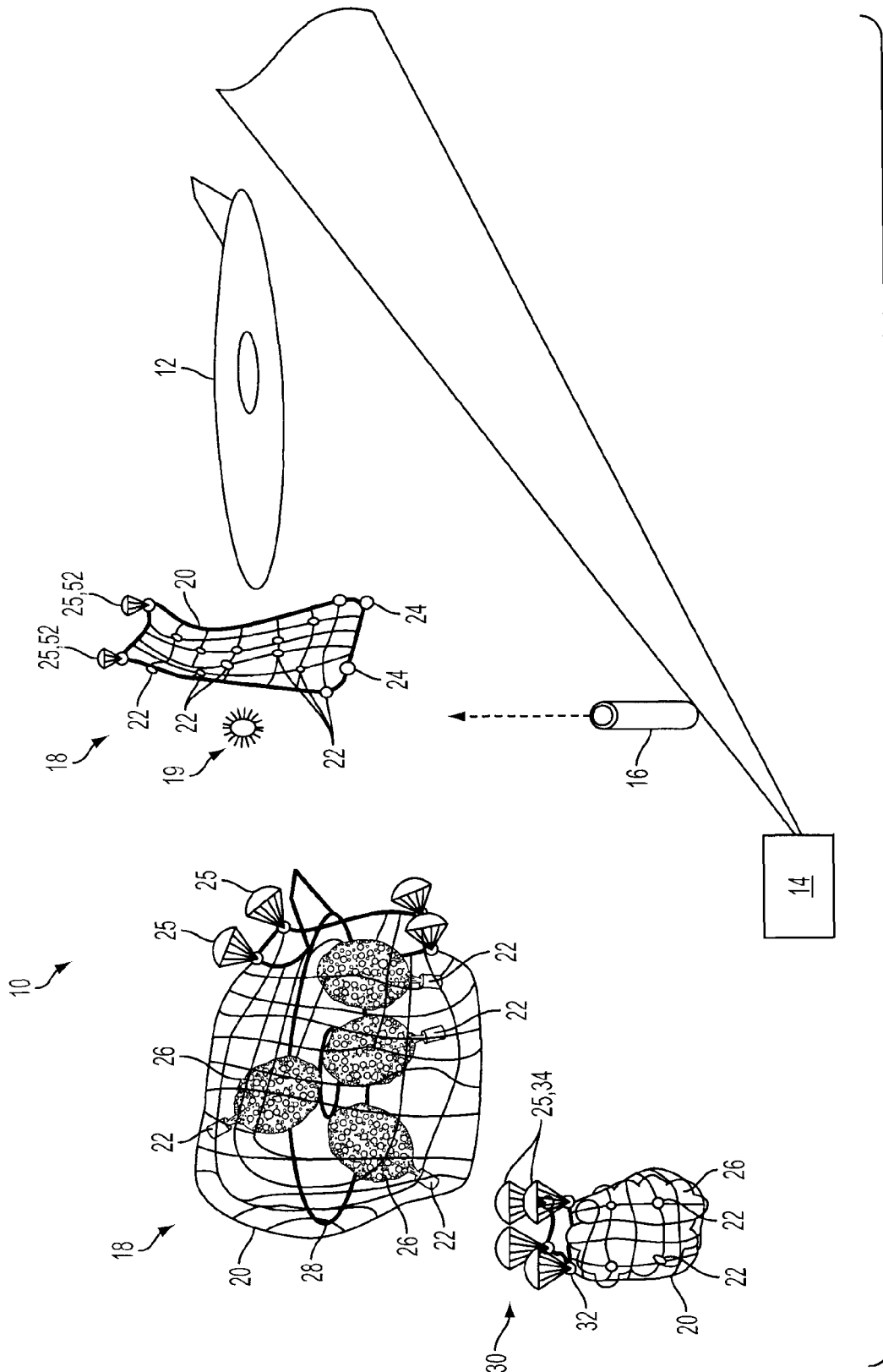

FIG. 2

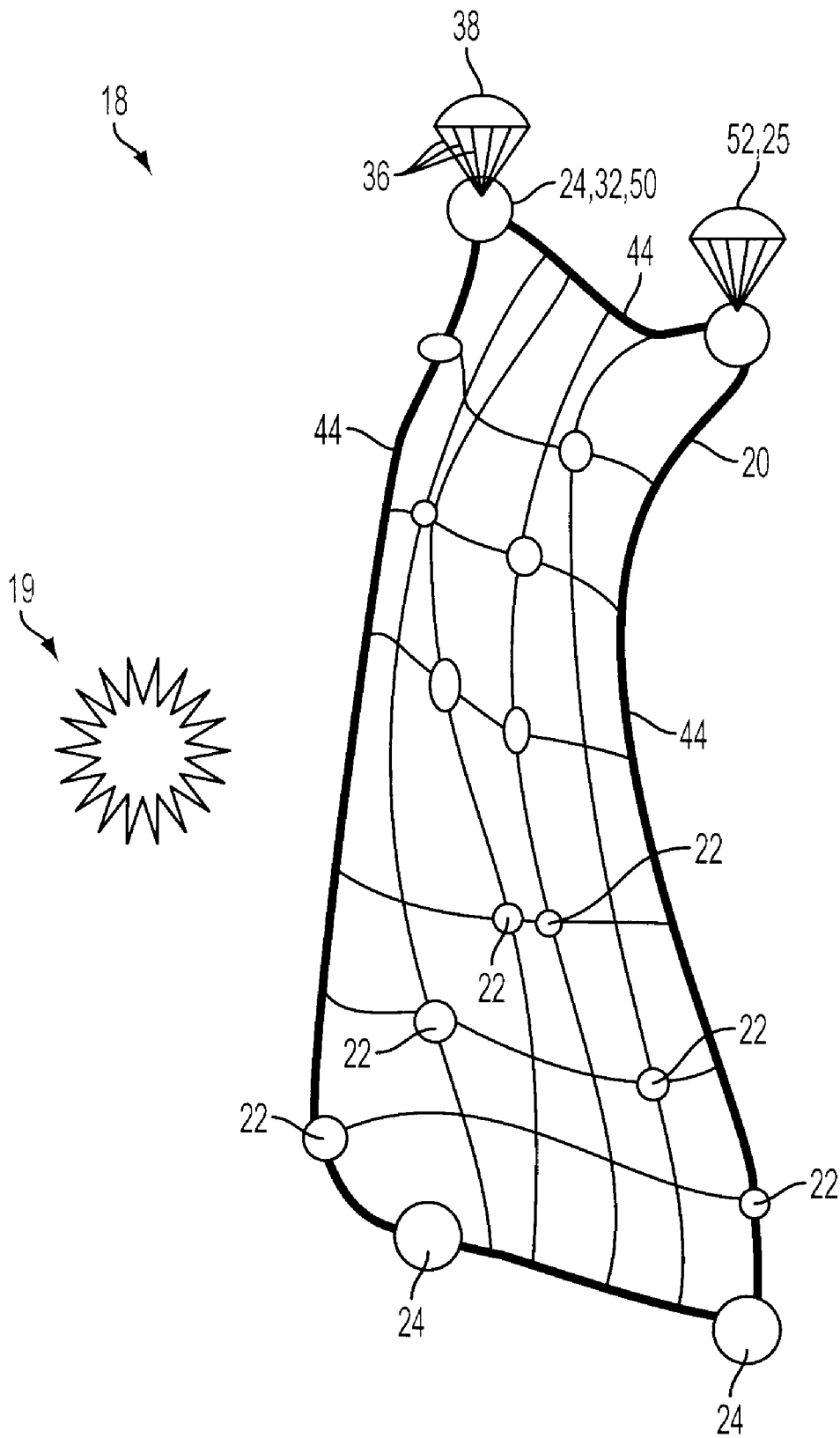

FIG. 3

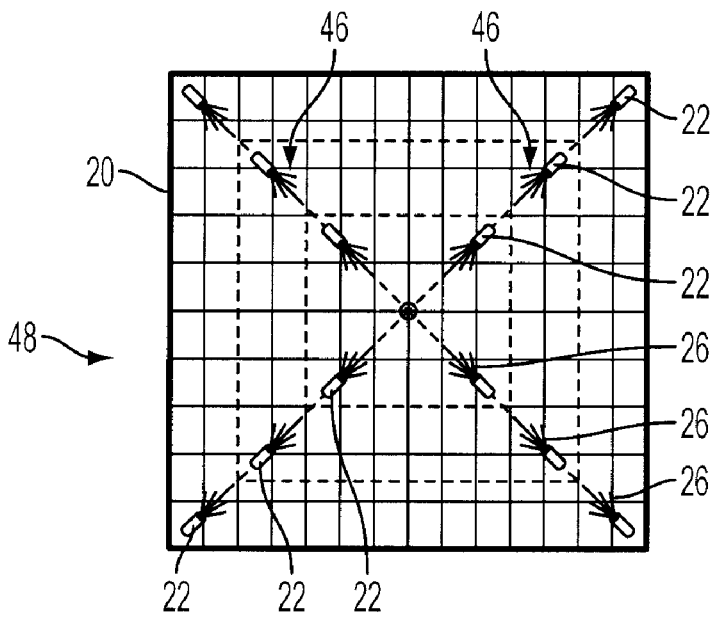

FIG. 4

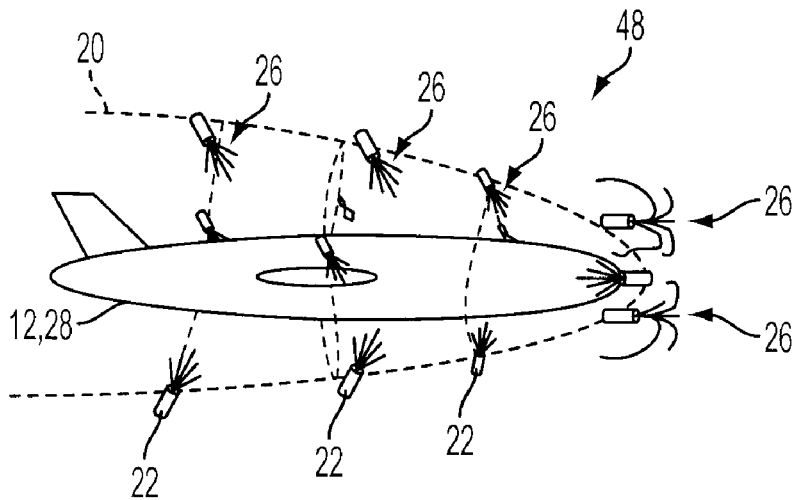

FIG. 5

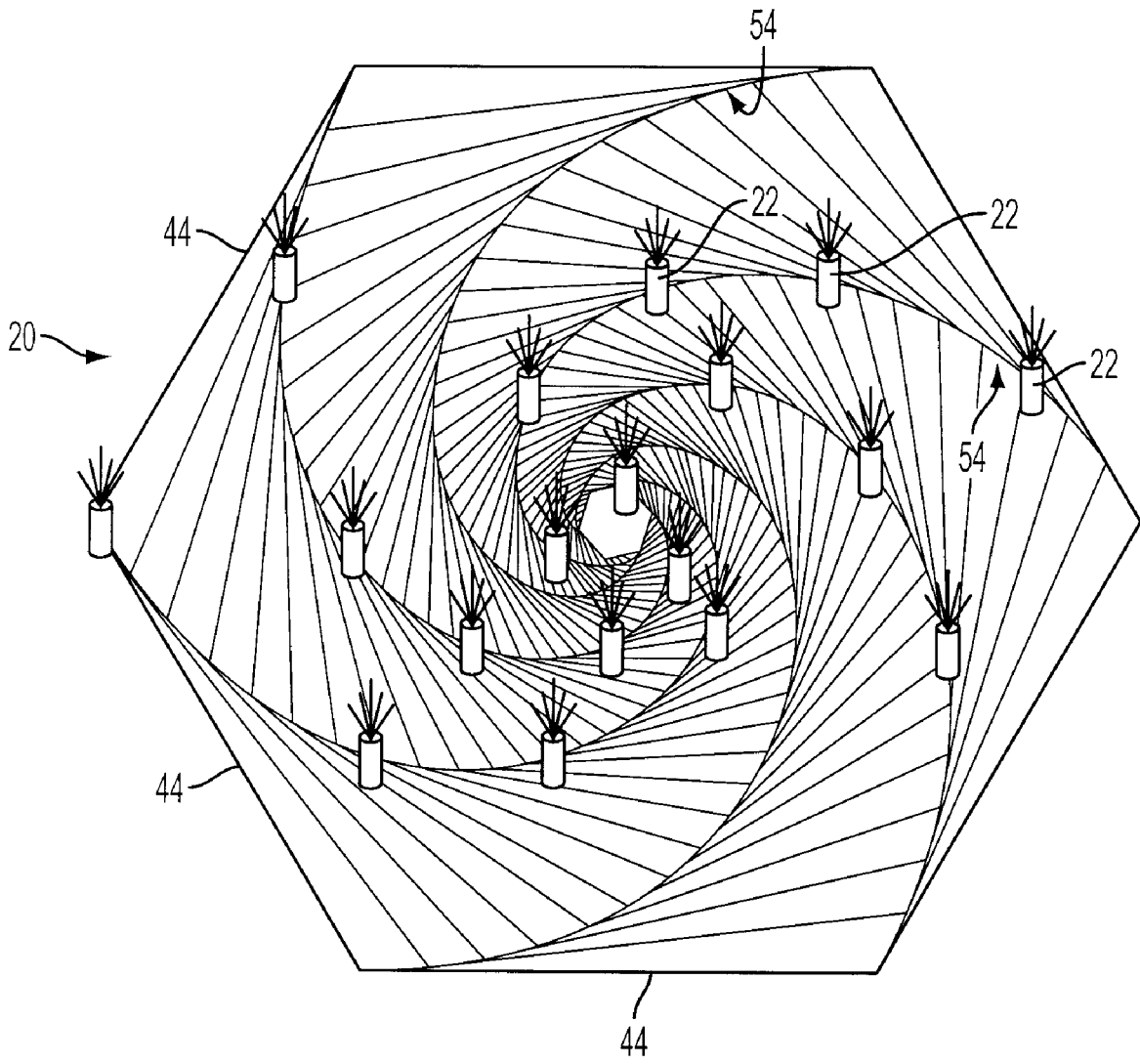

FIG. 6

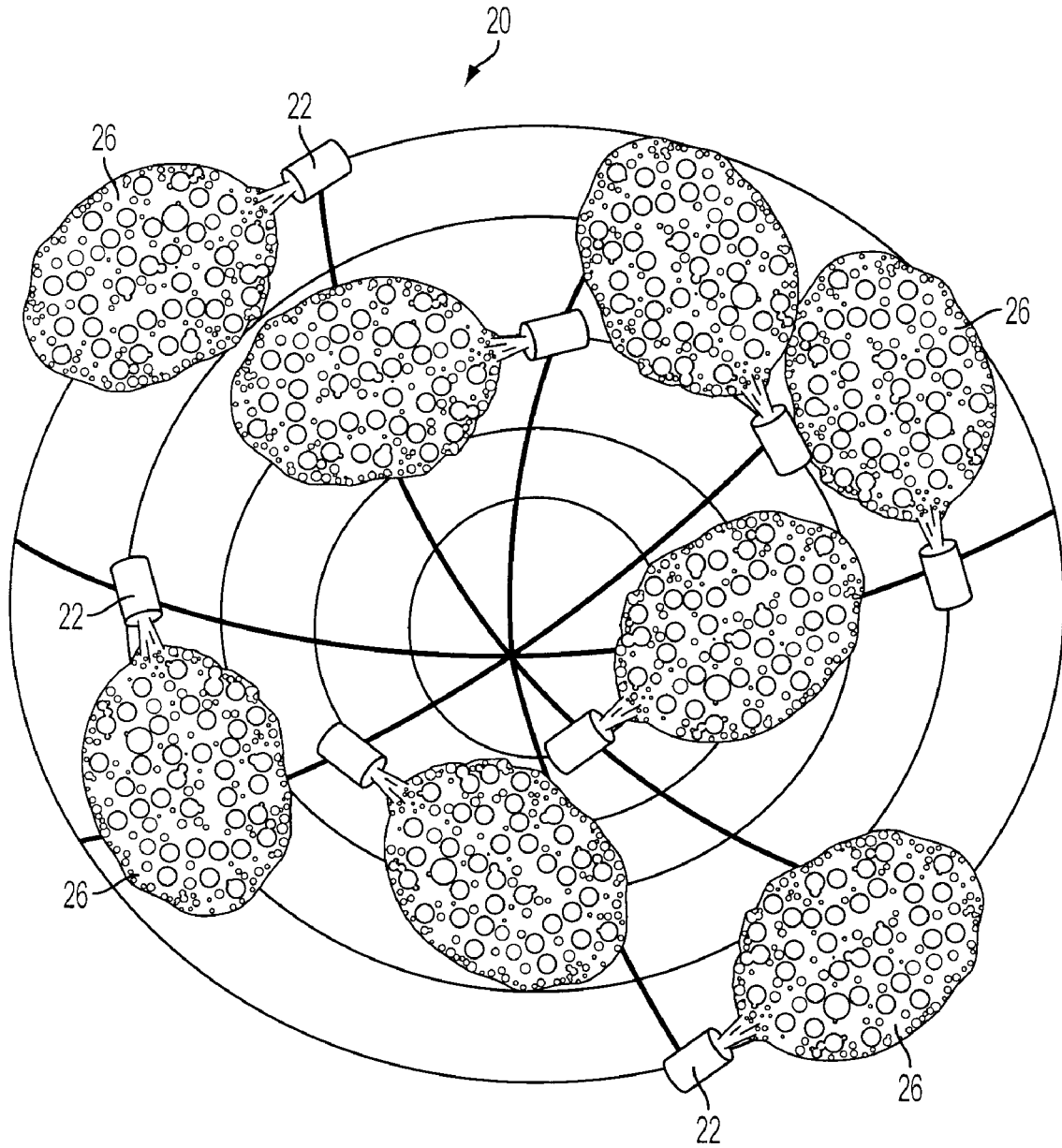

FIG. 7



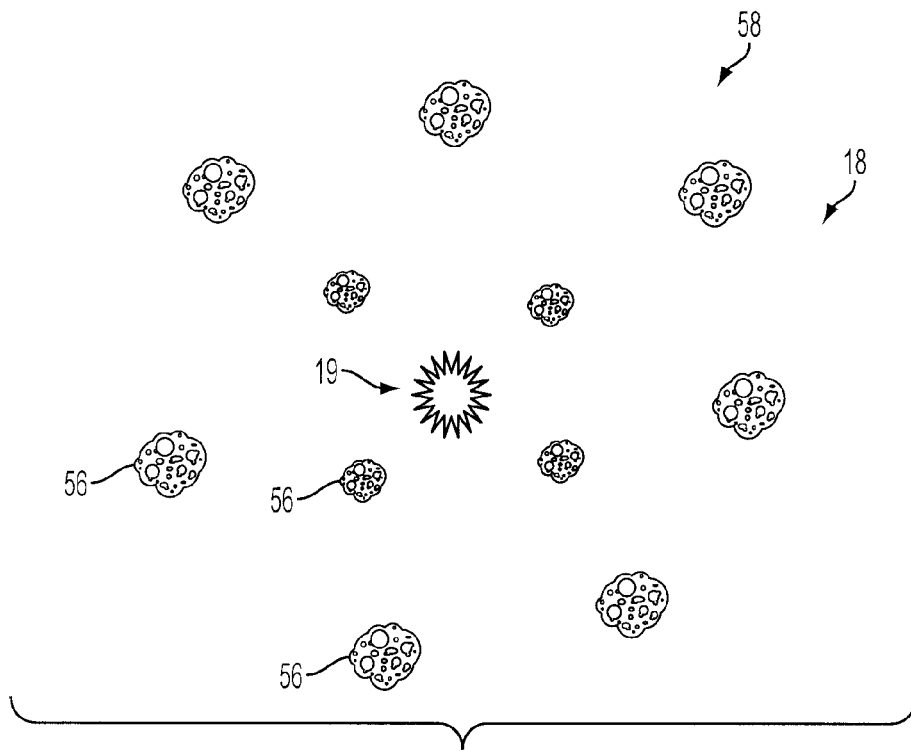

FIG. 8A

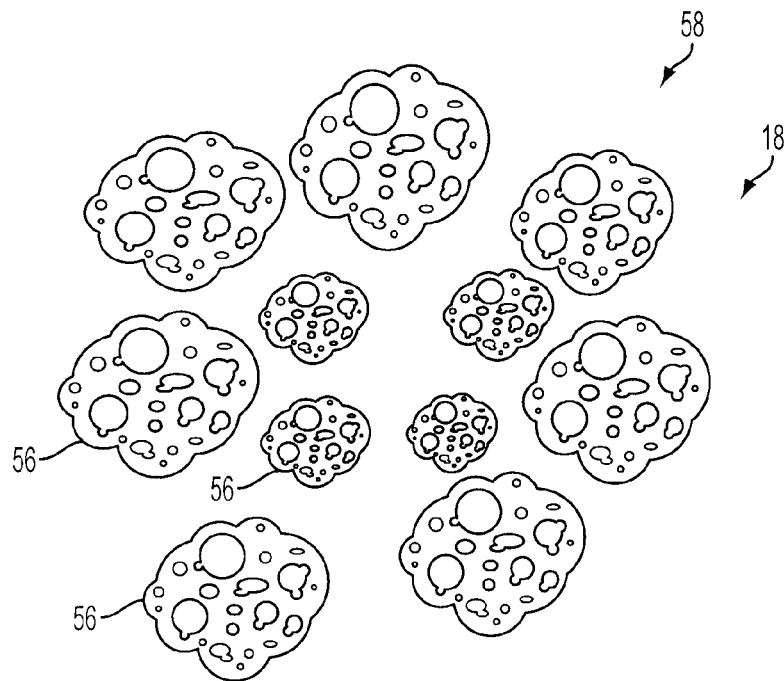

FIG. 8B

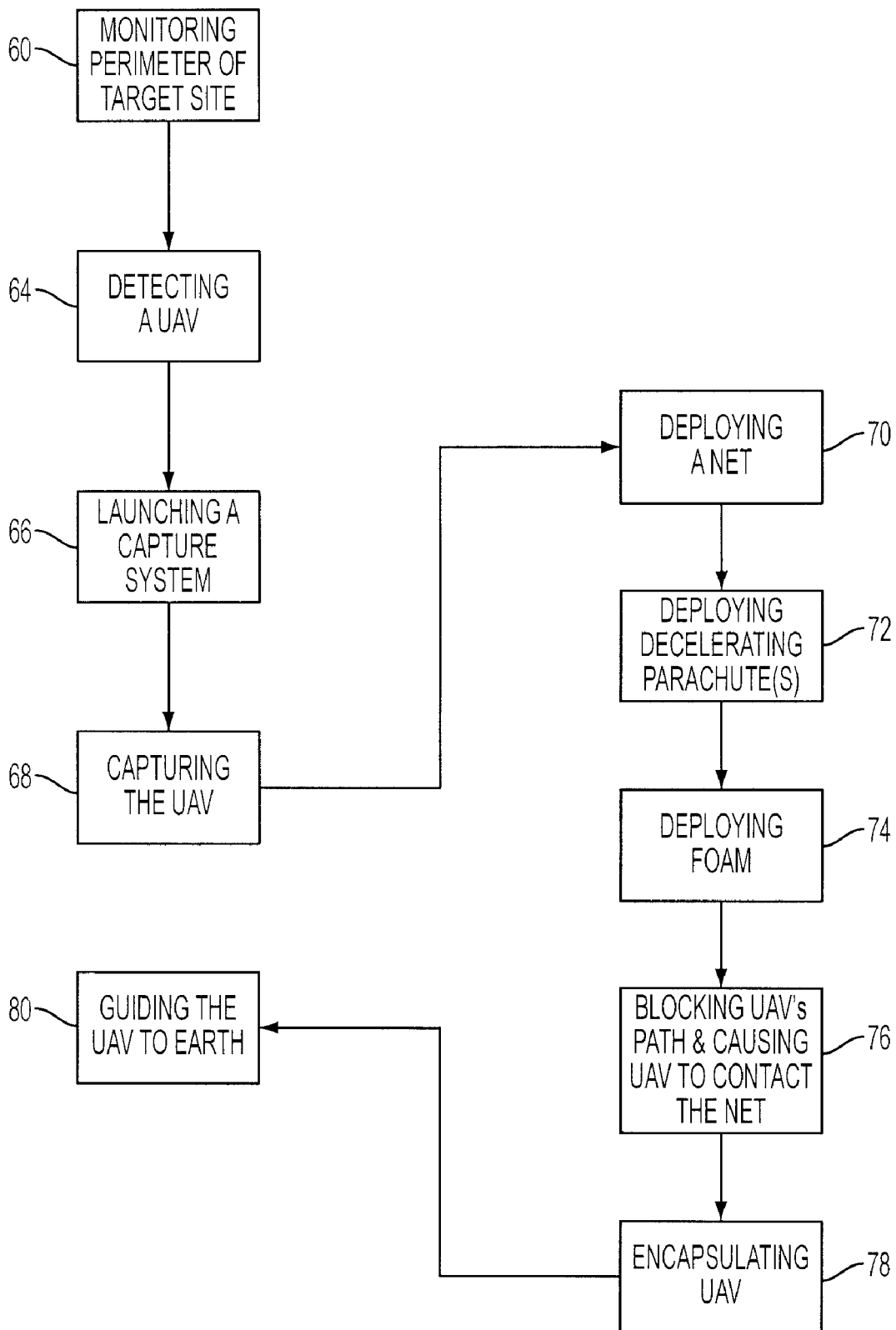

FIG. 9

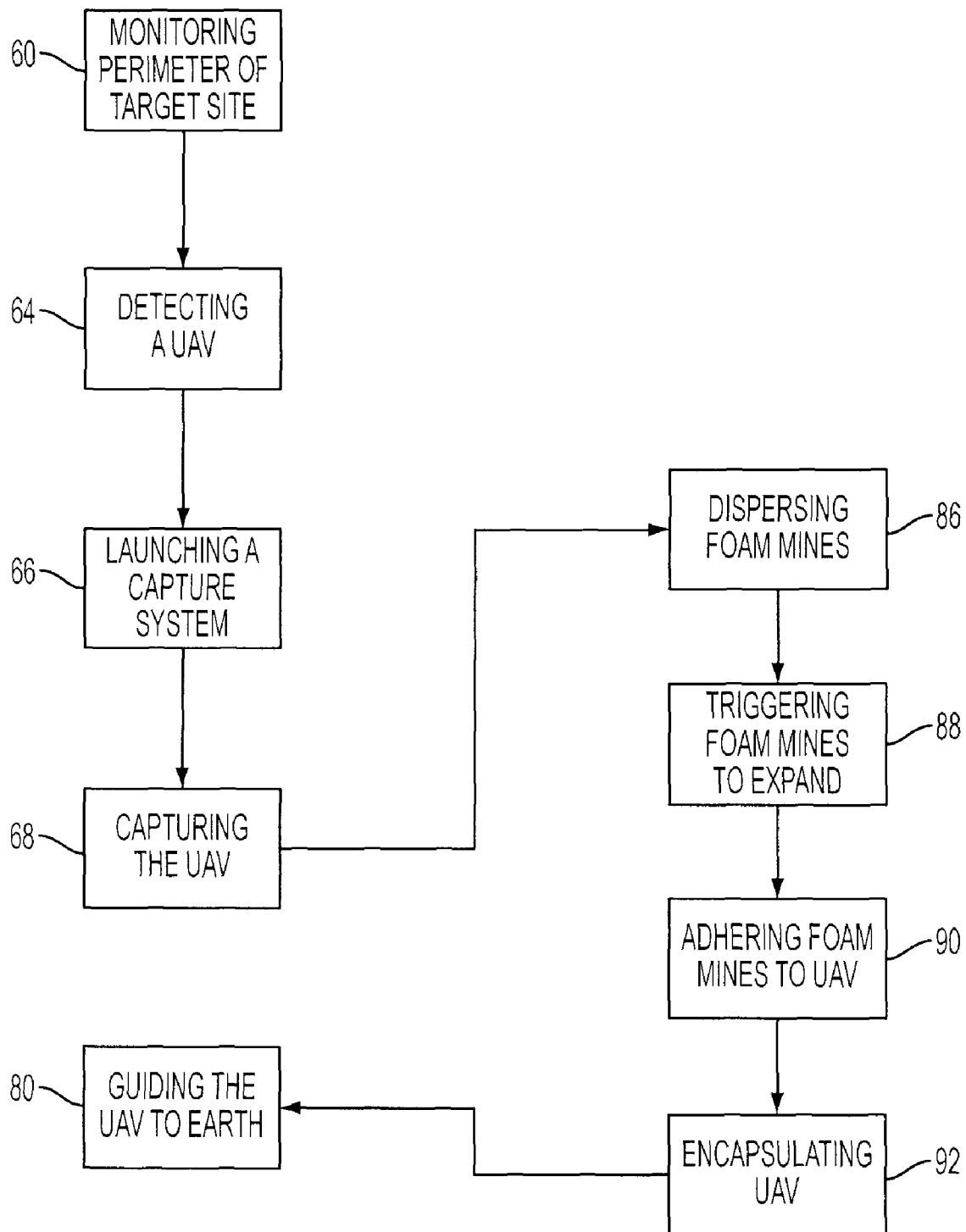

FIG. 10

1

## CATCH AND SNARE SYSTEM FOR AN UNMANNED AERIAL VEHICLE

### BACKGROUND OF THE INVENTION

There are systems in the art for intercepting intercontinental ballistic missiles, shoulder-launched rockets, and/or rocket propelled grenades. One example of an interception system operates by deploying a kill missile to destroy the incoming missile, which results in a debris field. Another example of an interception system involves launching a containment blanket made of Kevlar to contain the missile even if it detonates. Still further, an intercept device for flying objects exists that neither seriously damages nor destroys the flying object in question, but has a negative effect on its flying properties and then the intercept device destroys itself at a selected point in time so the flying object can return to its airfield unhindered and safely land.

However, with the advent of the low cost unmanned aerial vehicle, which can carry a significant payload of biological or chemical weapons, these previous interception systems are ineffective. Shooting down the UAV could trigger dispersal of the chemical or biological agent onboard. In addition, simply capturing the UAV in a net or containment blanket will not prevent the chemical or biological agent from leeching out into the atmosphere since these structures are not equipped to contain vapors and/or liquids. Moreover, merely diverting a UAV from its mission path does not constitute containing and isolating a biological or chemical threat. Thus, systems that can safely guide the UAV to earth, while at the same time preventing release of the biological or chemical threat until a hazmat team can isolate it, are generally desirable.

### SUMMARY OF THE INVENTION

The discovery presented herein details a catch and snare system for an unmanned aerial vehicle that has a beneficial effect of preventing the release of chemical or biological agents from the captured unmanned aerial vehicle into the environment.

Thus, in one aspect, the present invention provides a catch and snare system for an unmanned aerial vehicle comprising: (a) a detection system, (b) a deployment system in communication with the detection system, (c) a capture system placed at an interference position by the deployment system, wherein the capture system comprises a net, a plurality of foam deploying canisters attached to the net for deploying foam, and at least one canister for deploying a decelerating parachute attached to the net, wherein the foam prevents the release of chemical or biological agents from the captured unmanned aerial vehicle into the environment, and (d) a descent system to bring the capture system and a captured unmanned aerial vehicle back to earth.

In a second aspect, the present invention provides a catch and snare system for an unmanned aerial vehicle comprising: (a) a detection system, (b) a deployment system in communication with the detection system, (c) a capture system placed at an interference position by the deployment system, wherein the capture system comprises a plurality of foam mines that create an aerial minefield that is triggered to expand just before the unmanned aerial vehicle flies into the minefield to adhere to the unmanned aerial vehicle via surface contact with the foam while the plurality of foam mines continue to expand until at least a portion of the unmanned aerial vehicle is encapsulated in the expanded foam mines, wherein the foam prevents the release of chemical or biological agents from the captured unmanned aerial vehicle into the

2

environment, and (d) a descent system to bring the capture system and a captured unmanned aerial vehicle back to earth.

In a third aspect, the present invention provides a method for employing a catch and snare system for an unmanned aerial vehicle comprising: (a) monitoring the perimeter of a target site, (b) detecting an unmanned aerial vehicle within a predetermined distance of the perimeter, (c) launching a capture system, (d) capturing the unmanned aerial vehicle, wherein capturing the unmanned aerial vehicle comprises the steps of (i) deploying a net, (ii) deploying at least one decelerating parachute, (iii) deploying foam, (iv) blocking the unmanned aerial vehicle's flight path and causing the unmanned aerial vehicle to contact the net, and (v) encapsulating at least a portion of the unmanned aerial vehicle in the foam and the net, wherein the foam prevents the release of chemical or biological agents from the captured unmanned aerial vehicle into the environment, and (e) guiding the captured unmanned aerial vehicle to earth.

In a fourth aspect, the present invention provides a method for employing a catch and snare system for an unmanned aerial vehicle comprising: (a) monitoring the perimeter of a target site, (b) detecting an unmanned aerial vehicle within a predetermined distance of the perimeter, (c) launching a capture system, (d) capturing the unmanned aerial vehicle, wherein the step of capturing the unmanned aerial vehicle comprises the steps of (i) dispersing a plurality of foam mines to create an aerial minefield, (ii) triggering the plurality of foam mines to expand just before the unmanned aerial vehicle flies into the minefield, (iii) adhering the plurality of foam mines to the unmanned aerial vehicle via surface contact with the foam while the plurality of foam mines continue to expand, and (iv) encapsulating at least a portion of the unmanned aerial vehicle in the expanded foam mines, wherein the foam prevents the release of chemical or biological agents from the captured unmanned aerial vehicle into the environment, and (e) guiding the captured unmanned aerial vehicle to earth.

### BRIEF DESCRIPTION OF THE DRAWINGS

FIG. 1 is an elevated view of a catch and snare system in place around the perimeter of a target site.

FIG. 2 illustrates the detection system, deployment system, capture system, and descent system.

FIG. 3 illustrates one embodiment of the capture system.

FIG. 4 is a front view of one embodiment of the capture system's planar net and the spacing of the plurality of foam deploying canisters.

FIG. 5 is a side view of the capture system engaged around an unmanned aerial vehicle.

FIG. 6 is a front view of one embodiment of the capture system's planar net in a helical non-interference interleaving pattern.

FIG. 7 is a front view of one embodiment of the capture system's net engaged with an unmanned aerial vehicle and deploying sticky foam.

FIG. 8a is a view of one embodiment of the capture system's foam mines and mine field.

FIG. 8b is a view of one embodiment of the capture system's foam mines dispersing within the mine field.

FIG. 9 illustrates the steps to UAV capture from a ground launched capture system.

FIG. 10 illustrates the steps to UAV capture within a mined airspace.

### DETAILED DESCRIPTION OF THE PREFERRED EMBODIMENT

In one aspect, as shown in FIGS. 1-7, the present invention provides a catch and snare system 10 for an unmanned aerial

vehicle 12 comprising: (a) a detection system 14, (b) a deployment system 16 in communication with the detection system 14, (c) a capture system 18 placed at an interference position by the deployment system 16, wherein the capture system 18 comprises a net 20, a plurality of foam deploying canisters 22 attached to the net 20 for deploying foam, and at least one canister 24 for deploying a decelerating parachute 25 attached to the net 20, wherein the foam 26 prevents the release of chemical or biological agents from the captured unmanned aerial vehicle 28 into the environment, and (d) a descent system 30 to bring the capture system 18 and a captured unmanned aerial vehicle 28 back to earth.

As used herein, there are a variety of detection systems known in the art for detecting an unmanned aerial vehicle (UAV) 12. For example, the detection system 14 may identify the UAV 12, via radar, and a local or satellite-based communications network may transmit data to a command, control, and communications (CCC) base that indicates the UAV's location, velocity, and trajectory. The CCC base receives the data and determines a launch position and/or other trajectory characteristics necessary to intercept, contain, and retrieve the UAV 12.

As used herein, a deployment system 16 comprises a launcher configured to dispatch the capture system 18 to the interference position. The deployment system 16 may be based on land, air, or water. The air-based deployment system 16 may include, for example, a tethered balloon or manned or unmanned aerial vehicle that launches the capture system 18 from a guided missile or, alternatively, moves into position and drops the capture system 18 to the interference position. The CCC base and deployment system 16 may be positioned in separate locations or may be integrated systems in the same locale. The land- and water-based deployment systems 16 may comprise standard mortar launch systems. In addition, the air-, land-, and water-based deployment systems 16 may each be of another type known in the art. The deployment system 16 receives data from the CCC base that triggers deployment of the capture system 18 to the proper coordinates or interference position in order to intercept, contain, and retrieve the UAV 12.

As used herein, a capture system 18 comprises a launch capsule 19 into which is packaged a net 20, a plurality of foam deploying canisters 22 attached to the net 20, and at least one canister 24 for deploying a decelerating parachute 25 attached to the net 20. The net 20 is made of a lightweight, low volume, high strength fiber, preferably Spectra® fiber. The impact between the UAV 12 and the net 20 should generally be negligible so as not to trigger premature release of the biological or chemical weapon. Depending on the kinetic energies of the UAV 12 and the net assembly, the net 20 may not slow the UAV 12 to a stop necessitating the use of parachutes to further slow the combined assembly. The at least one decelerating parachute 25 may deploy prior to or after the UAV 12 contacts the net 20. If the at least one decelerating parachute 25 is deployed prior to the UAV 12 contacting the net 20, then the decelerating parachute 25 may assist the net 20 with hovering in mid-air. Once the UAV 12 contacts the net 20, the net 20 wraps around the UAV 12 such that the edges of the net 20 essentially join at or near the rear of the UAV 12, properly aligning the plurality of foam deploying canisters 22 along the length of the UAV 12. The typical UAV 12 weighs between 1 to 50 kilograms and is traveling between 30 to 120 knots. The at least one decelerating parachute 25 alone, or in combination with additional decelerating parachutes 25, is capable of rapidly bringing this typical UAV 12 to a halt. Since the velocity of the UAV 12 is greatly slowed, the wind velocity will be substantially lower during foam deployment.

As shown in FIG. 7, after the UAV 12 is slowed, the foam 26 is triggered to deploy from the canisters 22. The triggering mechanism is of a type known in the art, for example, an accelerometer, a timer, a manual deployment signal from the CCC base, or any other technique known in the art. As the UAV 12 is slowed by the net and below the velocity needed to maintain a foam bubble, the sticky foam 26 is released to begin encapsulation substantially before the orientation of the UAV 12 is altered so as to avoid triggering of any bio release mechanisms. The net 20 will essentially wrap the foam deploying canisters 22 into proper orientation around the UAV 12 while minimizing inertial impact to the UAV 12. This will minimize the risk of inertially triggered bio-release mechanisms on the UAV 12. Alternatively, the foam 26 may deploy just before the UAV 12 contacts the net 20 such that the sticky foam 26 and the net 20 substantially encapsulate the UAV 12 upon impact.

As used herein, the plurality of foam deploying canisters 22 are made of a lightweight material, preferably carbon fiber. Each of the plurality of foam deploying canisters 22 contains one or more jets that direct the path of the foam 26. The foam deploying canisters 22 are oriented in a cooperative direction so that the foam paths merge and join completely to encapsulate at least a portion of the UAV 12, namely the portion containing the hazardous payload. The foam deploying canister 22 may be constructed using systems known in the art. For instance, the foam deploying canister 22 may comprise a pressurized gas supply, a gas valve, a gas conduit, a vessel containing sticky foam, a burst valve, a solution conduit, and a delivery orifice. The pressurizing gas is inactive until the gas valve is actuated, and the gas flows through the gas conduit into the vessel until the pressure within the vessel reaches a predetermined value and the burst valve ruptures directing the contents of the vessel to flow through the solution conduit to the delivery orifice and then into the surrounding environment. The combined plurality of foam deploying canisters 22 would have to deploy approximately five hundred cubic feet of expanded foam 26 to substantially encapsulate an entire UAV 12 weighing 50 kg. Lighter than air propellants may be used to assist in keeping the foam bubble aloft and to reduce the sink rate.

As used herein, the foam 26 remains stable sufficiently long enough for hazmat neutralization of any potential chemical or biological agents. The closed cell structure of the foam 26 captures or contains any vapors to the extent that vapors do not degrade the foam 26. The thickness of the foam covering 26 can vary according to the anticipated biological or chemical agent payload on the UAV 12 and is controlled by the pressure under which the foam 26 is released. Preferably the foam 26 is a ninety percent closed cell structure that is substantially four inches thick. The preferred cure time is very rapid, approximately thirty seconds, though longer cure times are contemplated depending on the type of threat. Examples of the type of foam 26 contemplated include sticky foam disclosed in U.S. Pat. No. 4,202,279 and stabilized aqueous foam systems and concentrate disclosed in U.S. Pat. No. 4,442,018. The disclosures of U.S. Pat. Nos. 4,202,279 and 4,442,018 are incorporated by reference herein.

As used herein, a descent system 30 comprises at least one canister 32 attached to the net 20 that deploys at least one descent parachute 34 to guide the captured UAV 28 to the ground. The at least one descent parachute 34 must be capable of withstanding the dynamic forces of the descending UAV 28, the plurality of foam deploying canisters 22, as well as the deployed foam 26. In one embodiment, the descent parachute 34 may be the same as the at least one decelerating parachute 25. For example, after the UAV 12 decelerates sufficiently due

5

to the decelerating parachute **25**, the UAV **12, 28** will begin to fall towards the ground at which time the decelerating parachute **25** will be substantially vertical relative to the ground and acting as a descent parachute **34**. Alternatively, a separate descent parachute **34** may be deployed from a canister **32** attached to the net **20** near the net's edge and therefore near the rear of the UAV **12, 28**. This separate descent parachute **34** preferably deploys at approximately the same time the foam **26** begins to deploy from the canisters **22**. Further, this separate descent parachute **34** is preferably attached to the net **20** by one or more lines (not shown) that extend the suspension lines **36** and the parachute's canopy **38** beyond the reach of the foam **26**.

In one embodiment, the foam has an expansion ratio that is at least 20:1. The preferred foam expansion ratio is in the range of 20:1 to 200:1, although higher expansion ratios are contemplated.

In one embodiment, as shown in FIGS. 3-4 and 6, the net **20** is substantially planar upon deployment. The planar net **20** may comprise any number of shapes, for example, the net may be square, circular, or hexagonal. As used herein, substantially planar means that the net **20** is unfolded or unpackaged from the launch capsule **19** and the net edges **44** are essentially fully extended. The net **20** is considered to be substantially planar even in the event that a wind gust causes some slight bending or billowing in the net **20**, as shown in FIG. 3.

In one embodiment, the plurality of foam deploying canisters **22** are arranged along at least two lines **46** that cross at the center of the net **20**, as shown in FIGS. 3-4. In this embodiment the net **20** is grid-like or comprises polygons or diamonds joined at their corners in a repeating pattern, for example. In an embodiment where there are only two lines **46**, these lines **46** are preferably substantially perpendicular to one another and, in the case of a square net **20**, each line **46** preferably extends diagonally from corner to corner in an "X" configuration **48**, as shown in FIGS. 4-5. This "X" configuration **48** provides foam coverage to four sides of the UAV **12**. Where there are more than two lines **46** present, the lines **46** are preferably spaced so as to be substantially equidistant from each other to ensure even deployment of foam **26**.

In one embodiment, the capture system **18** further comprises at least one canister **50** attached to the net **20** for deploying at least one hover parachute **52**, and wherein the descent system **30** comprises at least one canister **32** attached to the net **20** for deploying at least one descent parachute **34**. As used herein, employing a hover parachute **52** allows the net **20** to be launched further in advance of the approach of the UAV **12** and still remain at the proper interference position. The at least one hover parachute **52** may comprise the at least one decelerating parachute **25** such that the decelerating parachute **25** is deployed essentially at the time the net **20** has unfolded from the launch capsule **19** or shortly thereafter. Alternatively, the at least one hover parachute **52** may be smaller and weigh less than the at least one decelerating parachute **25** and the at least one hover parachute **52** may have shorter suspension lines **36** such that a portion of the at least one hover parachute **52** may be subsumed by the foam **26**.

As used herein, the at least one descent parachute **34** may comprise the hover parachute **52** and/or the decelerating parachute **25** or may comprise a separate parachute altogether. The descent parachute **34** may be deployed at any time after the net **20** is unfolded as long as the canopy **38** and suspension lines **36** are long enough to extend beyond the deployed foam's reach **26**. Alternatively, the descent parachute **34** is deployed after the UAV's forward velocity has halted.

6

In one embodiment, as shown in FIG. 6, the net **20** is designed in a helical non-interference interleaving pattern and the plurality of foam deploying canisters **22** are spaced along the main lines **54** extending from the center of the net **20** to the net edges. The plurality of foam deploying canisters **22** are spaced apart to maximize foam deployment over the UAV's surface, while minimizing canister interference when stored. The foam deploying canisters **22** are spaced and sized according to the required volume each must supply. For example, where the canisters **22** are equidistantly spaced, the canister volume is largest at the net's edges and gradually decreases the closer they are placed to the center of the net's interleaving spiral.

In one embodiment, the capture system **18** further comprises at least one canister **50** attached to the net **20** for deploying at least one hover parachute **52**, and wherein the descent system **30** comprises at least one canister **32** attached to the net **20** for deploying at least one descent parachute **34**. As used herein, employing a hover parachute **52** allows the net **20** to be launched further in advance of the approach of the UAV **12** and still remain at the proper interference position. The at least one hover parachute **52** may comprise the at least one decelerating parachute **25** such that the decelerating parachute **25** is deployed essentially at the time the net **20** has unfolded from the launch capsule **19** or shortly thereafter. Alternatively, the at least one hover parachute **52** may be smaller and weigh less than the at least one decelerating parachute **25** and the at least one hover parachute **52** may have shorter suspension lines **36** such that a portion of the at least one hover parachute **52** is subsumed by the foam **26**.

As used herein, all the foregoing descriptions and embodiments with respect to the first aspect are equally applicable to the following aspects as well. Furthermore, all embodiments disclosed for each aspect may be combined with other embodiments.

In a second aspect, as shown in FIGS. 1 and 8a-8b, the present invention provides a catch and snare system **10** for a UAV **12** comprising: (a) a detection system **14**, (b) a deployment system **16** in communication with the detection system **14**, (c) a capture system **18** placed at an interference position by the deployment system **16**, wherein the capture system **18** comprises a plurality of foam mines **56** that create an aerial minefield **58** that is triggered to expand just before the UAV **12** flies into the minefield **58** to adhere to the UAV **12** via surface contact with the foam **26** while the plurality of foam mines **56** continue to expand until at least a portion of the UAV **28** is encapsulated in the expanded foam mines **56**, wherein the foam **26** prevents the release of chemical or biological agents from the captured UAV **28** into the environment, and (d) a descent system **30** to bring the capture system **18** and a captured UAV **12** back to earth.

As used herein, the capture system **18** comprises one or more launch capsules **19** into which are packaged a plurality of foam mines **56**. Upon release from the launch capsule **19**, the foam mines **56** are scattered across the projected path of the UAV **12** in a pattern based on the capture area that each foam mine **56** is capable of achieving. Due to the kinetic energy of the UAV **12**, the UAV **12** will substantially embed within the sticky foam **26**, which absorbs energy while slowing the UAV's velocity. The foam mines **56** begin deploying foam **26** after release from the launch capsule **19** and are triggered either by an accelerometer, a timer, a manual signal from the CCC base, or any other technique known in the art. Lighter-than-air foaming gasses, such as helium, may be employed to help keep the foam aloft long enough to make contact with the UAV **12**. As the UAV **12** flies through the minefield **58** the sticky foam **26** adheres the mines **56** to the

surface of the UAV 12, 28. The impact between the UAV 28 and the foam mines 56 should generally be negligible so as not to trigger premature release of the biological or chemical weapon. The first foam mine 56 to contact and adhere to the UAV 12 will provide drag slowing the whole mass. As the mass slows, sticky foam 26 simultaneously encapsulates the UAV 12 preventing release of biological or chemical weapons.

In one embodiment, the descent system 30 comprises a canister 32 for deploying a descent parachute 34 attached to each foam mine 56. Each foam mine 56 that adheres to the UAV 12 will contain a descent parachute 34. The trigger for the descent parachute canister 32 may be an accelerometer, a timer, a manual signal from the CCC base, or any other technique known in the art.

In a third aspect, as shown in FIG. 9, the present invention provides a method for employing a catch and snare system 10 for an unmanned aerial vehicle 12 comprising: (a) monitoring 60 the perimeter 62 of a target site, (b) detecting 64 a UAV 12 within a predetermined distance of the perimeter 62, (c) launching 66 a capture system 18, (d) capturing 68 the UAV 28, wherein capturing the UAV 12, 28 comprises the steps of (i) deploying 70 a net 20, (ii) deploying 72 at least one decelerating parachute 25, (iii) deploying 74 foam 26, (iv) blocking 76 the UAV's flight path and causing the UAV 12 to contact the net 20, and (v) encapsulating 78 at least a portion of the UAV 28 in the foam 26 and the net 20, wherein the foam 26 prevents the release of chemical or biological agents from the captured UAV 28 into the environment, and (e) guiding 80 the captured UAV 28 to earth.

As used herein, deployment 72, 74 of the foam 26 and parachutes 25, 34, 52 from the various canisters 22, 24, 32, 50 is achieved using a trigger device such as an accelerometer, a timer, a manual signal from the CCC base, or any other technique known in the art. For example, in the foam deploying canister 22, the trigger device may activate the gas valve, or any other mechanism, that is intended to activate the canister 22. Similarly, the trigger device can activate a canister 24, 32, 50 for deploying a parachute 25, 34, 52 by causing a detonation via an explosive device or by release of fasteners holding portions of the canister 24, 32, 50 together.

In one embodiment, capturing 68 the UAV 12 further comprises the step of hovering 82 via the at least one decelerating parachute 25 prior to encapsulating 78 at least a portion of the UAV 28 in the foam 26 and the net 20.

In one embodiment, guiding 80 the UAV 28 comprises the step of deploying 84 at least one descent parachute 34.

In one embodiment, the net 20 is made of a lightweight, high strength fiber.

In one embodiment, the net 20 is made of spectra fiber.

In one embodiment, the net 20 is substantially planar upon deployment.

In a fourth aspect, as shown in FIG. 10, the present invention provides a method for employing a catch and snare system 10 for an UAV 12 comprising: (a) monitoring 60 the perimeter 62 of a target site, (b) detecting 64 a UAV 12 within a predetermined distance of the perimeter 62, (c) launching 66 a capture system 18, (d) capturing 68 the UAV 12, wherein the step of capturing 68 the UAV 12 comprises the steps of (i) dispersing 86 a plurality of foam mines 56 to create an aerial minefield 58, (ii) triggering 88 the plurality of foam mines 56 to expand just before the UAV 12 flies into the minefield 58, (iii) adhering 90 the plurality of foam mines 56 to the UAV 28 via surface contact with the foam 26 while the plurality of foam mines 56 continue to expand, and (iv) encapsulating 92 at least a portion of the UAV 28 in the expanded foam mines 56, wherein the foam 26 prevents the release of chemical or

biological agents from the captured UAV 28 into the environment, and (e) guiding 80 the captured UAV 28 to earth.

In one embodiment, the plurality of foam mines 56 are dispersed from an airborne vehicle. The airborne vehicle may comprise a tethered balloon, a manned aerial vehicle, an unmanned aerial vehicle, or any other type of aerial vehicle known in the art. The airborne vehicle may physically move to a drop point and release the plurality of foam mines 56 or alternatively may launch a guided missile, which ejects the foam mines 56 above the interference position.

In one embodiment, the plurality of foam mines 56 are dispersed from a ground missile. The ground missile may launch from either a land- or water-based location and then release the plurality of foam mines 56 at the interference position.

The invention claimed is:

1. A catch and snare system for an unmanned aerial vehicle, the catch and snare system comprising:

a detection system configured to detect an unmanned aerial vehicle;

a deployment system in communication with the detection system;

a capture system configured to be placed at an interference position by the deployment system, wherein the capture system comprises a net configured to capture the unmanned aerial vehicle, a plurality of foam deploying canisters attached to the net and configured to deploy foam, and at least one canister configured to deploy at least one decelerating parachute attached to the net, wherein the foam is configured to prevent the release of chemical or biological agents from the unmanned aerial vehicle into the environment; and

a descent system configured to bring the capture system and the unmanned aerial vehicle back to earth.

2. The catch and snare system of claim 1, wherein the foam has an expansion ratio that is at least 20:1.

3. The catch and snare system of claim 2, wherein the net is substantially planar upon deployment.

4. The catch and snare system of claim 1, wherein the plurality of foam deploying canisters are arranged along at least two lines that cross at the center of the net.

5. The catch and snare system of claim 1, wherein the capture system further comprises at least one canister attached to the net for deploying at least one hover parachute, and wherein the descent system comprises at least one canister attached to the net for deploying at least one descent parachute.

6. The catch and snare system of claim 1, wherein the net is designed in a helical non-interference interleaving pattern and the plurality of foam deploying canisters are spaced along the main lines extending from the center of the net to the net edges.

7. The catch and snare system of claim 6, wherein the capture system further comprises at least one canister attached to the net for deploying at least one hover parachute, and wherein the descent system comprises at least one canister attached to the net for deploying at least one descent parachute.

8. The catch and snare system of claim 1, wherein the net is made of a lightweight, high strength fiber.

9. The catch and snare system of claim 1, wherein the detection system is configured to transmit data to a command, control, and communications base that indicates a location, velocity, and trajectory of the unmanned aerial vehicle.

10. The catch and snare system of claim 1, wherein the deployment system comprises a tethered balloon or an aerial

9

vehicle that is configured to launch the capture system to the interference position or drop the capture system to the interference position.

11. The catch and snare system of claim 10, wherein the aerial vehicle is configured to launch the capture system from a guided missile. 5

12. The catch and snare system of claim 1, wherein the capture system comprises a launch capsule comprising the net.

13. The catch and snare system of claim 1, wherein the net is configured to wrap around the unmanned aerial vehicle to capture the unmanned aerial vehicle. 10

14. The catch and snare system of claim 1, wherein each foam deploying canister of the plurality of foam deploying canisters is configured to generate a foam path, and wherein the plurality of foam deploying canisters are oriented in a cooperative direction so that foam paths merge and join completely to encapsulate at least a portion of the unmanned aerial vehicle. 15

15. A method for employing a catch and snare system for an unmanned aerial vehicle, the method comprising: 20

monitoring a perimeter of a target site;

with a detection system, detecting an unmanned aerial vehicle within a predetermined distance of the perimeter;

upon detecting the unmanned aerial vehicle, placing the capture system at an interference position with a deployment system in communication with the detection system;

capturing the unmanned aerial vehicle with the capture system, wherein the capture system comprises a net configured to capture the unmanned aerial vehicle, a plurality of foam deploying canisters attached to the net and configured to deploy foam, and at least one canister configured to deploy at least one decelerating parachute attached to the net, wherein the foam is configured to prevent the release of chemical or biological agents from 25 30 35

10

the unmanned aerial vehicle into the environment, and wherein capturing the unmanned aerial vehicle with the capture system comprises:

deploying the net to block a flight path of the unmanned aerial vehicle and cause the unmanned aerial vehicle to contact the net;

with the at least one canister, deploying the at least one decelerating parachute attached to the net;

with a plurality of foam deploying canisters attached to the net, deploying foam; and encapsulating at least a portion of the unmanned aerial vehicle in the foam and the net; and

with a descent system, guiding the capture system and the captured unmanned aerial vehicle to earth.

16. The method of claim 15, wherein capturing the unmanned aerial vehicle further comprises hovering the net in mid-air, via the at least one decelerating parachute, prior to encapsulating at least a portion of the unmanned aerial vehicle in the foam and the net.

17. The method of claim 16, wherein the descent system comprises at least one descent parachute and guiding the capture system and the captured unmanned aerial vehicle to earth comprises deploying the at least one descent parachute.

18. The method of claim 15, wherein the plurality of foam deploying canisters are arranged along at least two lines that cross at a center of the net. 25

19. The method of claim 15, wherein the net is designed in a helical non-interference interleaving pattern and the plurality of foam deploying canisters are spaced along the main lines extending from a center of the net to edges of the net.

20. The method of claim 15, wherein placing the capture system at an interference position with the deployment system comprises launching a capsule comprising the net, the plurality of foam deploying canisters, and at least one canister configured to deploy the at least one decelerating parachute. 30 35

\* \* \* \* \*